



Appendix I

Integrated Transport Assessment

Part 2 of 3

Appendix 6: SIDRA Modelling Outputs

SIDRA Network and Intersection Outputs

2048 10B Mitigated AM

NETWORK LAYOUT

Network: N101 [2048_Opt10B_AM (Network Folder: General)]

New Network
 Network Category: (None)

Layout pictures are schematic functional drawings reflecting input data. They are not design drawings.

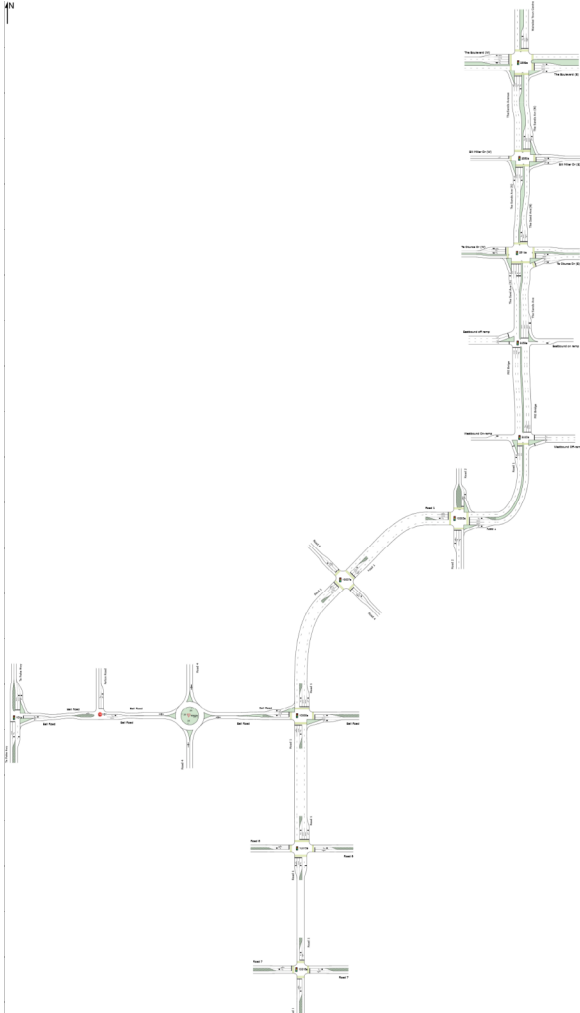

SITES IN NETWORK		
Site ID	CCG ID	Site Name
2859a	NA	2859 Boulv_TheSand_AM
2860a	NA	2860 The Sand_Bill Miller_AM
2514a	NA	2514 Sands_Te Okuroa_AM
2439a	CCG1	2439 Papamoa Eastern Int North_AM
2440a	CCG1	2440 Papamoa Eastern Int South_AM
10003a	NA	10003_AM
10007a	NA	10007_AM
10008a	NA	10008_AM
10015a	NA	10015_AM
10016a	NA	10016_AM
10013a	NA	10013_AM
101	NA	1348 Bell Rd Parton Rd AM
101v	NA	2140 Te Puke Hwy Bell Rd AM Signals

APPROACH LEVEL OF SERVICE

Approach Level of Service

Network: N101 [2048_Opt10B_AM (Network Folder: General)]

Output produced by SIDRA INTERSECTION Version: 9.1.6.228

New Network

Network Category: (None)

Network Cycle Time = 130 seconds (Network Optimum Cycle Time - Minimum Delay)

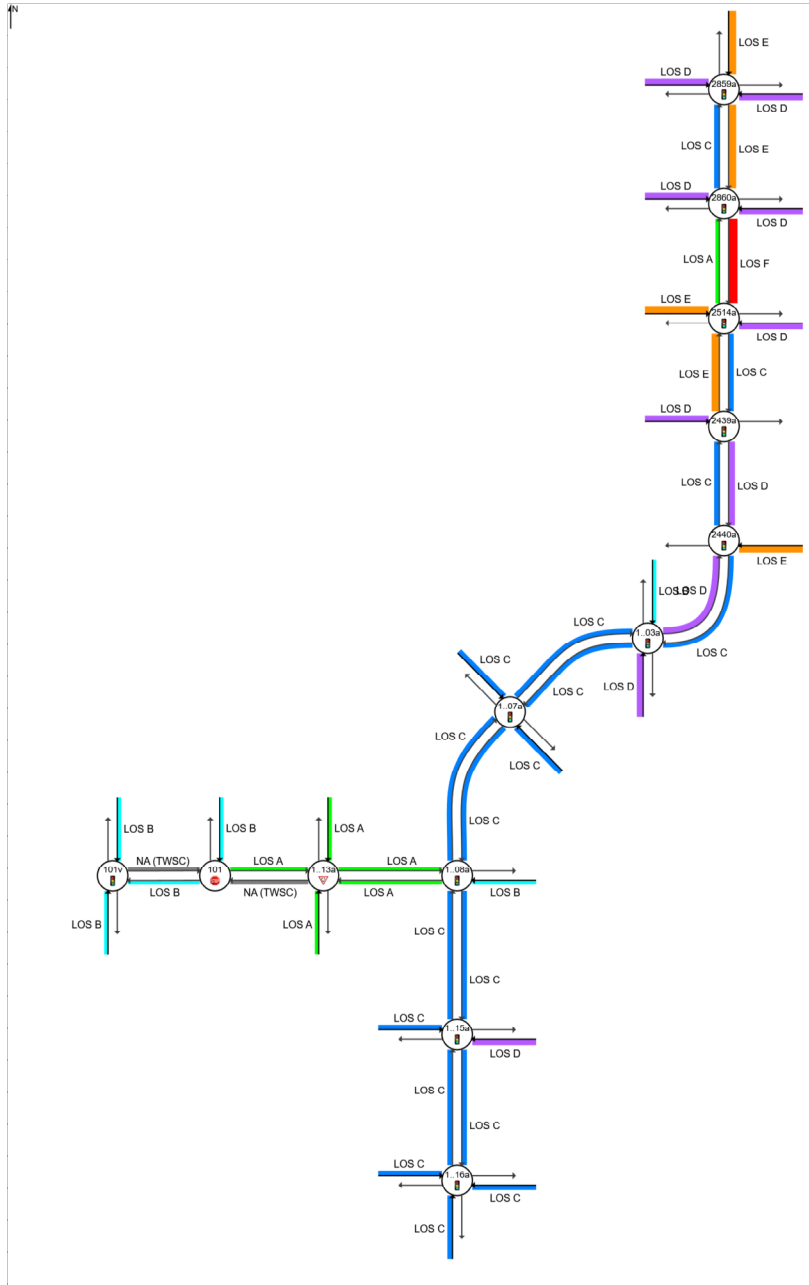

Colour code based on Level of Service



NA (TWSC): Level of Service is not defined for major road approaches or the intersection as a whole for Two-Way Sign Control (HCM LOS rule).

Site Level of Service (LOS) Method: Delay (SIDRA). Site LOS Method is specified in the Network Data dialog (Override Site Data tab).

Delay Model: SIDRA Standard (Control Delay: Geometric Delay is included).

DEGREE OF SATURATION

Ratio of Arrival Flow to Capacity, v/c ratio per lane

Network: N101 [2048_Opt10B_AM (Network Folder: General)]

Output produced by SIDRA INTERSECTION Version: 9.1.6.228

New Network

Network Category: (None)

Network Cycle Time = 130 seconds (Network Optimum Cycle Time - Minimum Delay)

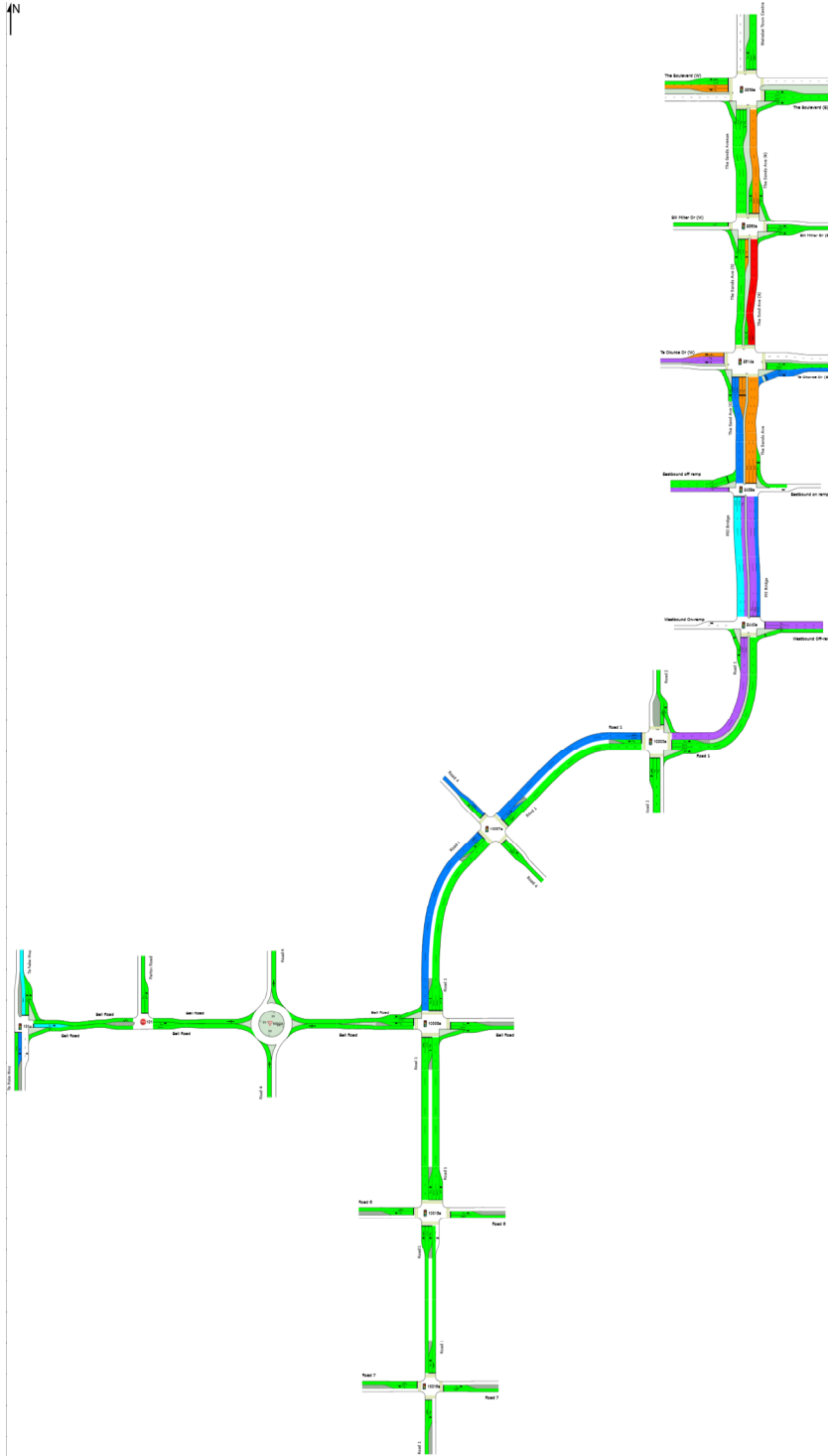

Colour code based on Degree of Saturation

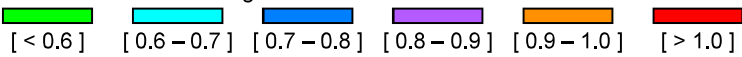

QUEUE STORAGE RATIO (PERCENTILE)

Ratio of the 95% Back of Queue Distance to the available queue storage distance per lane

Network: N101 [2048_Opt10B_AM (Network Folder: General)]

Output produced by SIDRA INTERSECTION Version: 9.1.6.228

New Network

Network Category: (None)

Network Cycle Time = 130 seconds (Network Optimum Cycle Time - Minimum Delay)

Short Lanes are not included in determining Queue Storage Ratios.

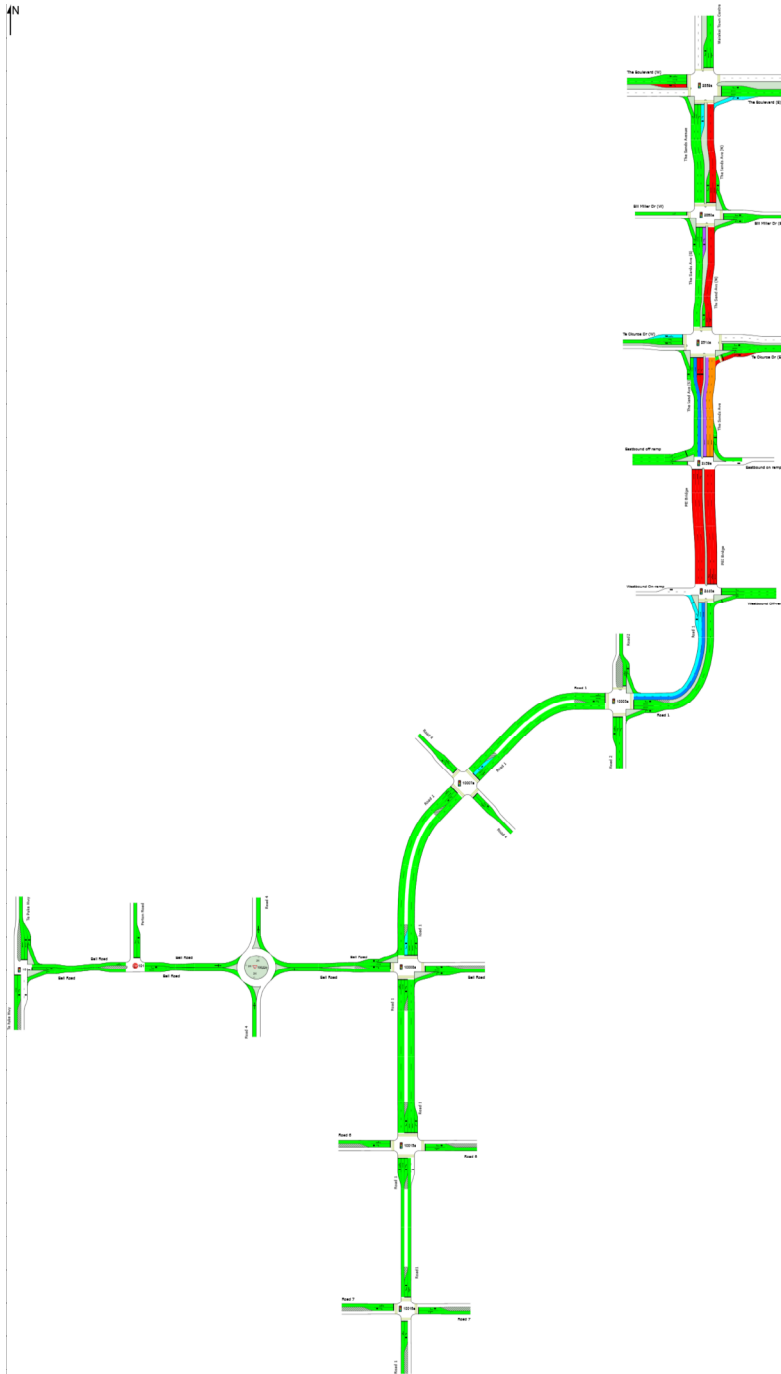

Colour code based on Queue Storage Ratio

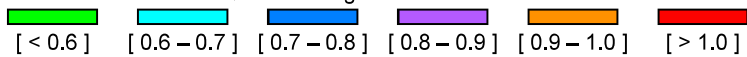

Queue Model: SIDRA queue estimation methods are used for Back of Queue and Queue at Start of Green.

CCG MOVEMENT SUMMARY

Common Control Group: CCG1 [CCG_1]

Output produced by SIDRA INTERSECTION Version: 9.1.6.228

Network: N101
[2048_Opt10B_AM (Network Folder: General)]

EQUISAT (Fixed-Time/SCATS) Coordinated Cycle Time = 130 seconds (Network Optimum Cycle Time - Minimum Delay)

Vehicle Movement Performance (CCG)															
Mov ID	Turn	Mov Class	Demand Flows		Arrival Flows		Deg. Satn	Aver. Delay	Level of Service	Aver. Back Of Queue		Prop. Que	Eff. Stop Rate	Aver. No. of Cycles	Aver. Speed
			[Total HV]	%	[Total HV]	%				[Veh. veh	Dist]				
Site: 2439a [2439 Papamoa Eastern Int North_AM]															
South: PEI Bridge															
2	T1	All MCs	1093	11.2	1093	11.2	0.658	12.7	LOS B	10.7	82.4	0.55	0.49	0.55	21.1
3	R2	All MCs	303	11.2	303	11.2	0.872	73.3	LOS E	12.8	97.8	1.00	0.97	1.17	19.1
Approach			1396	11.2	1396	11.2	0.872	25.8	LOS C	12.8	97.8	0.65	0.60	0.68	19.9
North: The Sands Ave															
7	L2	All MCs	908	11.2	903	11.2	0.520	4.7	LOS A	0.0	0.0	0.00	0.46	0.00	45.1
8	T1	All MCs	1369	11.2	1362	11.2	*0.905	41.9	LOS D	19.7	151.4	0.92	0.99	1.11	15.6
Approach			2278	11.2	2265	11.2	0.905	27.1	LOS C	19.7	151.4	0.55	0.78	0.67	27.5
West: Eastbound off ramp															
10	L2	All MCs	744	11.2	744	11.2	0.473	30.9	LOS C	10.0	76.6	0.75	0.78	0.75	27.5
12	R2	All MCs	86	11.2	86	11.2	0.861	81.8	LOS F	3.9	30.3	1.00	1.02	1.41	15.7
Approach			831	11.2	831	11.2	0.861	36.2	LOS D	10.0	76.6	0.77	0.80	0.81	25.5
All Vehicles			4504	11.2	4492	11.2	0.905	28.4	LOS C	19.7	151.4	0.62	0.73	0.70	25.3
Site: 2440a [2440 Papamoa Eastern Int South_AM]															
South: Road 1															
1	L2	All MCs	269	11.4	269	11.4	0.255	18.5	LOS B	4.7	35.9	0.49	0.67	0.49	38.8
2	T1	All MCs	934	11.4	934	11.4	*0.876	53.8	LOS D	20.4	156.8	1.00	1.02	1.16	16.5
Approach			1203	11.4	1203	11.4	0.876	45.9	LOS D	20.4	156.8	0.89	0.94	1.01	21.3
East: Westbound Off-ramp															
4	L2	All MCs	151	11.4	151	11.4	0.193	27.1	LOS C	3.4	26.5	0.63	0.71	0.63	29.1
6	R2	All MCs	456	11.4	456	11.4	0.831	66.6	LOS E	10.5	80.7	1.00	0.95	1.19	17.9
Approach			606	11.4	606	11.4	0.831	56.8	LOS E	10.5	80.7	0.91	0.89	1.05	19.9
North: PEI Bridge															
8	T1	All MCs	624	11.4	620	11.4	0.753	19.3	LOS B	15.0	115.0	0.75	0.67	0.75	16.2
9	R2	All MCs	838	11.4	833	11.4	0.829	50.4	LOS D	15.0	115.0	0.97	0.90	1.04	23.4
Approach			1462	11.4	1453	11.4	0.829	37.1	LOS D	15.0	115.0	0.87	0.81	0.92	22.1
All Vehicles			3272	11.4	3263	11.4	0.876	44.0	LOS D	20.4	156.8	0.88	0.87	0.97	21.3

Site Level of Service (LOS) Method: Delay (SIDRA). Site LOS Method is specified in the Network Data dialog (Override Site Data tab).

Vehicle movement LOS values are based on average delay per movement.

Intersection and Approach LOS values are based on average delay for all vehicle movements.

Delay Model: SIDRA Standard (Control Delay: Geometric Delay is included).

Gap-Acceptance Capacity Formula: SIDRA Standard (Akçelik M3D).

HV (%) values are calculated for All Movement Classes of All Heavy Vehicle Model Designation.

Arrival Flows used in performance calculations are adjusted to include any Initial Queued Demand and Upstream Capacity Constraint effects.

* Critical Movement (Signal Timing)

MOVEMENT SUMMARY

Site: 2859a [2859 Boulv_TheSand_AM (Site Folder: General)]

Output produced by SIDRA INTERSECTION Version: 9.1.6.228

Network: N101
[2048_Opt10B_AM (Network Folder: General)]

Site Category: (None)

Signals - EQUISAT (Fixed-Time/SCATS) Coordinated Cycle Time = 130 seconds (Network Optimum Cycle Time - Minimum Delay)

Vehicle Movement Performance															
Mov ID	Turn	Mov Class	Demand		Arrival		Deg. Satn	Aver. Delay	Level of Service	Aver. Back Of Queue		Prop. Que	Eff. Stop Rate	Aver. No. of Cycles	Aver. Speed
			[Total HV]	[Total HV]	[Total HV]	[Total HV]				[Veh. veh	Dist]				
			veh/h	%	veh/h	%	v/c	sec			m				km/h
South: The Sands Avenue															
1	L2	All MCs	451	6.3	451	6.3	0.290	5.1	LOS A	1.4	10.4	0.15	0.55	0.15	41.4
2	T1	All MCs	93	6.3	93	6.3	*0.321	30.7	LOS C	2.2	15.9	0.62	0.49	0.62	30.6
3	R2	All MCs	281	6.3	281	6.3	0.514	49.8	LOS D	4.6	34.0	0.87	0.77	0.87	20.0
Approach			824	6.3	824	6.3	0.514	23.2	LOS C	4.6	34.0	0.45	0.61	0.45	29.4
East: The Boulevard (E)															
4	L2	All MCs	143	6.3	143	6.3	0.319	21.8	LOS C	3.1	22.7	0.59	0.70	0.59	25.8
5	T1	All MCs	174	6.3	174	6.3	*0.317	54.3	LOS D	3.1	22.7	0.94	0.74	0.94	22.5
6	R2	All MCs	18	6.3	18	6.3	0.050	49.5	LOS D	0.6	4.1	0.84	0.68	0.84	26.9
Approach			335	6.3	335	6.3	0.319	40.2	LOS D	3.1	22.7	0.79	0.72	0.79	23.7
North: Wairakei Town Centre															
7	L2	All MCs	3	6.3	3	6.3	0.592	79.3	LOS E	1.2	8.7	1.00	0.79	1.13	21.8
8	T1	All MCs	49	6.3	49	6.3	0.592	74.9	LOS E	1.2	8.7	1.00	0.79	1.14	16.8
9	R2	All MCs	19	6.3	19	6.3	*0.231	73.1	LOS E	0.8	5.6	0.99	0.70	0.99	22.0
Approach			72	6.3	72	6.3	0.592	74.6	LOS E	1.2	8.7	1.00	0.77	1.10	18.6
West: The Boulevard (W)															
10	L2	All MCs	22	6.3	22	6.3	0.148	29.7	LOS C	2.7	20.0	0.66	0.57	0.66	33.9
11	T1	All MCs	207	6.3	207	6.3	0.148	25.0	LOS C	2.7	20.2	0.66	0.55	0.66	31.8
12	R2	All MCs	727	6.3	727	6.3	*0.902	47.4	LOS D	11.9	87.9	0.99	1.03	1.25	16.2
Approach			957	6.3	957	6.3	0.902	42.1	LOS D	11.9	87.9	0.91	0.92	1.11	20.1
All Vehicles			2187	6.3	2187	6.3	0.902	35.8	LOS D	11.9	87.9	0.72	0.77	0.81	23.6

Site Level of Service (LOS) Method: Delay (SIDRA). Site LOS Method is specified in the Network Data dialog (Override Site Data tab).

Vehicle movement LOS values are based on average delay per movement.

Intersection and Approach LOS values are based on average delay for all vehicle movements.

Delay Model: SIDRA Standard (Control Delay: Geometric Delay is included).

Queue Model: SIDRA queue estimation methods are used for Back of Queue and Queue at Start of Green.

Gap-Acceptance Capacity Formula: SIDRA Standard (Akçelik M3D).

HV (%) values are calculated for All Movement Classes of All Heavy Vehicle Model Designation.

Arrival Flows used in performance calculations are adjusted to include any Initial Queued Demand and Upstream Capacity Constraint effects.

* Critical Movement (Signal Timing)

Pedestrian Movement Performance											
Mov ID	Crossing	Dem. Flow	Aver. Delay	Level of Service	AVERAGE BACK OF QUEUE		Prop. Que	Eff. Stop Rate	Travel Time	Travel Dist.	Aver. Speed
					[Ped ped	Dist]					
		ped/h	sec			m			sec	m	m/sec

South: The Sands Avenue											
P1 Full	32	59.2	LOS E	0.1	0.1	0.96	0.96	74.6	20.0	0.27	
East: The Boulevard (E)											
P21 Stage 1	32	30.5	LOS D	0.1	0.1	0.91	0.91	45.9	20.0	0.44	
P22 Stage 2	32	59.2	LOS E	0.1	0.1	0.96	0.96	74.6	20.0	0.27	
North: Wairakei Town Centre											
P3 Full	32	59.2	LOS E	0.1	0.1	0.96	0.96	74.6	20.0	0.27	
West: The Boulevard (W)											
P4 Full	32	59.2	LOS E	0.1	0.1	0.96	0.96	74.6	20.0	0.27	
All Pedestrians	158	53.5	LOS E	0.1	0.1	0.95	0.95	68.9	20.0	0.29	

Level of Service (LOS) Method: SIDRA Pedestrian LOS Method (Based on Average Delay)

Pedestrian movement LOS values are based on average delay per pedestrian movement.

Intersection LOS value for Pedestrians is based on average delay for all pedestrian movements.

SIDRA INTERSECTION 9.1 | Copyright © 2000-2024 Kcelik and Associates Pty Ltd | sidrasolutions.com

Organisation: AJW | Licence: NETWORK / 1PC | Processed: Friday, 27 March 2026 5:53:41 pm

Project: C:\Users\annaj\OneDrive\AW Consulting\Projects\Boffa Miskell Jobs\Wairakei South\ITA Work Feb 2026\Final SIDRA Modelling\Third Round Base Sidra File\2048_TTHM 10B Mitigated.sip9

MOVEMENT SUMMARY

Site: 2860a [2860 The Sand_Bill Miller_AM (Site Folder: General)]

Output produced by SIDRA INTERSECTION Version: 9.1.6.228

Network: N101
[2048_Opt10B_AM (Network Folder: General)]

Site Category: (None)

Signals - EQUISAT (Fixed-Time/SCATS) Coordinated Cycle Time = 130 seconds (Network Optimum Cycle Time - Minimum Delay)

Vehicle Movement Performance													
Mov ID	Turn	Mov Class	Demand Flows [Total HV] veh/h %	Arrival Flows [Total HV] veh/h %	Deg. Satn v/c	Aver. Delay sec	Level of Service	Aver. Back Of Queue [Veh. veh]	Prop. Que	Eff. Stop Rate	Aver. No. of Cycles	Aver. Speed km/h	
South: The Sands Ave (S)													
1	L2	All MCs	14 10.1	14 10.1	0.009	4.7	LOS A	0.0	0.1	0.03	0.50	0.03	44.1
2	T1	All MCs	789 10.1	789 10.1	0.364	1.0	LOS A	0.9	6.8	0.06	0.05	0.06	45.5
3	R2	All MCs	87 10.1	87 10.1	*0.937	86.1	LOS F	3.9	29.6	1.00	0.97	1.36	17.4
Approach			891 10.1	891 10.1	0.937	9.4	LOS A	3.9	29.6	0.15	0.15	0.19	30.3
East: Bill Miller Dr (E)													
4	L2	All MCs	87 10.1	87 10.1	0.299	34.1	LOS C	2.5	18.8	0.76	0.74	0.76	26.3
5	T1	All MCs	1 10.1	1 10.1	0.005	53.3	LOS D	0.0	0.3	0.89	0.54	0.89	29.1
6	R2	All MCs	18 10.1	18 10.1	*0.224	73.3	LOS E	0.7	5.4	0.99	0.70	0.99	17.0
Approach			106 10.1	106 10.1	0.299	40.9	LOS D	2.5	18.8	0.80	0.73	0.80	24.1
North: The Sands Ave (N)													
7	L2	All MCs	79 10.1	79 10.1	0.051	5.0	LOS A	0.2	1.5	0.10	0.52	0.10	43.9
8	T1	All MCs	1016 10.1	1016 10.1	*0.961	68.4	LOS E	19.1	145.0	1.00	1.22	1.36	7.3
9	R2	All MCs	7 10.1	7 10.1	0.079	70.6	LOS E	0.3	2.2	0.98	0.66	0.98	19.9
Approach			1102 10.1	1102 10.1	0.961	63.9	LOS E	19.1	145.0	0.94	1.17	1.27	9.2
West: Bill Miller Dr (W)													
10	L2	All MCs	16 10.1	16 10.1	0.041	46.9	LOS D	0.5	3.6	0.81	0.68	0.81	22.1
Approach			16 10.1	16 10.1	0.041	46.9	LOS D	0.5	3.6	0.81	0.68	0.81	22.1
All Vehicles			2115 10.1	2115 10.1	0.961	39.7	LOS D	19.1	145.0	0.60	0.71	0.79	14.3

Site Level of Service (LOS) Method: Delay (SIDRA). Site LOS Method is specified in the Network Data dialog (Override Site Data tab).

Vehicle movement LOS values are based on average delay per movement.

Intersection and Approach LOS values are based on average delay for all vehicle movements.

Delay Model: SIDRA Standard (Control Delay: Geometric Delay is included).

Queue Model: SIDRA queue estimation methods are used for Back of Queue and Queue at Start of Green.

Gap-Acceptance Capacity Formula: SIDRA Standard (Akçelik M3D).

HV (%) values are calculated for All Movement Classes of All Heavy Vehicle Model Designation.

Arrival Flows used in performance calculations are adjusted to include any Initial Queued Demand and Upstream Capacity Constraint effects.

* Critical Movement (Signal Timing)

Pedestrian Movement Performance											
Mov ID	Crossing	Dem. Flow ped/h	Aver. Delay sec	Level of Service	AVERAGE BACK OF QUEUE [Ped Dist] ped m		Prop. Que	Eff. Stop Rate	Travel Time sec	Travel Dist. m	Aver. Speed m/sec
South: The Sands Ave (S)											
P1	Full	32	59.2	LOS E	0.1	0.1	0.96	0.96	74.6	20.0	0.27

East: Bill Miller Dr (E)											
P2	Full	32	59.2	LOS E	0.1	0.1	0.96	0.96	74.6	20.0	0.27
North: The Sands Ave (N)											
P3	Full	32	59.2	LOS E	0.1	0.1	0.96	0.96	74.6	20.0	0.27
West: Bill Miller Dr (W)											
P4	Full	32	59.2	LOS E	0.1	0.1	0.96	0.96	74.6	20.0	0.27
All Pedestrians		126	59.2	LOS E	0.1	0.1	0.96	0.96	74.6	20.0	0.27

Level of Service (LOS) Method: SIDRA Pedestrian LOS Method (Based on Average Delay)

Pedestrian movement LOS values are based on average delay per pedestrian movement.

Intersection LOS value for Pedestrians is based on average delay for all pedestrian movements.

SIDRA INTERSECTION 9.1 | Copyright © 2000-2024 Akcelik and Associates Pty Ltd | sidrasolutions.com

Organisation: AJW | Licence: NETWORK / 1PC | Processed: Friday, 27 March 2026 5:53:41 pm

Project: C:\Users\annaj\OneDrive\AW Consulting\Projects\Boffa Miskell Jobs\Wairakei South\ITA Work Feb 2026\Final SIDRA Modelling\Third Round Base Sidra File\2048_TTHM 10B Mitigated.sip9

MOVEMENT SUMMARY

Site: 2514a [2514 Sands_Te Okuroa_AM (Site Folder: General)]

Output produced by SIDRA INTERSECTION Version: 9.1.6.228

Network: N101
[2048_Opt10B_AM (Network Folder: General)]

Site Category: (None)

Signals - EQUISAT (Fixed-Time/SCATS) Coordinated Cycle Time = 130 seconds (Network Optimum Cycle Time - Minimum Delay)

Vehicle Movement Performance													
Mov ID	Turn	Mov Class	Demand Flows [Total HV]	Arrival Flows [Total HV]	Deg. Satn	Aver. Delay	Level of Service	Aver. Back Of Queue [Veh.]	Prop. Que	Eff. Stop Rate	Aver. No. of Cycles	Aver. Speed	
			veh/h %	veh/h %	v/c	sec		Dist] m				km/h	
South: The Sand Ave (S)													
1	L2	All MCs	277 10.6	277 10.6	0.196	9.6	LOS A	1.2	9.5	0.18	0.56	0.18	44.3
2	T1	All MCs	805 10.6	805 10.6	0.775	32.5	LOS C	14.2	108.2	0.84	0.75	0.86	19.6
3	R2	All MCs	767 10.6	767 10.6	*0.996	99.7	LOS F	19.1	146.0	1.00	1.13	1.37	17.8
Approach			1849 10.6	1849 10.6	0.996	57.0	LOS E	19.1	146.0	0.81	0.88	0.97	20.5
East: Te Okuroa Dr (E)													
4	L2	All MCs	936 10.6	936 10.6	0.776	43.3	LOS D	16.2	124.0	0.93	0.88	0.96	23.7
5	T1	All MCs	63 10.6	63 10.6	*0.225	52.5	LOS D	2.2	16.6	0.92	0.71	0.92	29.3
6	R2	All MCs	47 10.6	47 10.6	0.178	56.8	LOS E	1.6	12.4	0.91	0.73	0.91	19.9
Approach			1046 10.6	1046 10.6	0.776	44.5	LOS D	16.2	124.0	0.93	0.86	0.95	23.7
North: The Sand Ave (N)													
7	L2	All MCs	124 10.6	124 10.6	1.031	120.1	LOS F	17.3	132.0	1.00	1.34	1.53	14.4
8	T1	All MCs	954 10.6	954 10.6	*1.031	122.3	LOS F	17.3	132.0	1.00	1.36	1.53	4.5
9	R2	All MCs	34 10.6	34 10.6	0.087	72.5	LOS E	1.2	9.2	0.97	0.74	0.97	22.6
Approach			1112 10.6	1112 10.6	1.031	120.6	LOS F	17.3	132.0	1.00	1.34	1.51	6.0
West: Te Okuroa Dr (W)													
10	L2	All MCs	37 10.6	37 10.6	0.940	46.5	LOS D	10.3	78.9	1.00	1.15	1.41	15.7
11	T1	All MCs	186 10.6	186 10.6	*0.940	90.8	LOS F	10.3	78.9	1.00	1.15	1.41	23.5
12	R2	All MCs	385 10.6	385 10.6	0.871	75.2	LOS E	8.5	64.8	1.00	1.01	1.27	16.8
Approach			608 10.6	608 10.6	0.940	78.3	LOS E	10.3	78.9	1.00	1.06	1.33	19.3
All Vehicles			4616 10.6	4616 10.6	1.031	72.3	LOS E	19.1	146.0	0.91	1.01	1.14	16.4

Site Level of Service (LOS) Method: Delay (SIDRA). Site LOS Method is specified in the Network Data dialog (Override Site Data tab).

Vehicle movement LOS values are based on average delay per movement.

Intersection and Approach LOS values are based on average delay for all vehicle movements.

Delay Model: SIDRA Standard (Control Delay: Geometric Delay is included).

Queue Model: SIDRA queue estimation methods are used for Back of Queue and Queue at Start of Green.

Gap-Acceptance Capacity Formula: SIDRA Standard (Akçelik M3D).

HV (%) values are calculated for All Movement Classes of All Heavy Vehicle Model Designation.

Arrival Flows used in performance calculations are adjusted to include any Initial Queued Demand and Upstream Capacity Constraint effects.

* Critical Movement (Signal Timing)

Pedestrian Movement Performance											
Mov ID	Crossing	Dem. Flow	Aver. Delay	Level of Service	AVERAGE BACK OF QUEUE [Ped Dist]		Prop. Que	Eff. Stop Rate	Travel Time	Travel Dist.	Aver. Speed
		ped/h	sec		ped	m			sec	m	m/sec

South: The Sand Ave (S)											
P1	Full	32	59.2	LOS E	0.1	0.1	0.96	0.96	74.6	20.0	0.27
East: Te Okuroa Dr (E)											
P2	Full	32	59.2	LOS E	0.1	0.1	0.96	0.96	74.6	20.0	0.27
P2B	Slip/ Bypass	32	59.2	LOS E	0.1	0.1	0.96	0.96	74.6	20.0	0.27
North: The Sand Ave (N)											
P3	Full	32	59.2	LOS E	0.1	0.1	0.96	0.96	74.6	20.0	0.27
West: Te Okuroa Dr (W)											
P4	Full	32	59.2	LOS E	0.1	0.1	0.96	0.96	74.6	20.0	0.27
All Pedestrians		158	59.2	LOS E	0.1	0.1	0.96	0.96	74.6	20.0	0.27

Level of Service (LOS) Method: SIDRA Pedestrian LOS Method (Based on Average Delay)

Pedestrian movement LOS values are based on average delay per pedestrian movement.

Intersection LOS value for Pedestrians is based on average delay for all pedestrian movements.

SIDRA INTERSECTION 9.1 | Copyright © 2000-2024 Akcelik and Associates Pty Ltd | sidrasolutions.com

Organisation: AJW | Licence: NETWORK / 1PC | Processed: Friday, 27 March 2026 5:53:41 pm

Project: C:\Users\annaj\OneDrive\AW Consulting\Projects\Boffa Miskell Jobs\Wairakei South\ITA Work Feb 2026\Final SIDRA Modelling\Third Round Base Sidra File\2048_TTHM 10B Mitigated.sip9

MOVEMENT SUMMARY

Site: 10003a [10003_AM (Site Folder: General)]

Output produced by SIDRA INTERSECTION Version: 9.1.6.228

Network: N101
[2048_Opt10B_AM (Network Folder: General)]

NA

Site Category: (None)

Signals - EQUISAT (Fixed-Time/SCATS) Isolated Cycle Time = 80 seconds (Site Practical Cycle Time)

Vehicle Movement Performance															
Mov ID	Turn	Mov Class	Demand Flows		Arrival Flows		Deg. Satn	Aver. Delay	Level of Service	Aver. Back Of Queue	Prop. Que	Eff. Stop Rate	Aver. No. of Cycles	Aver. Speed	
			[Total HV]	%	[Total HV]	%	v/c	sec		[Veh. veh	Dist]			km/h	
			veh/h		veh/h					veh	m				
South: Road 2															
1	L2	All MCs	4	9.9	4	9.9	0.029	27.4	LOS C	0.2	1.4	0.84	0.61	0.84	14.2
2	T1	All MCs	5	9.9	5	9.9	0.029	33.8	LOS C	0.2	1.4	0.84	0.61	0.84	30.5
3	R2	All MCs	298	9.9	298	9.9	*0.528	39.1	LOS D	3.4	25.9	0.96	0.79	0.96	11.9
Approach			307	9.9	307	9.9	0.528	38.9	LOS D	3.4	25.9	0.96	0.79	0.96	12.4
East: Road 1															
4	L2	All MCs	63	9.9	63	9.9	0.043	5.1	LOSA	0.1	0.9	0.16	0.54	0.16	41.6
5	T1	All MCs	433	9.9	429	9.9	0.390	24.2	LOS C	4.1	31.4	0.84	0.70	0.84	26.2
6	R2	All MCs	48	9.9	48	9.9	*0.369	45.6	LOS D	1.2	9.0	0.99	0.74	0.99	28.5
Approach			544	9.9	540	9.9	0.390	23.9	LOS C	4.1	31.4	0.77	0.68	0.77	28.1
North: Road 2															
7	L2	All MCs	115	9.9	115	9.9	0.125	10.2	LOS B	1.0	7.7	0.47	0.64	0.47	39.3
8	T1	All MCs	4	9.9	4	9.9	*0.093	31.5	LOS C	0.5	4.2	0.88	0.69	0.88	28.9
9	R2	All MCs	22	9.9	22	9.9	0.093	36.1	LOS D	0.5	4.2	0.88	0.69	0.88	25.8
Approach			141	9.9	141	9.9	0.125	14.9	LOS B	1.0	7.7	0.55	0.65	0.55	35.9
West: Road 1															
10	L2	All MCs	21	9.9	21	9.9	0.736	18.3	LOS B	9.2	69.6	0.95	0.87	1.01	34.5
11	T1	All MCs	788	9.9	788	9.9	*0.736	29.5	LOS C	9.2	69.8	0.96	0.87	1.02	26.4
12	R2	All MCs	12	9.9	12	9.9	0.089	44.5	LOS D	0.3	2.1	0.96	0.67	0.96	24.0
Approach			821	9.9	821	9.9	0.736	29.4	LOS C	9.2	69.8	0.96	0.87	1.01	26.6
All Vehicles			1814	9.9	1809	9.9	0.736	28.2	LOS C	9.2	69.8	0.87	0.78	0.90	25.5

Site Level of Service (LOS) Method: Delay (SIDRA). Site LOS Method is specified in the Network Data dialog (Override Site Data tab).

Vehicle movement LOS values are based on average delay per movement.

Intersection and Approach LOS values are based on average delay for all vehicle movements.

Delay Model: SIDRA Standard (Control Delay; Geometric Delay is included).

Queue Model: SIDRA queue estimation methods are used for Back of Queue and Queue at Start of Green.

Gap-Acceptance Capacity Formula: SIDRA Standard (Akçelik M3D).

HV (%) values are calculated for All Movement Classes of All Heavy Vehicle Model Designation.

Arrival Flows used in performance calculations are adjusted to include any Initial Queued Demand and Upstream Capacity Constraint effects.

* Critical Movement (Signal Timing)

Pedestrian Movement Performance											
Mov ID	Crossing	Dem. Flow	Aver. Delay	Level of Service	AVERAGE BACK OF QUEUE		Prop. Que	Eff. Stop Rate	Travel Time	Travel Dist.	Aver. Speed
		ped/h	sec		[Ped ped	Dist]			sec	m	m/sec
					ped	m					
South: Road 2											
P1	Full	32	34.3	LOS D	0.1	0.1	0.93	0.93	188.1	200.0	1.06

East: Road 1											
P2	Full	32	34.3	LOS D	0.1	0.1	0.93	0.93	188.1	200.0	1.06
North: Road 2											
P3	Full	32	34.3	LOS D	0.1	0.1	0.93	0.93	188.1	200.0	1.06
West: Road 1											
P4	Full	32	34.3	LOS D	0.1	0.1	0.93	0.93	188.1	200.0	1.06
All Pedestrians		126	34.3	LOS D	0.1	0.1	0.93	0.93	188.1	200.0	1.06

Level of Service (LOS) Method: SIDRA Pedestrian LOS Method (Based on Average Delay)

Pedestrian movement LOS values are based on average delay per pedestrian movement.

Intersection LOS value for Pedestrians is based on average delay for all pedestrian movements.

SIDRA INTERSECTION 9.1 | Copyright © 2000-2024 Akcelik and Associates Pty Ltd | sidrasolutions.com

Organisation: AJW | Licence: NETWORK / 1PC | Processed: Friday, 27 March 2026 5:53:41 pm

Project: C:\Users\annaj\OneDrive\AW Consulting\Projects\Boffa Miskell Jobs\Wairakei South\ITA Work Feb 2026\Final SIDRA Modelling\Third Round Base Sidra File\2048_TTHM 10B Mitigated.sip9

MOVEMENT SUMMARY

Site: 10007a [10007_AM (Site Folder: General)]

Output produced by SIDRA INTERSECTION Version: 9.1.6.228

Network: N101
[2048_Opt10B_AM (Network Folder: General)]

NA

Site Category: (None)

Signals - EQUISAT (Fixed-Time/SCATS) Isolated Cycle Time = 70 seconds (Site Practical Cycle Time)

Vehicle Movement Performance															
Mov ID	Turn	Mov Class	Demand Flows		Arrival Flows		Deg. Satn	Aver. Delay	Level of Service	Aver. Back Of Queue		Prop. Que	Eff. Stop Rate	Aver. No. of Cycles	Aver. Speed
			[Total HV]	[Total HV]	[Total HV]	[Total HV]	v/c	sec		[Veh. veh	Dist]				km/h
			veh/h	%	veh/h	%				veh	m				
SouthEast: Road 4															
21	L2	All MCs	41	10.9	41	10.9	0.099	23.9	LOS C	0.8	6.0	0.75	0.68	0.75	31.0
22	T1	All MCs	11	10.9	11	10.9	0.099	19.2	LOS B	0.8	6.0	0.75	0.68	0.75	37.9
23	R2	All MCs	3	10.9	3	10.9	0.021	37.7	LOS D	0.1	0.5	0.94	0.62	0.94	24.9
Approach			55	10.9	55	10.9	0.099	23.8	LOS C	0.8	6.0	0.76	0.68	0.76	32.4
NorthEast: Road 1															
24	L2	All MCs	2	10.9	2	10.9	0.550	35.5	LOS D	3.2	24.4	0.97	0.78	0.97	33.6
25	T1	All MCs	315	10.9	312	10.9	0.550	30.8	LOS C	3.2	24.5	0.97	0.78	0.97	25.4
26	R2	All MCs	143	10.9	142	10.9	*0.721	40.9	LOS D	3.2	24.5	1.00	0.90	1.19	30.4
Approach			460	10.9	456	10.9	0.721	34.0	LOS C	3.2	24.5	0.98	0.82	1.04	27.7
NorthWest: Road 4															
27	L2	All MCs	404	10.9	404	10.9	0.797	33.6	LOS C	9.0	68.7	0.98	0.94	1.14	25.8
28	T1	All MCs	8	10.9	8	10.9	*0.797	29.0	LOS C	9.0	68.7	0.98	0.94	1.14	34.1
29	R2	All MCs	6	10.9	6	10.9	*0.043	38.0	LOS D	0.1	1.0	0.94	0.65	0.94	24.3
Approach			419	10.9	419	10.9	0.797	33.6	LOS C	9.0	68.7	0.98	0.93	1.14	26.0
SouthWest: Road 1															
30	L2	All MCs	6	10.9	6	10.9	0.723	38.2	LOS D	4.5	34.5	1.00	0.90	1.14	29.1
31	T1	All MCs	407	10.9	407	10.9	*0.723	33.5	LOS C	4.5	34.6	1.00	0.90	1.14	15.7
32	R2	All MCs	29	10.9	29	10.9	0.150	36.4	LOS D	0.6	4.5	0.93	0.71	0.93	28.6
Approach			443	10.9	443	10.9	0.723	33.8	LOS C	4.5	34.6	1.00	0.89	1.13	17.5
All Vehicles			1377	10.9	1373	10.9	0.797	33.4	LOS C	9.0	68.7	0.98	0.87	1.09	24.8

Site Level of Service (LOS) Method: Delay (SIDRA). Site LOS Method is specified in the Network Data dialog (Override Site Data tab).

Vehicle movement LOS values are based on average delay per movement.

Intersection and Approach LOS values are based on average delay for all vehicle movements.

Delay Model: SIDRA Standard (Control Delay; Geometric Delay is included).

Queue Model: SIDRA queue estimation methods are used for Back of Queue and Queue at Start of Green.

Gap-Acceptance Capacity Formula: SIDRA Standard (Akçelik M3D).

HV (%) values are calculated for All Movement Classes of All Heavy Vehicle Model Designation.

Arrival Flows used in performance calculations are adjusted to include any Initial Queued Demand and Upstream Capacity Constraint effects.

* Critical Movement (Signal Timing)

Pedestrian Movement Performance											
Mov ID	Crossing	Dem. Flow	Aver. Delay	Level of Service	AVERAGE BACK OF QUEUE		Prop. Que	Eff. Stop Rate	Travel Time	Travel Dist.	Aver. Speed
		ped/h	sec		[Ped ped	Dist]			sec	m	m/sec
					ped	m					
SouthEast: Road 4											
P5	Full	32	29.3	LOS C	0.1	0.1	0.92	0.92	183.1	200.0	1.09

NorthEast: Road 1											
P6	Full	32	29.3	LOS C	0.1	0.1	0.92	0.92	183.1	200.0	1.09
NorthWest: Road 4											
P7	Full	32	29.3	LOS C	0.1	0.1	0.92	0.92	183.1	200.0	1.09
SouthWest: Road 1											
P8	Full	32	29.3	LOS C	0.1	0.1	0.92	0.92	183.1	200.0	1.09
All Pedestrians		126	29.3	LOS C	0.1	0.1	0.92	0.92	183.1	200.0	1.09

Level of Service (LOS) Method: SIDRA Pedestrian LOS Method (Based on Average Delay)

Pedestrian movement LOS values are based on average delay per pedestrian movement.

Intersection LOS value for Pedestrians is based on average delay for all pedestrian movements.

SIDRA INTERSECTION 9.1 | Copyright © 2000-2024 Akcelik and Associates Pty Ltd | sidrasolutions.com

Organisation: AJW | Licence: NETWORK / 1PC | Processed: Friday, 27 March 2026 5:53:41 pm

Project: C:\Users\annaj\OneDrive\AW Consulting\Projects\Boffa Miskell Jobs\Wairakei South\ITA Work Feb 2026\Final SIDRA Modelling\Third Round Base Sidra File\2048_TTHM 10B Mitigated.sip9

MOVEMENT SUMMARY

Site: 10008a [10008_AM (Site Folder: General)]

Output produced by SIDRA INTERSECTION Version: 9.1.6.228

Network: N101
[2048_Opt10B_AM (Network Folder: General)]

New Site

Site Category: (None)

Signals - EQUISAT (Fixed-Time/SCATS) Isolated Cycle Time = 70 seconds (Site Practical Cycle Time)

Vehicle Movement Performance															
Mov ID	Turn	Mov Class	Demand Flows		Arrival Flows		Deg. Satn	Aver. Delay	Level of Service	Aver. Back Of Queue		Prop. Que	Eff. Stop Rate	Aver. No. of Cycles	Aver. Speed
			[Total HV]	[Total HV]	[Total HV]	[Total HV]	v/c	sec		[Veh. veh	Dist]				km/h
			veh/h	%	veh/h	%					m				
South: Road 1															
1	L2	All MCs	4	16.8	4	16.8	0.271	23.1	LOS C	1.4	11.5	0.91	0.71	0.91	26.7
2	T1	All MCs	146	16.8	146	16.8	0.271	29.1	LOS C	1.4	11.6	0.91	0.71	0.91	26.6
3	R2	All MCs	9	16.8	9	16.8	0.033	31.3	LOS C	0.2	1.4	0.86	0.66	0.86	34.3
Approach			160	16.8	160	16.8	0.271	29.1	LOS C	1.4	11.6	0.91	0.70	0.91	27.3
East: Bell Road															
4	L2	All MCs	15	16.8	15	16.8	0.012	5.5	LOS A	0.0	0.3	0.22	0.54	0.22	44.1
5	T1	All MCs	21	16.8	21	16.8	0.049	22.1	LOS C	0.3	2.7	0.79	0.57	0.79	32.6
6	R2	All MCs	3	16.8	3	16.8	0.022	37.8	LOS D	0.1	0.5	0.94	0.62	0.94	26.1
Approach			39	16.8	39	16.8	0.049	17.1	LOS B	0.3	2.7	0.59	0.56	0.59	35.3
North: Road 1															
7	L2	All MCs	1	16.8	1	16.8	0.002	21.4	LOS C	0.0	0.1	0.69	0.58	0.69	35.0
8	T1	All MCs	208	16.8	207	16.8	*0.375	29.9	LOS C	2.0	16.3	0.94	0.74	0.94	17.2
9	R2	All MCs	155	16.8	154	16.8	*0.541	34.7	LOS C	3.1	24.8	0.96	0.80	0.96	15.6
Approach			364	16.8	362	16.8	0.541	31.9	LOS C	3.1	24.8	0.95	0.76	0.95	16.6
West: Bell Road															
10	L2	All MCs	294	16.8	294	16.8	0.226	5.6	LOS A	0.9	7.1	0.26	0.58	0.26	42.7
11	T1	All MCs	23	16.8	23	16.8	*0.054	22.2	LOS C	0.4	3.0	0.80	0.58	0.80	38.3
12	R2	All MCs	7	16.8	7	16.8	*0.052	38.2	LOS D	0.1	1.2	0.94	0.66	0.94	23.2
Approach			324	16.8	324	16.8	0.226	7.5	LOS A	0.9	7.1	0.31	0.58	0.31	41.3
All Vehicles			887	16.8	885	16.8	0.541	21.8	LOS C	3.1	24.8	0.69	0.68	0.69	28.0

Site Level of Service (LOS) Method: Delay (SIDRA). Site LOS Method is specified in the Network Data dialog (Override Site Data tab).

Vehicle movement LOS values are based on average delay per movement.

Intersection and Approach LOS values are based on average delay for all vehicle movements.

Delay Model: SIDRA Standard (Control Delay; Geometric Delay is included).

Queue Model: SIDRA queue estimation methods are used for Back of Queue and Queue at Start of Green.

Gap-Acceptance Capacity Formula: SIDRA Standard (Akçelik M3D).

HV (%) values are calculated for All Movement Classes of All Heavy Vehicle Model Designation.

Arrival Flows used in performance calculations are adjusted to include any Initial Queued Demand and Upstream Capacity Constraint effects.

* Critical Movement (Signal Timing)

Pedestrian Movement Performance											
Mov ID	Crossing	Dem. Flow	Aver. Delay	Level of Service	AVERAGE BACK OF QUEUE		Prop. Que	Eff. Stop Rate	Travel Time	Travel Dist.	Aver. Speed
		ped/h	sec		[Ped ped	Dist]			sec	m	m/sec
						m					
South: Road 1											
P1	Full	32	29.3	LOS C	0.1	0.1	0.92	0.92	183.1	200.0	1.09

East: Bell Road											
P2	Full	32	29.3	LOS C	0.1	0.1	0.92	0.92	183.1	200.0	1.09
North: Road 1											
P3	Full	32	29.3	LOS C	0.1	0.1	0.92	0.92	183.1	200.0	1.09
West: Bell Road											
P4	Full	32	29.3	LOS C	0.1	0.1	0.92	0.92	183.1	200.0	1.09
All Pedestrians		126	29.3	LOS C	0.1	0.1	0.92	0.92	183.1	200.0	1.09

Level of Service (LOS) Method: SIDRA Pedestrian LOS Method (Based on Average Delay)

Pedestrian movement LOS values are based on average delay per pedestrian movement.

Intersection LOS value for Pedestrians is based on average delay for all pedestrian movements.

SIDRA INTERSECTION 9.1 | Copyright © 2000-2024 Akcelik and Associates Pty Ltd | sidrasolutions.com

Organisation: AJW | Licence: NETWORK / 1PC | Processed: Friday, 27 March 2026 5:53:41 pm

Project: C:\Users\annaj\OneDrive\AW Consulting\Projects\Boffa Miskell Jobs\Wairakei South\ITA Work Feb 2026\Final SIDRA Modelling\Third Round Base Sidra File\2048_TTHM 10B Mitigated.sip9

MOVEMENT SUMMARY

Site: 10015a [10015_AM (Site Folder: General)]

Output produced by SIDRA INTERSECTION Version: 9.1.6.228

Network: N101
[2048_Opt10B_AM (Network Folder: General)]

New Site

Site Category: (None)

Signals - EQUISAT (Fixed-Time/SCATS) Isolated Cycle Time = 70 seconds (Site Practical Cycle Time)

Vehicle Movement Performance															
Mov ID	Turn	Mov Class	Demand Flows [Total HV]		Arrival Flows [Total HV]		Deg. Satn	Aver. Delay	Level of Service	Aver. Back Of Queue		Prop. Que	Eff. Stop Rate	Aver. No. of Cycles	Aver. Speed
			veh/h	%	veh/h	%	v/c	sec		[Veh. veh	Dist] m				km/h
South: Road 1															
1	L2	All MCs	2	19.5	2	19.5	0.087	22.5	LOS C	0.4	3.5	0.87	0.64	0.87	35.2
2	T1	All MCs	45	19.5	45	19.5	0.087	28.1	LOS C	0.4	3.6	0.88	0.64	0.88	27.0
3	R2	All MCs	1	19.5	1	19.5	0.004	30.8	LOS C	0.0	0.2	0.84	0.59	0.84	33.8
Approach			48	19.5	48	19.5	0.087	27.9	LOS C	0.4	3.6	0.88	0.63	0.88	27.8
East: Road 6															
4	L2	All MCs	1	19.5	1	19.5	0.017	14.7	LOS B	0.1	0.9	0.77	0.54	0.77	31.7
5	T1	All MCs	6	19.5	6	19.5	0.017	22.8	LOS C	0.1	0.9	0.77	0.54	0.77	38.9
6	R2	All MCs	28	19.5	28	19.5	*0.203	39.3	LOS D	0.6	4.9	0.96	0.71	0.96	24.4
Approach			36	19.5	36	19.5	0.203	35.7	LOS D	0.6	4.9	0.92	0.68	0.92	27.7
North: Road 1															
7	L2	All MCs	47	19.5	47	19.5	0.088	22.4	LOS C	0.7	5.6	0.72	0.70	0.72	36.8
8	T1	All MCs	67	19.5	67	19.5	*0.160	28.4	LOS C	0.8	6.7	0.89	0.66	0.89	26.7
9	R2	All MCs	60	19.5	60	19.5	*0.214	32.8	LOS C	1.1	9.2	0.90	0.74	0.90	33.5
Approach			175	19.5	174	19.5	0.214	28.3	LOS C	1.1	9.2	0.85	0.70	0.85	32.6
West: Road 6															
10	L2	All MCs	40	19.5	40	19.5	0.143	17.5	LOS B	1.1	8.7	0.77	0.67	0.77	32.0
11	T1	All MCs	28	19.5	28	19.5	*0.143	29.3	LOS C	1.1	8.7	0.77	0.67	0.77	38.6
12	R2	All MCs	3	19.5	3	19.5	0.023	37.9	LOS D	0.1	0.5	0.94	0.62	0.94	25.5
Approach			72	19.5	72	19.5	0.143	23.1	LOS C	1.1	8.7	0.77	0.67	0.77	35.0
All Vehicles			331	19.5	330	19.6	0.214	27.9	LOS C	1.1	9.2	0.84	0.68	0.84	32.0

Site Level of Service (LOS) Method: Delay (SIDRA). Site LOS Method is specified in the Network Data dialog (Override Site Data tab).

Vehicle movement LOS values are based on average delay per movement.

Intersection and Approach LOS values are based on average delay for all vehicle movements.

Delay Model: SIDRA Standard (Control Delay; Geometric Delay is included).

Queue Model: SIDRA queue estimation methods are used for Back of Queue and Queue at Start of Green.

Gap-Acceptance Capacity Formula: SIDRA Standard (Akçelik M3D).

HV (%) values are calculated for All Movement Classes of All Heavy Vehicle Model Designation.

Arrival Flows used in performance calculations are adjusted to include any Initial Queued Demand and Upstream Capacity Constraint effects.

* Critical Movement (Signal Timing)

Pedestrian Movement Performance											
Mov ID	Crossing	Dem. Flow	Aver. Delay	Level of Service	AVERAGE BACK OF QUEUE		Prop. Que	Eff. Stop Rate	Travel Time	Travel Dist.	Aver. Speed
		ped/h	sec		[Ped ped	Dist] m			sec	m	m/sec
South: Road 1											
P1	Full	32	29.3	LOS C	0.1	0.1	0.92	0.92	183.1	200.0	1.09

East: Road 6											
P2	Full	32	29.3	LOS C	0.1	0.1	0.92	0.92	183.1	200.0	1.09
North: Road 1											
P3	Full	32	29.3	LOS C	0.1	0.1	0.92	0.92	183.1	200.0	1.09
West: Road 6											
P4	Full	32	29.3	LOS C	0.1	0.1	0.92	0.92	183.1	200.0	1.09
All Pedestrians		126	29.3	LOS C	0.1	0.1	0.92	0.92	183.1	200.0	1.09

Level of Service (LOS) Method: SIDRA Pedestrian LOS Method (Based on Average Delay)

Pedestrian movement LOS values are based on average delay per pedestrian movement.

Intersection LOS value for Pedestrians is based on average delay for all pedestrian movements.

SIDRA INTERSECTION 9.1 | Copyright © 2000-2024 Akcelik and Associates Pty Ltd | sidrasolutions.com

Organisation: AJW | Licence: NETWORK / 1PC | Processed: Friday, 27 March 2026 5:53:41 pm

Project: C:\Users\annaj\OneDrive\AW Consulting\Projects\Boffa Miskell Jobs\Wairakei South\ITA Work Feb 2026\Final SIDRA Modelling\Third Round Base Sidra File\2048_TTHM 10B Mitigated.sip9

MOVEMENT SUMMARY

Site: 10016a [10016_AM (Site Folder: General)]

Output produced by SIDRA INTERSECTION Version: 9.1.6.228

Network: N101
[2048_Opt10B_AM (Network Folder: General)]

New Site

Site Category: (None)

Signals - EQUISAT (Fixed-Time/SCATS) Isolated Cycle Time = 60 seconds (Site Practical Cycle Time)

Vehicle Movement Performance															
Mov ID	Turn	Mov Class	Demand Flows		Arrival Flows		Deg. Satn	Aver. Delay	Level of Service	Aver. Back Of Queue		Prop. Que	Eff. Stop Rate	Aver. No. of Cycles	Aver. Speed
			[Total HV] veh/h	%	[Total HV] veh/h	%				[Veh. veh	Dist] m				
South: Road 1															
1	L2	All MCs	1	18.5	1	18.5	0.009	18.1	LOS B	0.0	0.4	0.80	0.55	0.80	38.5
2	T1	All MCs	2	18.5	2	18.5	0.009	23.5	LOS C	0.0	0.4	0.80	0.55	0.80	31.6
3	R2	All MCs	1	18.5	1	18.5	0.005	29.5	LOS C	0.0	0.1	0.88	0.59	0.88	34.8
Approach			4	18.5	4	18.5	0.009	23.6	LOS C	0.0	0.4	0.82	0.56	0.82	34.8
East: Road 7															
4	L2	All MCs	1	18.5	1	18.5	0.016	16.7	LOS B	0.1	0.6	0.82	0.56	0.82	37.5
5	T1	All MCs	4	18.5	4	18.5	0.016	23.4	LOS C	0.1	0.6	0.82	0.56	0.82	39.2
6	R2	All MCs	17	18.5	17	18.5	*0.103	33.0	LOS C	0.3	2.4	0.94	0.69	0.94	26.5
Approach			22	18.5	22	18.5	0.103	30.4	LOS C	0.3	2.4	0.91	0.66	0.91	30.3
North: Road 1															
7	L2	All MCs	31	18.5	30	18.5	0.053	17.7	LOS B	0.4	3.0	0.67	0.67	0.67	38.7
8	T1	All MCs	1	18.5	1	18.5	*0.053	22.8	LOS C	0.4	3.0	0.67	0.67	0.67	39.8
9	R2	All MCs	40	18.5	40	18.5	*0.182	31.2	LOS C	0.7	5.5	0.92	0.72	0.92	34.7
Approach			72	18.5	71	18.5	0.182	25.3	LOS C	0.7	5.5	0.81	0.70	0.81	36.3
West: Road 7															
10	L2	All MCs	31	18.5	31	18.5	0.120	19.0	LOS B	0.7	5.6	0.81	0.68	0.81	33.3
11	T1	All MCs	18	18.5	18	18.5	*0.120	27.9	LOS C	0.7	5.6	0.81	0.68	0.81	39.2
12	R2	All MCs	1	18.5	1	18.5	0.006	31.9	LOS C	0.0	0.1	0.92	0.59	0.92	35.0
Approach			49	18.5	49	18.5	0.120	22.5	LOS C	0.7	5.6	0.81	0.67	0.81	36.1
All Vehicles			147	18.5	147	18.5	0.182	25.1	LOS C	0.7	5.6	0.83	0.68	0.83	35.4

Site Level of Service (LOS) Method: Delay (SIDRA). Site LOS Method is specified in the Network Data dialog (Override Site Data tab).

Vehicle movement LOS values are based on average delay per movement.

Intersection and Approach LOS values are based on average delay for all vehicle movements.

Delay Model: SIDRA Standard (Control Delay; Geometric Delay is included).

Queue Model: SIDRA queue estimation methods are used for Back of Queue and Queue at Start of Green.

Gap-Acceptance Capacity Formula: SIDRA Standard (Akçelik M3D).

HV (%) values are calculated for All Movement Classes of All Heavy Vehicle Model Designation.

Arrival Flows used in performance calculations are adjusted to include any Initial Queued Demand and Upstream Capacity Constraint effects.

* Critical Movement (Signal Timing)

Pedestrian Movement Performance											
Mov ID	Crossing	Dem. Flow	Aver. Delay	Level of Service	AVERAGE BACK OF QUEUE		Prop. Que	Eff. Stop Rate	Travel Time	Travel Dist.	Aver. Speed
					[Ped ped	Dist] m					
		ped/h	sec					sec	m	m/sec	
South: Road 1											
P1	Full	32	24.3	LOS C	0.0	0.0	0.90	0.90	178.2	200.0	1.12

East: Road 7											
P2	Full	32	24.3	LOS C	0.0	0.0	0.90	0.90	178.2	200.0	1.12
North: Road 1											
P3	Full	32	24.3	LOS C	0.0	0.0	0.90	0.90	178.2	200.0	1.12
West: Road 7											
P4	Full	32	24.3	LOS C	0.0	0.0	0.90	0.90	178.2	200.0	1.12
All Pedestrians		126	24.3	LOS C	0.0	0.0	0.90	0.90	178.2	200.0	1.12

Level of Service (LOS) Method: SIDRA Pedestrian LOS Method (Based on Average Delay)

Pedestrian movement LOS values are based on average delay per pedestrian movement.

Intersection LOS value for Pedestrians is based on average delay for all pedestrian movements.

SIDRA INTERSECTION 9.1 | Copyright © 2000-2024 Akcelik and Associates Pty Ltd | sidrasolutions.com

Organisation: AJW | Licence: NETWORK / 1PC | Processed: Friday, 27 March 2026 5:53:41 pm

Project: C:\Users\annaj\OneDrive\AW Consulting\Projects\Boffa Miskell Jobs\Wairakei South\ITA Work Feb 2026\Final SIDRA Modelling\Third Round Base Sidra File\2048_TTHM 10B Mitigated.sip9

MOVEMENT SUMMARY

Site: 10013a [10013_AM (Site Folder: General)]

Output produced by SIDRA INTERSECTION Version: 9.1.6.228

Network: N101
[2048_Opt10B_AM (Network Folder: General)]

Site Category: (None)
Roundabout

Vehicle Movement Performance															
Mov ID	Turn	Mov Class	Demand Flows		Arrival Flows		Deg. Satn	Aver. Delay	Level of Service	Aver. Back Of Queue		Prop. Que	Eff. Stop Rate	Aver. No. of Cycles	Aver. Speed
			[Total HV]	%	[Total HV]	%	v/c	sec		[Veh. veh	Dist]				km/h
South: Road 4															
1	L2	All MCs	216	5.9	216	5.9	0.343	4.1	LOS A	0.9	7.0	0.50	0.52	0.50	41.4
2	T1	All MCs	52	5.9	52	5.9	0.343	3.9	LOS A	0.9	7.0	0.50	0.52	0.50	43.6
3	R2	All MCs	125	5.9	125	5.9	0.343	8.9	LOS A	0.9	7.0	0.50	0.52	0.50	41.4
Approach			393	5.9	393	5.9	0.343	5.6	LOS A	0.9	7.0	0.50	0.52	0.50	41.8
East: Bell Road															
4	L2	All MCs	66	5.9	66	5.9	0.186	5.0	LOS A	0.4	2.7	0.45	0.52	0.45	45.5
5	T1	All MCs	108	5.9	108	5.9	0.186	4.8	LOS A	0.4	2.7	0.45	0.52	0.45	43.4
6	R2	All MCs	3	5.9	3	5.9	0.186	9.8	LOS A	0.4	2.7	0.45	0.52	0.45	44.0
Approach			178	5.9	177	5.9	0.186	5.0	LOS A	0.4	2.7	0.45	0.52	0.45	44.4
North: Road 4															
7	L2	All MCs	1	5.9	1	5.9	0.183	6.3	LOS A	0.4	3.3	0.69	0.69	0.69	33.1
8	T1	All MCs	31	5.9	31	5.9	0.183	6.1	LOS A	0.4	3.3	0.69	0.69	0.69	40.8
9	R2	All MCs	116	5.9	116	5.9	0.183	11.0	LOS B	0.4	3.3	0.69	0.69	0.69	33.1
Approach			147	5.9	147	5.9	0.183	10.0	LOS A	0.4	3.3	0.69	0.69	0.69	35.7
West: Bell Road															
10	L2	All MCs	168	5.9	168	5.9	0.522	4.0	LOS A	1.7	12.8	0.55	0.53	0.55	48.3
11	T1	All MCs	198	5.9	198	5.9	0.522	3.8	LOS A	1.7	12.8	0.55	0.53	0.55	48.3
12	R2	All MCs	271	5.9	271	5.9	0.522	8.8	LOS A	1.7	12.8	0.55	0.53	0.55	48.2
Approach			637	5.9	637	5.9	0.522	6.0	LOS A	1.7	12.8	0.55	0.53	0.55	48.3
All Vehicles			1355	5.9	1354	5.9	0.522	6.2	LOS A	1.7	12.8	0.54	0.54	0.54	47.1

Site Level of Service (LOS) Method: Delay (SIDRA). Site LOS Method is specified in the Network Data dialog (Override Site Data tab).

Roundabout LOS Method: SIDRA Roundabout LOS.

Vehicle movement LOS values are based on average delay per movement.

Intersection and Approach LOS values are based on average delay for all vehicle movements.

Roundabout Capacity Model: SIDRA Standard.

Delay Model: SIDRA Standard (Control Delay: Geometric Delay is included).

Queue Model: SIDRA queue estimation methods are used for Back of Queue and Queue at Start of Gap.

Gap-Acceptance Capacity Formula: SIDRA Standard (Akçelik M3D).

HV (%) values are calculated for All Movement Classes of All Heavy Vehicle Model Designation.

Arrival Flows used in performance calculations are adjusted to include any Initial Queued Demand and Upstream Capacity Constraint effects.

SIDRA INTERSECTION 9.1 | Copyright © 2000-2024 Akcelik and Associates Pty Ltd | sidrasolutions.com

Organisation: AJW | Licence: NETWORK / 1PC | Processed: Friday, 27 March 2026 5:53:41 pm

Project: C:\Users\lannaj\OneDrive\AW Consulting\Projects\Boffa Miskell Jobs\Wairakei South\ITA Work Feb 2026\Final SIDRA Modelling\Third Round Base Sidra File\2048_TTHM 10B Mitigated.sip9

MOVEMENT SUMMARY

 Site: 101 [1348 Bell Rd Parton Rd AM (Site Folder: General)]

Output produced by SIDRA INTERSECTION Version: 9.1.6.228

 Network: N101
[2048_Opt10B_AM (Network Folder: General)]

New Site
Site Category: (None)
Stop (Two-Way)

Vehicle Movement Performance															
Mov ID	Turn	Mov Class	Demand Flows		Arrival Flows		Deg. Satn	Aver. Delay	Level of Service	Aver. Back Of Queue	Prop. Que	Eff. Stop Rate	Aver. No. of Cycles	Aver. Speed	
			[Total HV] veh/h	%	[Total HV] veh/h	%									v/c
East: Bell Road															
5	T1	All MCs	322	5.3	322	5.3	0.171	0.1	LOS A	0.0	0.0	0.00	0.00	0.00	99.9
6	R2	All MCs	123	5.3	123	5.3	0.128	10.5	LOS B	0.2	1.6	0.56	0.77	0.56	87.6
Approach			445	5.3	445	5.3	0.171	3.0	NA	0.2	1.6	0.15	0.21	0.15	95.7
North: Parton Road															
7	L2	All MCs	181	5.3	181	5.3	0.215	12.6	LOS B	0.4	2.7	0.53	0.93	0.53	62.3
9	R2	All MCs	176	5.3	176	5.3	0.288	15.1	LOS C	0.5	3.4	0.67	1.03	0.78	57.8
Approach			357	5.3	357	5.3	0.288	13.9	LOS B	0.5	3.4	0.60	0.98	0.66	60.0
West: Bell Road															
10	L2	All MCs	101	5.3	101	5.3	0.296	8.0	LOS A	0.0	0.0	0.00	0.12	0.00	84.2
11	T1	All MCs	452	5.3	452	5.3	0.296	0.0	LOS A	0.0	0.0	0.00	0.12	0.00	94.4
Approach			553	5.3	553	5.3	0.296	1.5	NA	0.0	0.0	0.00	0.12	0.00	91.4
All Vehicles			1355	5.3	1354	5.3	0.296	5.2	NA	0.5	3.4	0.21	0.38	0.22	89.7

Site Level of Service (LOS) Method: Delay (SIDRA). Site LOS Method is specified in the Network Data dialog (Override Site Data tab).

Vehicle movement LOS values are based on average delay per movement.

Minor Road Approach LOS values are based on average delay for all vehicle movements.

NA (TWSC): Level of Service is not defined for major road approaches or the intersection as a whole for Two-Way Sign Control (HCM LOS rule).

Two-Way Sign Control Capacity Model: SIDRA Standard.

Delay Model: SIDRA Standard (Control Delay: Geometric Delay is included).

Queue Model: SIDRA queue estimation methods are used for Back of Queue and Queue at Start of Gap.

Gap-Acceptance Capacity Formula: SIDRA Standard (Akçelik M3D).

HV (%) values are calculated for All Movement Classes of All Heavy Vehicle Model Designation.

Arrival Flows used in performance calculations are adjusted to include any Initial Queued Demand and Upstream Capacity Constraint effects.

SIDRA INTERSECTION 9.1 | Copyright © 2000-2024 Akcelik and Associates Pty Ltd | sidrasolutions.com

Organisation: AJW | Licence: NETWORK / 1PC | Processed: Friday, 27 March 2026 5:53:41 pm

Project: C:\Users\anna\OneDrive\AW Consulting\Projects\Bofa Miskell Jobs\Wairakei South\ITA Work Feb 2026\Final SIDRA Modelling\Third Round Base Sidra File\2048_TTHM 10B Mitigated.sip9

SITE LAYOUT

 Site: 101 [1348 Bell Rd Parton Rd AM (Site Folder: General)]

New Site
Site Category: (None)
Stop (Two-Way)

Layout pictures are schematic functional drawings reflecting input data. They are not design drawings.

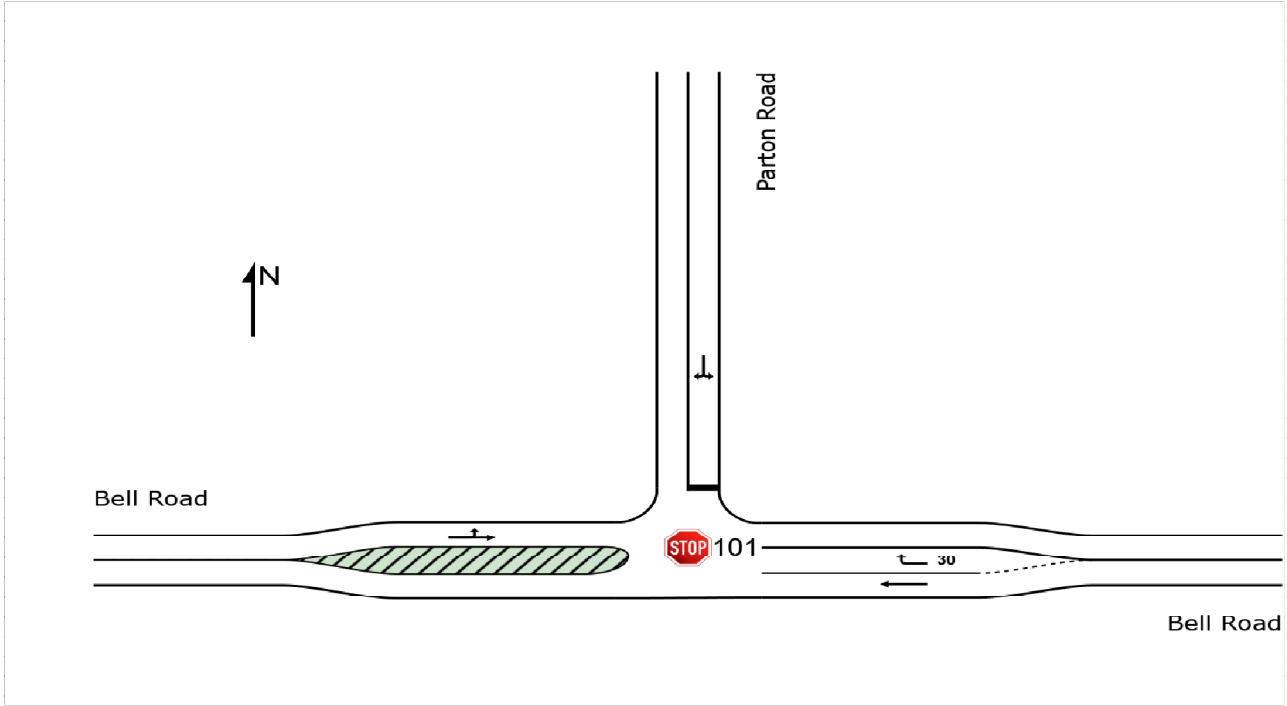

SIDRA INTERSECTION 9.1 | Copyright © 2000-2024 Kcelik and Associates Pty Ltd | sidrasolutions.com

Organisation: BOFFA MISKELL | Licence: NETWORK / 1PC | Created: Thursday, 23 April 2026 10:12:00 am
Project: U:\2025\BM250088_BSa_Wairakei_South_Masterplan\Documents\Transport\Modelling\Sidra Network\260328 Sidra Models for ITA from Anna\2048_TTHM 10B Mitigated_v1.sip9

MOVEMENT SUMMARY

 Site: 101 [1348 Bell Rd Parton Rd AM (Site Folder: General)]

Output produced by SIDRA INTERSECTION Version: 9.1.6.228

 Network: N101
[2048_Opt10B_AM (Network Folder: General)]

New Site
Site Category: (None)
Stop (Two-Way)

Vehicle Movement Performance															
Mov ID	Turn	Mov Class	Demand Flows		Arrival Flows		Deg. Satn	Aver. Delay	Level of Service	Aver. Back of Queue	Prop. Que	Eff. Stop Rate	Aver. No. of Cycles	Aver. Speed	
			[Total HV] veh/h	%	[Total HV] veh/h	%									v/c
East: Bell Road															
5	T1	All MCs	322	5.3	322	5.3	0.171	0.1	LOS A	0.0	0.0	0.00	0.00	0.00	99.9
6	R2	All MCs	123	5.3	123	5.3	0.128	10.2	LOS B	0.2	1.6	0.56	0.78	0.56	87.7
Approach			445	5.3	445	5.3	0.171	2.9	NA	0.2	1.6	0.15	0.21	0.15	95.8
North: Parton Road															
7	L2	All MCs	181	5.3	181	5.3	0.503	14.7	LOS B	1.3	9.2	0.68	1.06	1.05	56.4
9	R2	All MCs	176	5.3	176	5.3	0.503	17.3	LOS C	1.3	9.2	0.68	1.06	1.05	56.4
Approach			357	5.3	357	5.3	0.503	16.0	LOS C	1.3	9.2	0.68	1.06	1.05	56.4
West: Bell Road															
10	L2	All MCs	101	5.3	101	5.3	0.296	8.0	LOS A	0.0	0.0	0.00	0.12	0.00	84.2
11	T1	All MCs	452	5.3	452	5.3	0.296	0.0	LOS A	0.0	0.0	0.00	0.12	0.00	94.4
Approach			553	5.3	553	5.3	0.296	1.5	NA	0.0	0.0	0.00	0.12	0.00	91.3
All Vehicles			1355	5.3	1354	5.3	0.503	5.8	NA	1.3	9.2	0.23	0.40	0.33	88.9

Site Level of Service (LOS) Method: Delay (SIDRA). Site LOS Method is specified in the Network Data dialog (Override Site Data tab).

Vehicle movement LOS values are based on average delay per movement.

Minor Road Approach LOS values are based on average delay for all vehicle movements.

NA (TWSC): Level of Service is not defined for major road approaches or the intersection as a whole for Two-Way Sign Control (HCM LOS rule).

Two-Way Sign Control Capacity Model: SIDRA Standard.

Delay Model: SIDRA Standard (Control Delay: Geometric Delay is included).

Queue Model: SIDRA queue estimation methods are used for Back of Queue and Queue at Start of Gap.

Gap-Acceptance Capacity Formula: SIDRA Standard (Akçelik M3D).

HV (%) values are calculated for All Movement Classes of All Heavy Vehicle Model Designation.

Arrival Flows used in performance calculations are adjusted to include any Initial Queued Demand and Upstream Capacity Constraint effects.

SIDRA INTERSECTION 9.1 | Copyright © 2000-2024 Akcelik and Associates Pty Ltd | sidrasolutions.com

Organisation: BOFFA MISKELL | Licence: NETWORK / 1PC | Processed: Saturday, 28 March 2026 3:19:54 pm

Project: U:\2025\BM250088_BSa_Wairakei_South_Masterplan\Documents\Transport\Modelling\Sidra Network\260328 Sidra Models for ITA from Anna\2048_TTHM 10B Mitigated_v1.sip9

MOVEMENT SUMMARY

Site: 101v [2140 Te Puke Hwy Bell Rd AM Signals (Site Folder: General)]

Output produced by SIDRA INTERSECTION Version: 9.1.6.228

Network: N101
[2048_Opt10B_AM (Network Folder: General)]

New Site

Site Category: (None)

Signals - EQUISAT (Fixed-Time/SCATS) Isolated Cycle Time = 50 seconds (Site Practical Cycle Time)

Vehicle Movement Performance															
Mov ID	Turn	Mov Class	Demand Flows		Arrival Flows		Deg. Satn	Aver. Delay	Level of Service	Aver. Back Of Queue	Prop. Que	Eff. Stop Rate	Aver. No. of Cycles	Aver. Speed	
			[Total HV] veh/h	%	[Total HV] veh/h	%									v/c
South: Te Puke Hwy															
2	T1	All MCs	551	6.4	551	6.4	0.474	5.6	LOS A	4.5	33.1	0.58	0.51	0.58	99.0
3	R2	All MCs	237	6.4	237	6.4	*0.741	32.3	LOS C	3.8	28.1	1.00	0.88	1.21	94.4
Approach			787	6.4	787	6.4	0.741	13.6	LOS B	4.5	33.1	0.70	0.62	0.77	97.6
East: Bell Road															
4	L2	All MCs	331	6.4	330	6.4	0.328	12.5	LOS B	2.1	15.2	0.56	0.75	0.56	96.8
6	R2	All MCs	169	6.4	169	6.4	*0.681	33.2	LOS C	2.7	19.9	1.00	0.85	1.16	52.0
Approach			500	6.4	500	6.4	0.681	19.5	LOS B	2.7	19.9	0.71	0.78	0.76	93.7
North: Te Puke Hwy															
7	L2	All MCs	314	6.4	314	6.4	0.262	10.9	LOS B	1.4	10.5	0.44	0.72	0.44	63.1
8	T1	All MCs	620	6.4	620	6.4	*0.694	16.7	LOS B	5.9	43.3	0.89	0.77	0.94	97.1
Approach			934	6.4	934	6.4	0.694	14.8	LOS B	5.9	43.3	0.74	0.75	0.77	96.3
All Vehicles			2221	6.4	2221	6.4	0.741	15.4	LOS B	5.9	43.3	0.72	0.71	0.77	96.3

Site Level of Service (LOS) Method: Delay (SIDRA). Site LOS Method is specified in the Network Data dialog (Override Site Data tab).

Vehicle movement LOS values are based on average delay per movement.

Intersection and Approach LOS values are based on average delay for all vehicle movements.

Delay Model: SIDRA Standard (Control Delay: Geometric Delay is included).

Queue Model: SIDRA queue estimation methods are used for Back of Queue and Queue at Start of Green.

Gap-Acceptance Capacity Formula: SIDRA Standard (Akçelik M3D).

HV (%) values are calculated for All Movement Classes of All Heavy Vehicle Model Designation.

Arrival Flows used in performance calculations are adjusted to include any Initial Queued Demand and Upstream Capacity Constraint effects.

* Critical Movement (Signal Timing)

SIDRA INTERSECTION 9.1 | Copyright © 2000-2024 Akcelik and Associates Pty Ltd | sidrasolutions.com

Organisation: AJW | Licence: NETWORK / 1PC | Processed: Friday, 27 March 2026 5:53:41 pm

Project: C:\Users\annaj\OneDrive\AW Consulting\Projects\Boffa Miskell Jobs\Wairakei South\ITA Work Feb 2026\Final SIDRA Modelling\Third Round Base Sidra File\2048_TTHM 10B Mitigated.sip9

CCG PHASING SUMMARY

Common Control Group: CCG1 [CCG_1]

Output produced by SIDRA INTERSECTION Version: 9.1.6.228

Network: N101
[2048_Opt10B_AM (Network Folder: General)]

EQUISAT (Fixed-Time/SCATS) Coordinated Cycle Time = 130 seconds (Network Optimum Cycle Time - Minimum Delay)

Timings based on settings in the Network Timing dialog
 Phase Times determined by the program
 Downstream lane blockage effects included in determining phase times
 Phase Sequence: CCG Phasing
 Input Phase Sequence: A, B, C, D
 Output Phase Sequence: A, B, C, D
 Reference Phase: Phase A
 Offset: 0 seconds (Program)

Phase Timing Summary (CCG)

Phase	A	B	C	D
Phase Change Time (sec)	0	44	65	97
Green Time (sec)	38	15	26	27
Phase Time (sec)	44	21	32	33
Phase Split	34%	16%	25%	25%
Phase Frequency (%)	100.0	100.0	100.0	100.0

See the Timing Analysis report for more detailed information including input values of Yellow Time and All-Red Time, and information on any adjustments to Intergreen Time, Phase Time and Green Time values in cases of Pedestrian Actuation, Minor Phase Actuation and Phase Frequency values (user-specified or implied) less than 100%.

Output Phase Sequence (CCG)

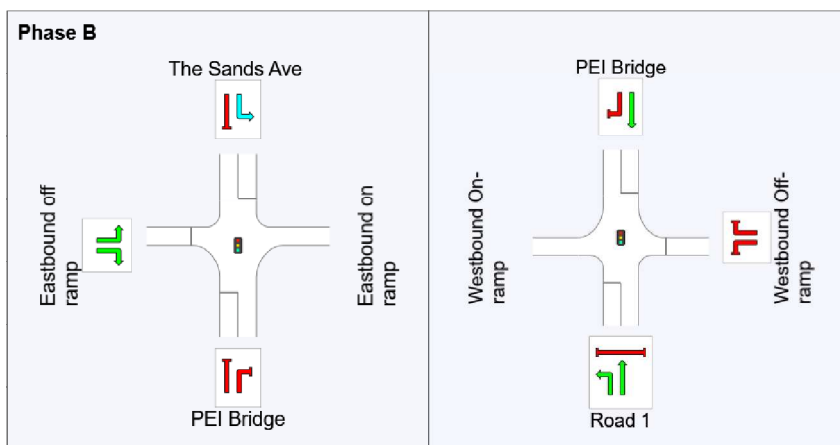
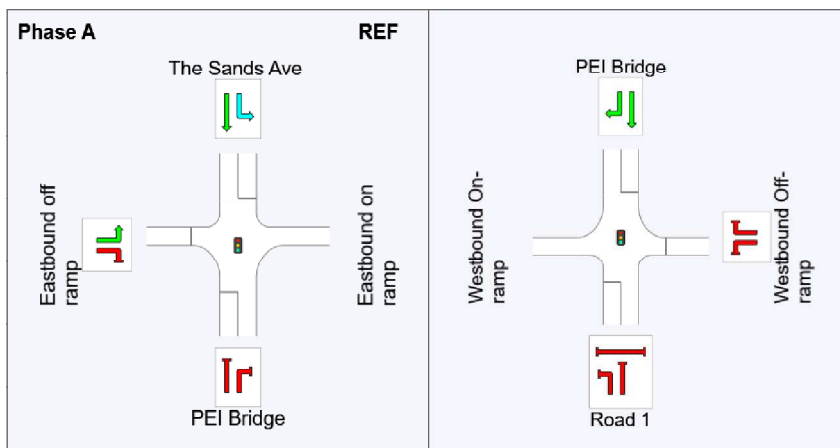

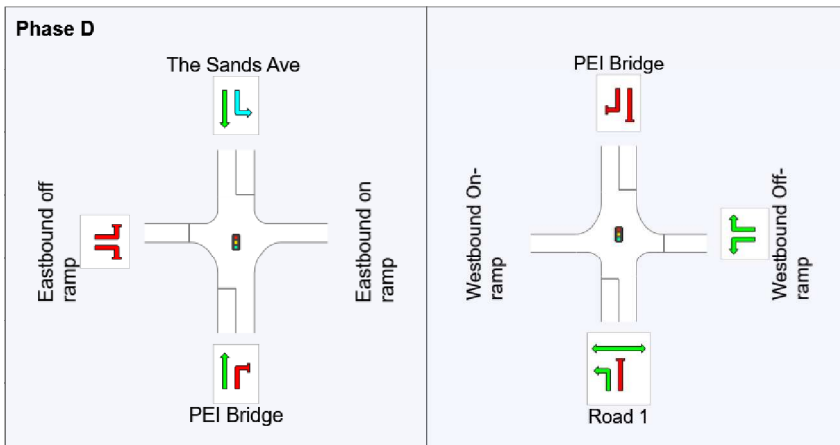
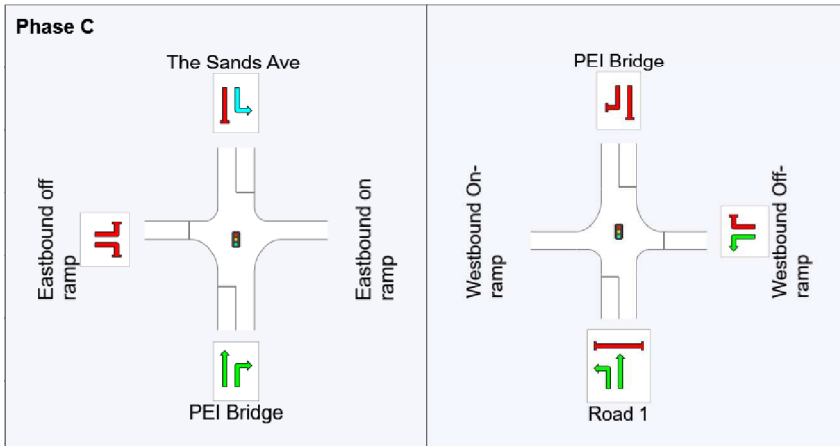

REF: Reference Phase
 VAR: Variable Phase

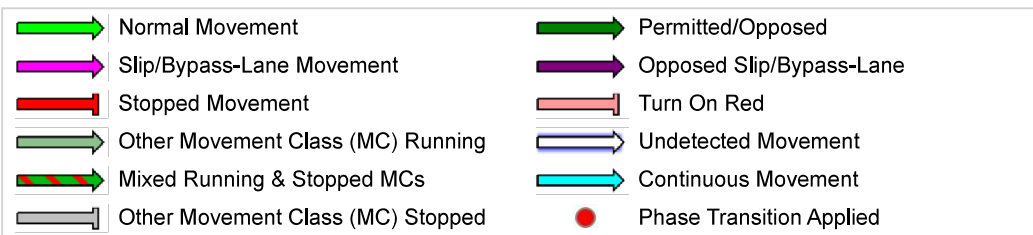

SIDRA INTERSECTION 9.1 | Copyright © 2000-2024 Akcelik and Associates Pty Ltd | sidrasolutions.com

Organisation: AJW | Licence: NETWORK / 1PC | Processed: Friday, 27 March 2026 5:53:41 pm

Project: C:\Users\annaj\OneDrive\AW Consulting\Projects\Boffa Miskell Jobs\Wairakei South\ITA Work Feb 2026\Final SIDRA Modelling\Third Round Base Sidra File\2048_TTHM 10B Mitigated.sip9

PHASING SUMMARY

Site: 2859a [2859 Boulv_TheSand_AM (Site Folder: General)]

Output produced by SIDRA INTERSECTION Version: 9.1.6.228

Network: N101
[2048_Opt10B_AM (Network Folder: General)]

Site Category: (None)

Signals - EQUISAT (Fixed-Time/SCATS) Coordinated Cycle Time = 130 seconds (Network Optimum Cycle Time - Minimum Delay)

Timings based on settings in the Network Timing dialog

Phase Times determined by the program

Downstream lane blockage effects included in determining phase times

Green Split Priority has been specified

Phase Sequence: DDO - Copy

Input Phase Sequence: A, B*, C*, D, D1*, E, F, F1*

Output Phase Sequence: A, B*, D, D1*, E, F, F1*

Reference Phase: Phase A

Offset: 50 seconds (Program)

(* Variable Phase)

Phase Timing Summary

Phase	A	B	D	D1	E	F	F1
Phase Change Time (sec)	54	75	103	115	129	11	43
Green Time (sec)	19	22	6	8	6	26	5
Phase Time (sec)	25	28	12	14	12	32	7
Phase Split	19%	22%	9%	11%	9%	25%	5%
Phase Frequency (%)	100.0	100.0	100.0	100.0	100.0	100.0	28.3 ³

See the Timing Analysis report for more detailed information including input values of Yellow Time and All-Red Time, and information on any adjustments to Intergreen Time, Phase Time and Green Time values in cases of Pedestrian Actuation, Minor Phase Actuation and Phase Frequency values (user-specified or implied) less than 100%.

³ Phase Frequency has been estimated from actuated movement probabilities.

Output Phase Sequence

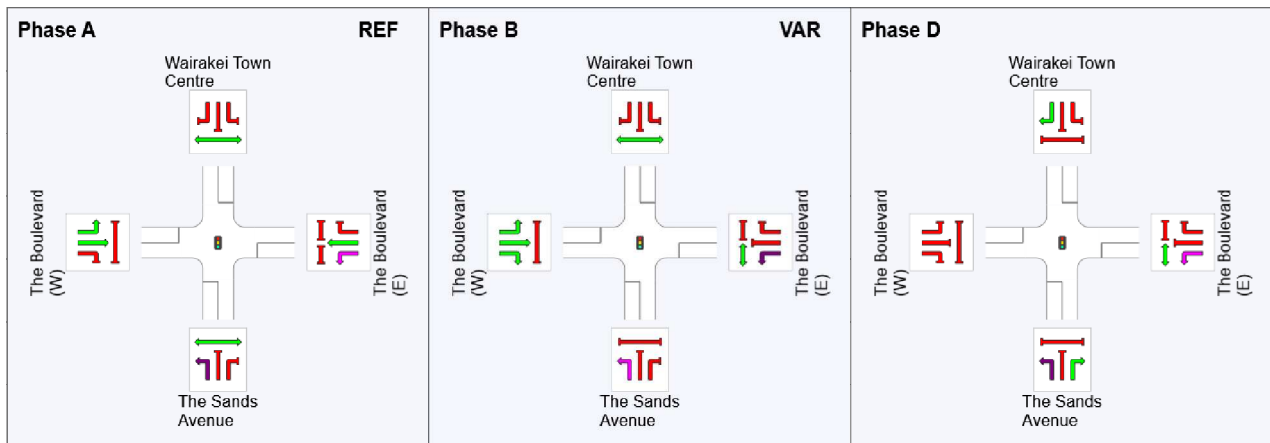

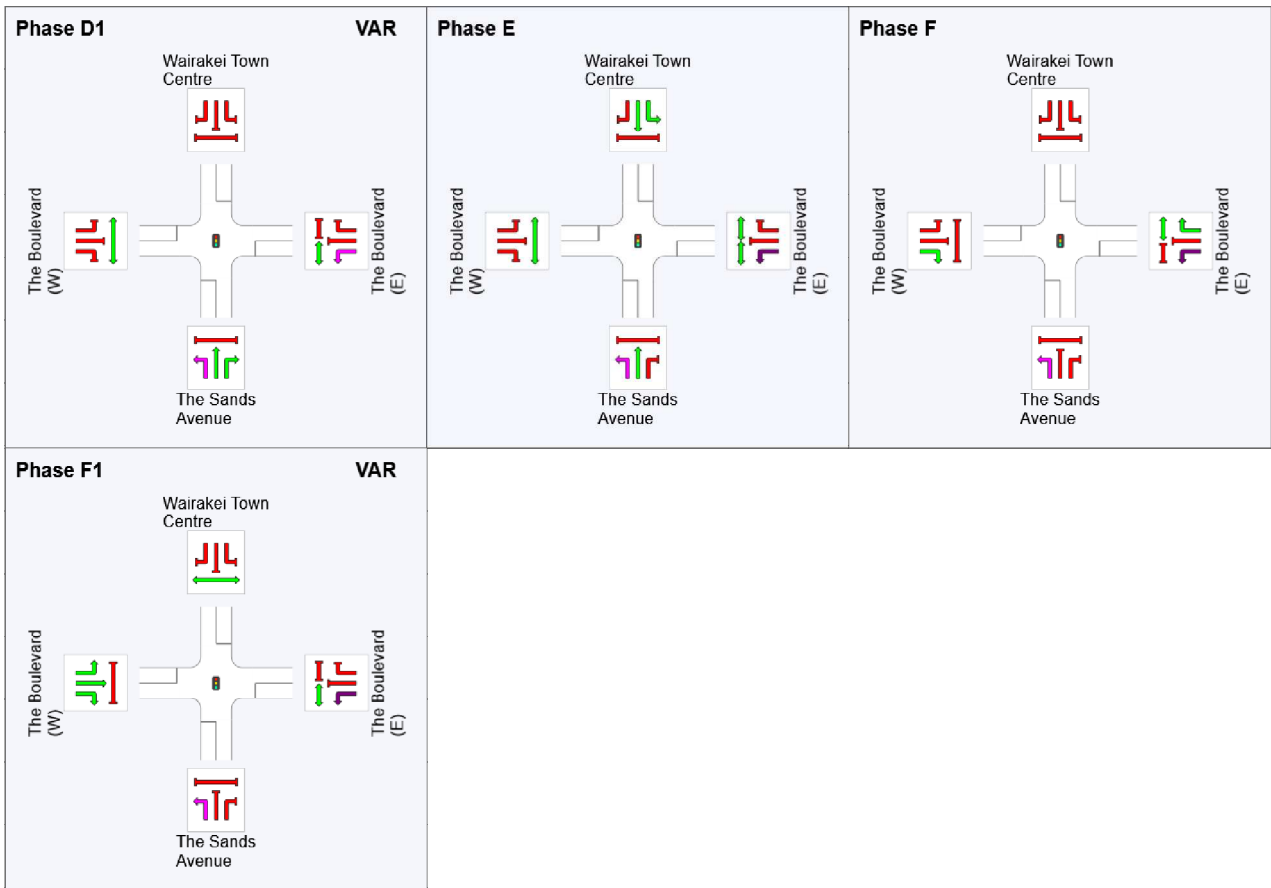

REF: Reference Phase
 VAR: Variable Phase



SIDRA INTERSECTION 9.1 | Copyright © 2000-2024 Akcelik and Associates Pty Ltd | sidrasolutions.com

Organisation: AJW | Licence: NETWORK / 1PC | Processed: Friday, 27 March 2026 5:53:41 pm

Project: C:\Users\anna\OneDrive\AW Consulting\Projects\Boffa Miskell Jobs\Wairakei South\ITA Work Feb 2026\Final SIDRA Modelling\Third Round Base Sidra File\2048_TTHM 10B Mitigated.sip9

PHASING SUMMARY

Site: 2860a [2860 The Sand_Bill Miller_AM (Site Folder: General)]

Output produced by SIDRA INTERSECTION Version: 9.1.6.228

Network: N101
[2048_Opt10B_AM (Network Folder: General)]

Site Category: (None)

Signals - EQUISAT (Fixed-Time/SCATS) Coordinated Cycle Time = 130 seconds (Network Optimum Cycle Time - Minimum Delay)

Timings based on settings in the Network Timing dialog

Phase Times determined by the program

Downstream lane blockage effects included in determining phase times

Green Split Priority has been specified

Phase Sequence: DDO - Copy

Input Phase Sequence: A, D, E, F

Output Phase Sequence: A, D, E, F

Reference Phase: Phase A

Offset: 98 seconds (Program)

Phase Timing Summary

Phase	A	D	E	F
Phase Change Time (sec)	98	51	63	85
Green Time (sec)	77	6	16	7
Phase Time (sec)	83	12	22	13
Phase Split	64%	9%	17%	10%
Phase Frequency (%)	100.0	100.0	100.0	100.0

See the Timing Analysis report for more detailed information including input values of Yellow Time and All-Red Time, and information on any adjustments to Intergreen Time, Phase Time and Green Time values in cases of Pedestrian Actuation, Minor Phase Actuation and Phase Frequency values (user-specified or implied) less than 100%.

Output Phase Sequence

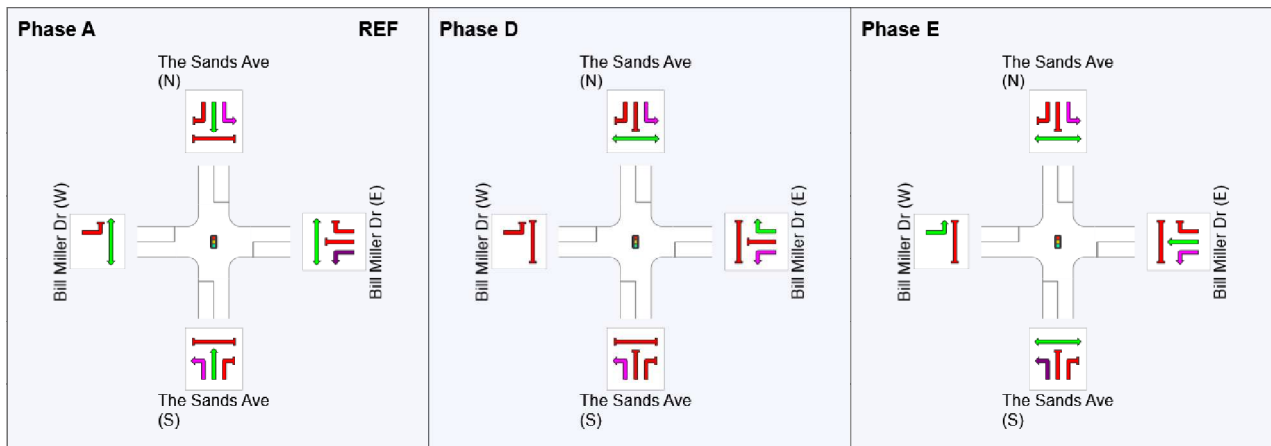

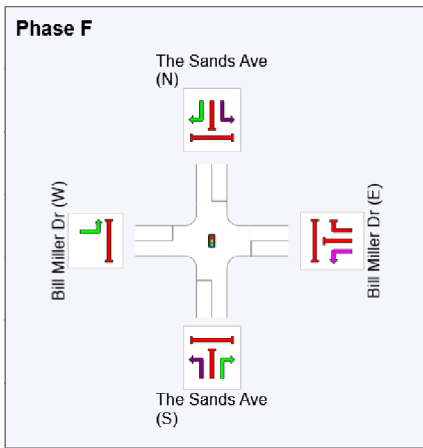

REF: Reference Phase
 VAR: Variable Phase

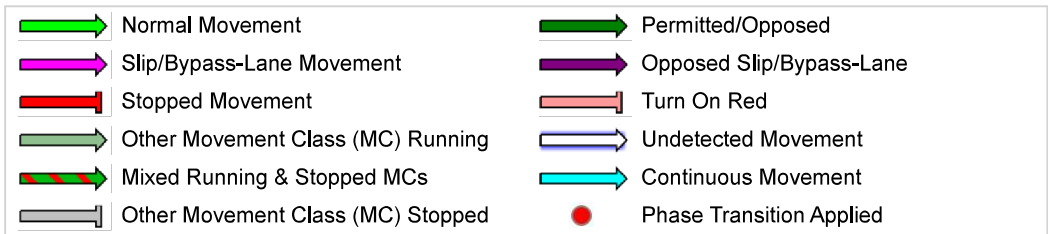

SIDRA INTERSECTION 9.1 | Copyright © 2000-2024 Kcelik and Associates Pty Ltd | sidrasolutions.com

Organisation: AJW | Licence: NETWORK / 1PC | Processed: Friday, 27 March 2026 5:53:41 pm

Project: C:\Users\annaj\OneDrive\AW Consulting\Projects\Boffa Miskell Jobs\Wairakei South\ITA Work Feb 2026\Final SIDRA Modelling\Third Round Base Sidra File\2048_TTHM 10B Mitigated.sip9

PHASING SUMMARY

Site: 2514a [2514 Sands_Te Okuroa_AM (Site Folder: General)]

Output produced by SIDRA INTERSECTION Version: 9.1.6.228

Network: N101
[2048_Opt10B_AM (Network Folder: General)]

Site Category: (None)

Signals - EQUISAT (Fixed-Time/SCATS) Coordinated Cycle Time = 130 seconds (Network Optimum Cycle Time - Minimum Delay)

Timings based on settings in the Network Timing dialog

Phase Times determined by the program

Downstream lane blockage effects not included in determining phase times

Phase Sequence: Variable Phasing

Input Phase Sequence: A, D, E, F

Output Phase Sequence: A, D, E, F

Reference Phase: Phase A

Offset: 86 seconds (Program)

Phase Timing Summary

Phase	A	D	E	F
Phase Change Time (sec)	86	2	25	51
Green Time (sec)	40	17	20	29
Phase Time (sec)	46	23	26	35
Phase Split	35%	18%	20%	27%
Phase Frequency (%)	100.0	100.0	100.0	100.0

See the Timing Analysis report for more detailed information including input values of Yellow Time and All-Red Time, and information on any adjustments to Intergreen Time, Phase Time and Green Time values in cases of Pedestrian Actuation, Minor Phase Actuation and Phase Frequency values (user-specified or implied) less than 100%.

Output Phase Sequence

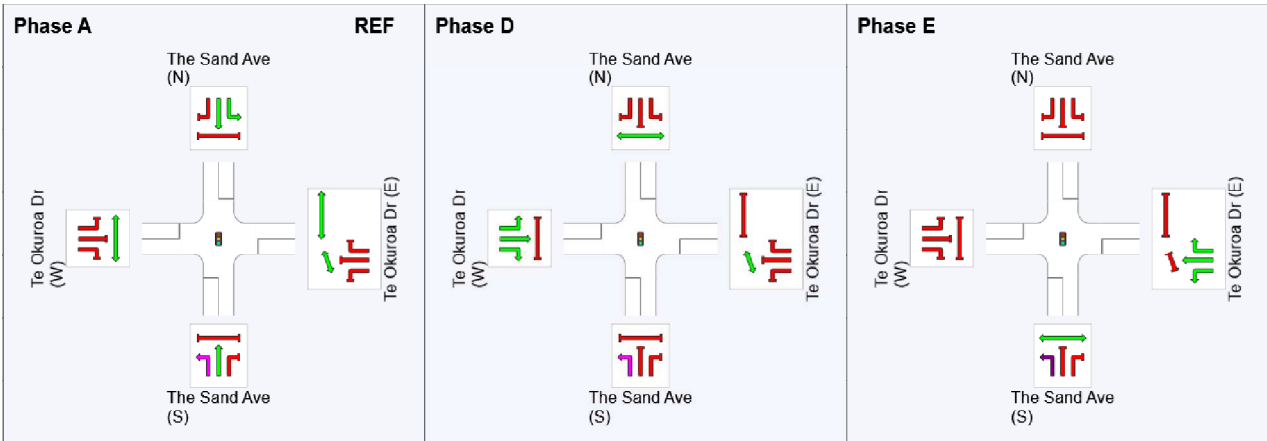

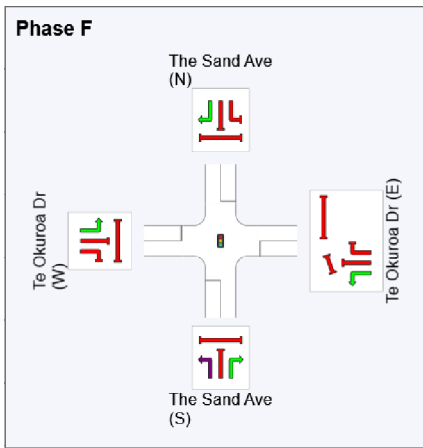

REF: Reference Phase

VAR: Variable Phase



SIDRA INTERSECTION 9.1 | Copyright © 2000-2024 Kcelik and Associates Pty Ltd | sidrasolutions.com

Organisation: AJW | Licence: NETWORK / 1PC | Processed: Friday, 27 March 2026 5:53:41 pm

Project: C:\Users\annaj\OneDrive\AW Consulting\Projects\Boffa Miskell Jobs\Wairakei South\ITA Work Feb 2026\Final SIDRA Modelling\Third Round Base Sidra File\2048_TTHM 10B Mitigated.sip9

PHASING SUMMARY

Site: 10003a [10003_AM (Site Folder: General)]

Output produced by SIDRA INTERSECTION Version: 9.1.6.228

Network: N101
[2048_Opt10B_AM (Network Folder: General)]

NA

Site Category: (None)

Signals - EQUISAT (Fixed-Time/SCATS) Isolated Cycle Time = 80 seconds (Site Practical Cycle Time)

Timings based on settings in the Site Phasing & Timing dialog

Phase Times determined by the program

Downstream lane blockage effects included in determining phase times

Green Split Priority has been specified

Phase Sequence: Four-Phase Split Phasing

Input Phase Sequence: A, B, C, D

Output Phase Sequence: A, B, C, D

Reference Phase: Phase A

Offset: 0 seconds (User)

Phase Timing Summary







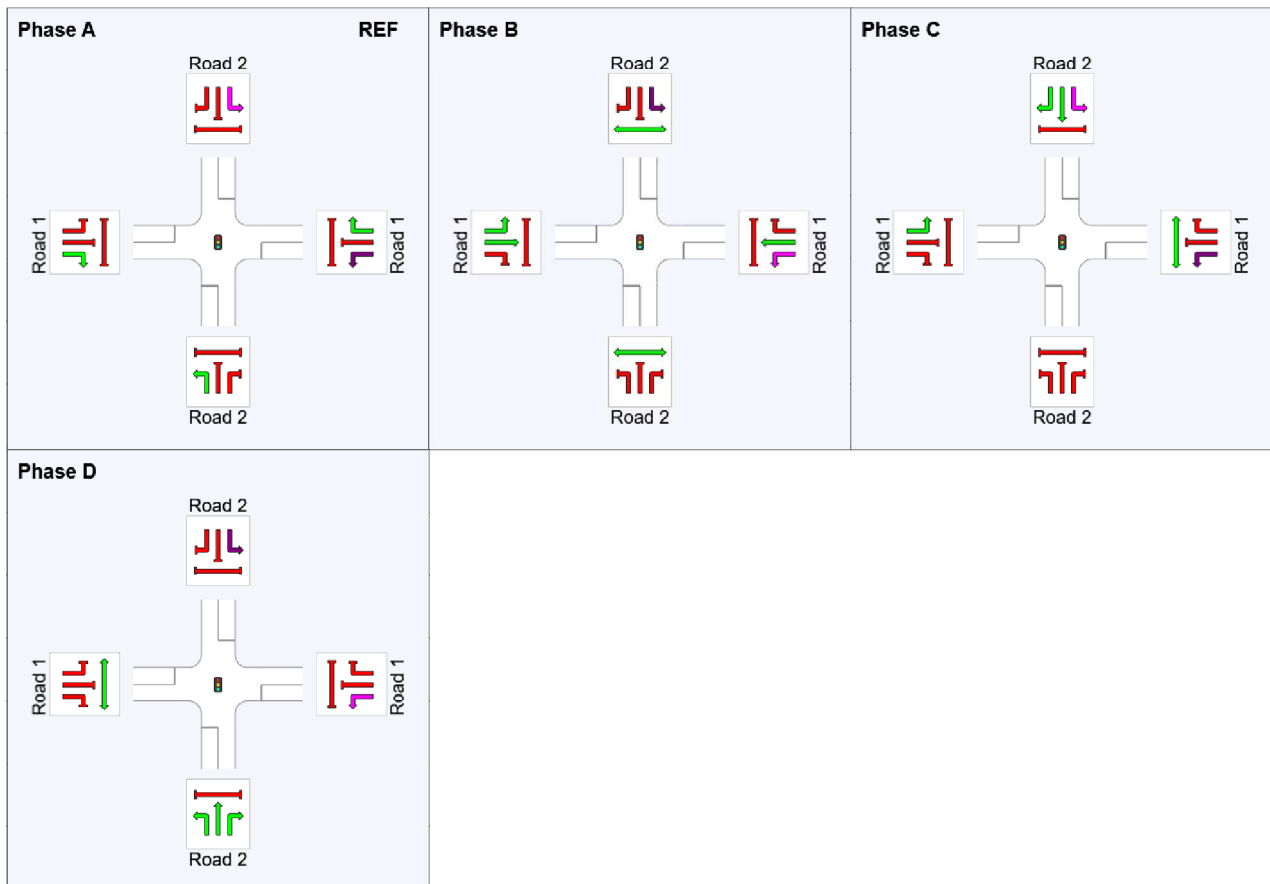



Phase	A	B	C	D
Phase Change Time (sec)	0	12	42	61
Green Time (sec)	6	24	13	13
Phase Time (sec)	12	30	19	19
Phase Split	15%	38%	24%	24%
Phase Frequency (%)	100.0	100.0	100.0	100.0

See the Timing Analysis report for more detailed information including input values of Yellow Time and All-Red Time, and information on any adjustments to Intergreen Time, Phase Time and Green Time values in cases of Pedestrian Actuation, Minor Phase Actuation and Phase Frequency values (user-specified or implied) less than 100%.

Output Phase Sequence



REF: Reference Phase
VAR: Variable Phase

	Normal Movement		Permitted/Opposed
	Slip/Bypass-Lane Movement		Opposed Slip/Bypass-Lane
	Stopped Movement		Turn On Red
	Other Movement Class (MC) Running		Undetected Movement
	Mixed Running & Stopped MCs		Continuous Movement
	Other Movement Class (MC) Stopped		Phase Transition Applied

SIDRA INTERSECTION 9.1 | Copyright © 2000-2024 Akcelik and Associates Pty Ltd | sidrasolutions.com

Organisation: AJW | Licence: NETWORK / 1PC | Processed: Friday, 27 March 2026 5:53:41 pm

Project: C:\Users\anna\OneDrive\AW Consulting\Projects\Boffa Miskell Jobs\Wairakei South\ITA Work Feb 2026\Final SIDRA Modelling\Third Round Base Sidra File\2048_TTHM 10B Mitigated.sip9

PHASING SUMMARY

Site: 10007a [10007_AM (Site Folder: General)]

Output produced by SIDRA INTERSECTION Version: 9.1.6.228

Network: N101
[2048_Opt10B_AM (Network Folder: General)]

NA

Site Category: (None)

Signals - EQUISAT (Fixed-Time/SCATS) Isolated Cycle Time = 70 seconds (Site Practical Cycle Time)

Timings based on settings in the Site Phasing & Timing dialog

Phase Times determined by the program

Downstream lane blockage effects included in determining phase times

Phase Sequence: Four-Phase Leading Right Turns

Input Phase Sequence: A, B, C, D

Output Phase Sequence: A, B, C, D

Reference Phase: Phase B

Offset: 0 seconds (User)

Phase Timing Summary







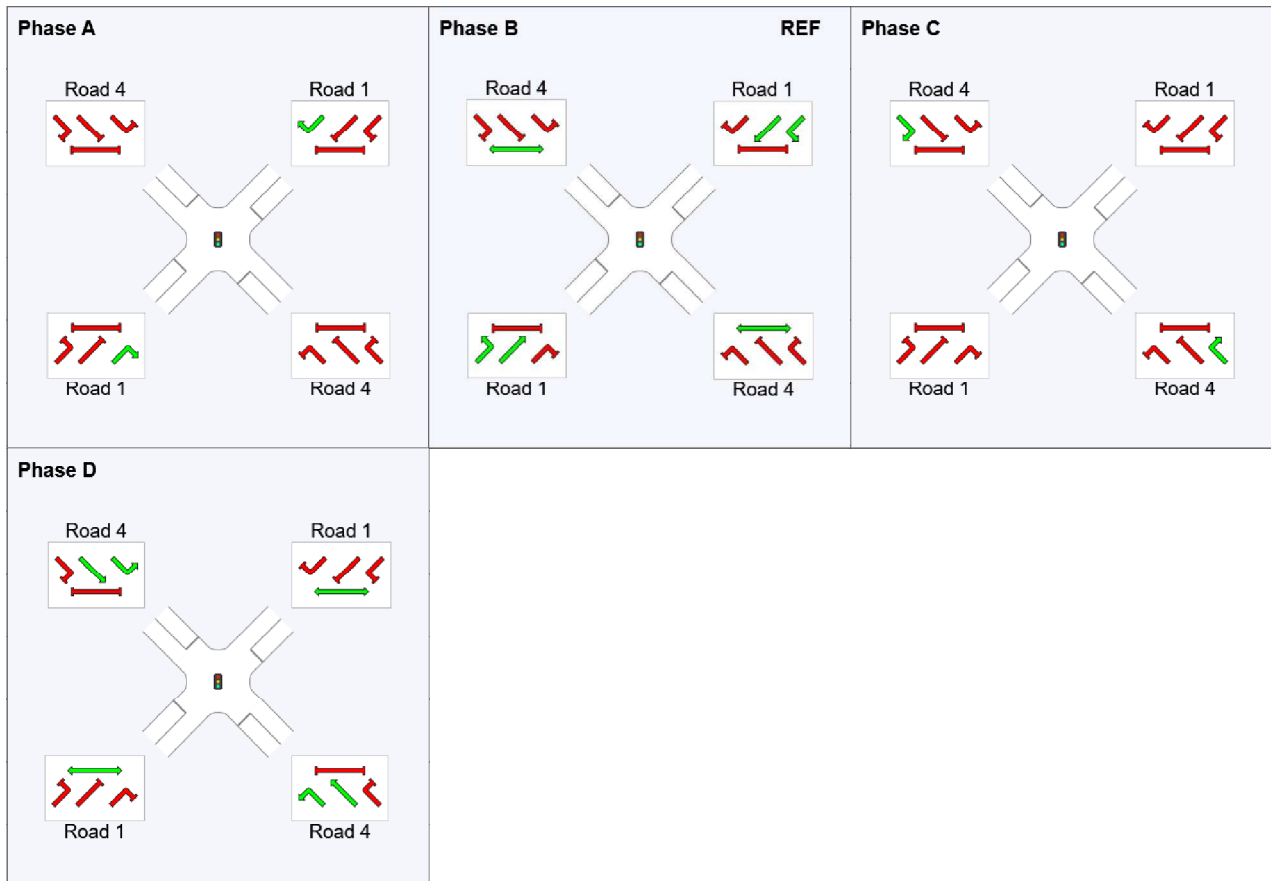





Phase	A	B	C	D
Phase Change Time (sec)	56	0	17	29
Green Time (sec)	8	11	6	21
Phase Time (sec)	14	17	12	27
Phase Split	20%	24%	17%	39%
Phase Frequency (%)	100.0	100.0	100.0	100.0

See the Timing Analysis report for more detailed information including input values of Yellow Time and All-Red Time, and information on any adjustments to Intergreen Time, Phase Time and Green Time values in cases of Pedestrian Actuation, Minor Phase Actuation and Phase Frequency values (user-specified or implied) less than 100%.

Output Phase Sequence



REF: Reference Phase
VAR: Variable Phase

	Normal Movement		Permitted/Opposed
	Slip/Bypass-Lane Movement		Opposed Slip/Bypass-Lane
	Stopped Movement		Turn On Red
	Other Movement Class (MC) Running		Undetected Movement
	Mixed Running & Stopped MCs		Continuous Movement
	Other Movement Class (MC) Stopped		Phase Transition Applied

PHASING SUMMARY

Site: 10008a [10008_AM (Site Folder: General)]

Output produced by SIDRA INTERSECTION Version: 9.1.6.228

Network: N101
[2048_Opt10B_AM (Network Folder: General)]

New Site

Site Category: (None)

Signals - EQUISAT (Fixed-Time/SCATS) Isolated Cycle Time = 70 seconds (Site Practical Cycle Time)

Timings based on settings in the Site Phasing & Timing dialog

Phase Times determined by the program

Downstream lane blockage effects included in determining phase times

Phase Sequence: Four-Phase Leading Right Turns

Input Phase Sequence: A, B, C, D

Output Phase Sequence: A, B, C, D

Reference Phase: Phase B

Offset: 0 seconds (User)

Phase Timing Summary



Phase	A	B	C	D
Phase Change Time (sec)	52	0	17	29
Green Time (sec)	12	11	6	17
Phase Time (sec)	18	17	12	23
Phase Split	26%	24%	17%	33%
Phase Frequency (%)	100.0	100.0	100.0	100.0

See the Timing Analysis report for more detailed information including input values of Yellow Time and All-Red Time, and information on any adjustments to Intergreen Time, Phase Time and Green Time values in cases of Pedestrian Actuation, Minor Phase Actuation and Phase Frequency values (user-specified or implied) less than 100%.

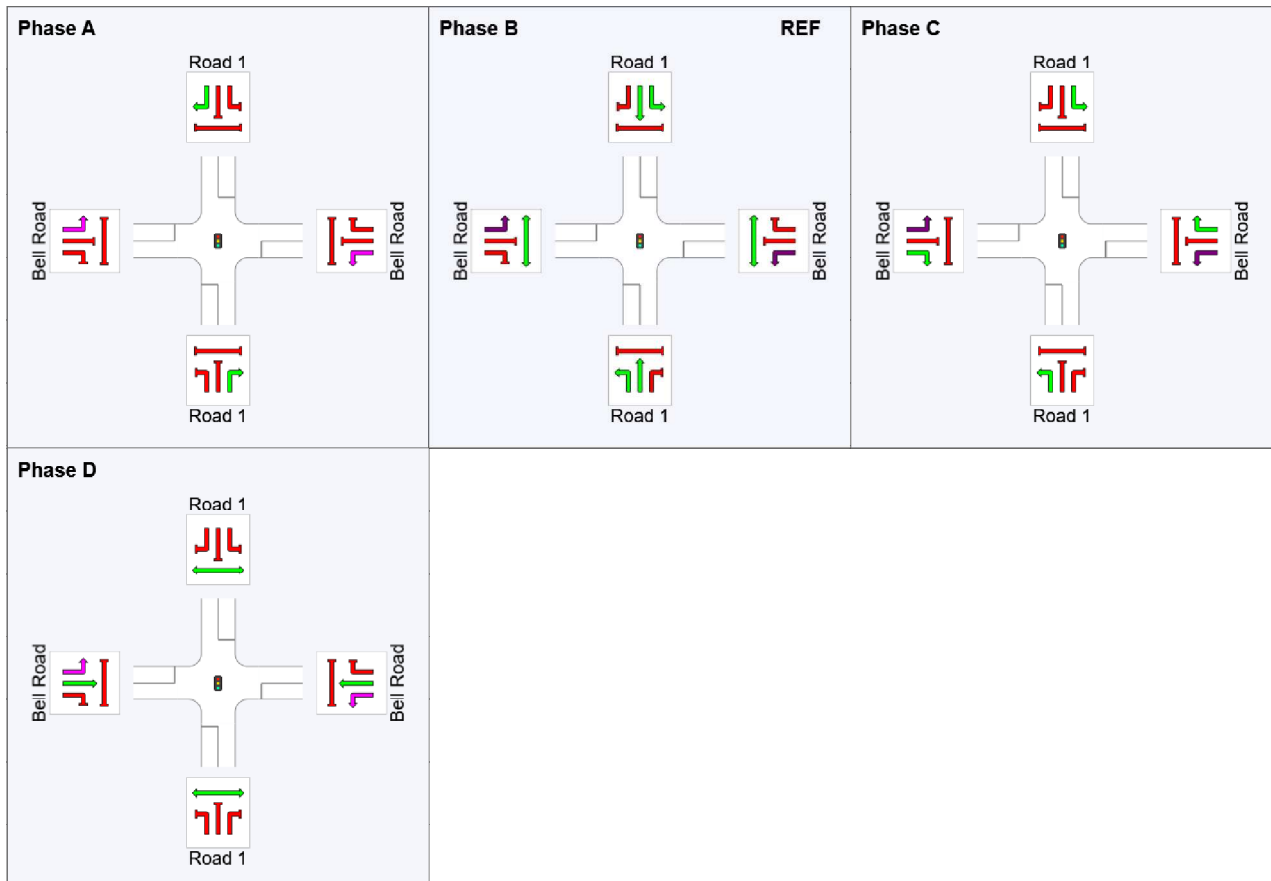
Output Phase Sequence



REF: Reference Phase
VAR: Variable Phase

	Normal Movement		Permitted/Opposed
	Slip/Bypass-Lane Movement		Opposed Slip/Bypass-Lane
	Stopped Movement		Turn On Red
	Other Movement Class (MC) Running		Undetected Movement
	Mixed Running & Stopped MCs		Continuous Movement
	Other Movement Class (MC) Stopped		Phase Transition Applied

SIDRA INTERSECTION 9.1 | Copyright © 2000-2024 Kcelik and Associates Pty Ltd | sidrasolutions.com

Organisation: AJW | Licence: NETWORK / 1PC | Processed: Friday, 27 March 2026 5:53:41 pm

Project: C:\Users\lannaj\OneDrive\AW Consulting\Projects\Boffa Miskell Jobs\Wairakei South\ITA Work Feb 2026\Final SIDRA Modelling\Third Round Base Sidra File\2048_TTHM 10B Mitigated.sip9

PHASING SUMMARY

Site: 10015a [10015_AM (Site Folder: General)]

Output produced by SIDRA INTERSECTION Version: 9.1.6.228

Network: N101
[2048_Opt10B_AM (Network Folder: General)]

New Site

Site Category: (None)

Signals - EQUISAT (Fixed-Time/SCATS) Isolated Cycle Time = 70 seconds (Site Practical Cycle Time)

Timings based on settings in the Site Phasing & Timing dialog

Phase Times determined by the program

Downstream lane blockage effects included in determining phase times

Phase Sequence: Four-Phase Leading Right Turns

Input Phase Sequence: A, B, C, D

Output Phase Sequence: A, B, C, D

Reference Phase: Phase B

Offset: 0 seconds (User)

Phase Timing Summary







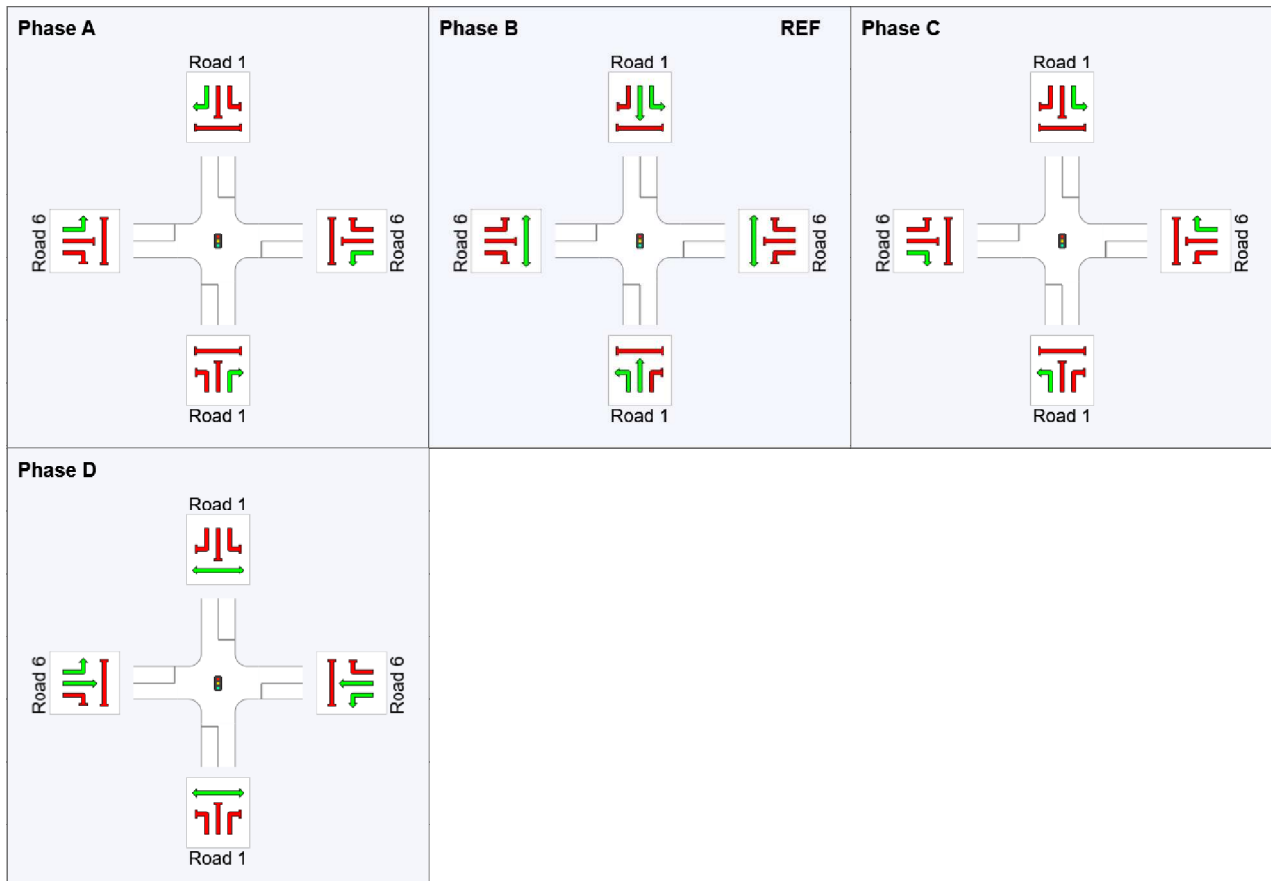



Phase	A	B	C	D
Phase Change Time (sec)	52	0	17	29
Green Time (sec)	12	11	6	17
Phase Time (sec)	18	17	12	23
Phase Split	26%	24%	17%	33%
Phase Frequency (%)	100.0	100.0	100.0	100.0

See the Timing Analysis report for more detailed information including input values of Yellow Time and All-Red Time, and information on any adjustments to Intergreen Time, Phase Time and Green Time values in cases of Pedestrian Actuation, Minor Phase Actuation and Phase Frequency values (user-specified or implied) less than 100%.

Output Phase Sequence



REF: Reference Phase
VAR: Variable Phase

	Normal Movement		Permitted/Opposed
	Slip/Bypass-Lane Movement		Opposed Slip/Bypass-Lane
	Stopped Movement		Turn On Red
	Other Movement Class (MC) Running		Undetected Movement
	Mixed Running & Stopped MCs		Continuous Movement
	Other Movement Class (MC) Stopped		Phase Transition Applied

PHASING SUMMARY

Site: 10016a [10016_AM (Site Folder: General)]

Output produced by SIDRA INTERSECTION Version: 9.1.6.228

Network: N101
[2048_Opt10B_AM (Network Folder: General)]

New Site

Site Category: (None)

Signals - EQUISAT (Fixed-Time/SCATS) Isolated Cycle Time = 60 seconds (Site Practical Cycle Time)

Timings based on settings in the Site Phasing & Timing dialog

Phase Times determined by the program

Downstream lane blockage effects included in determining phase times

Phase Sequence: Four-Phase Leading Right Turns

Input Phase Sequence: A, B, C, D

Output Phase Sequence: A, B, C, D

Reference Phase: Phase B

Offset: 0 seconds (User)

Phase Timing Summary







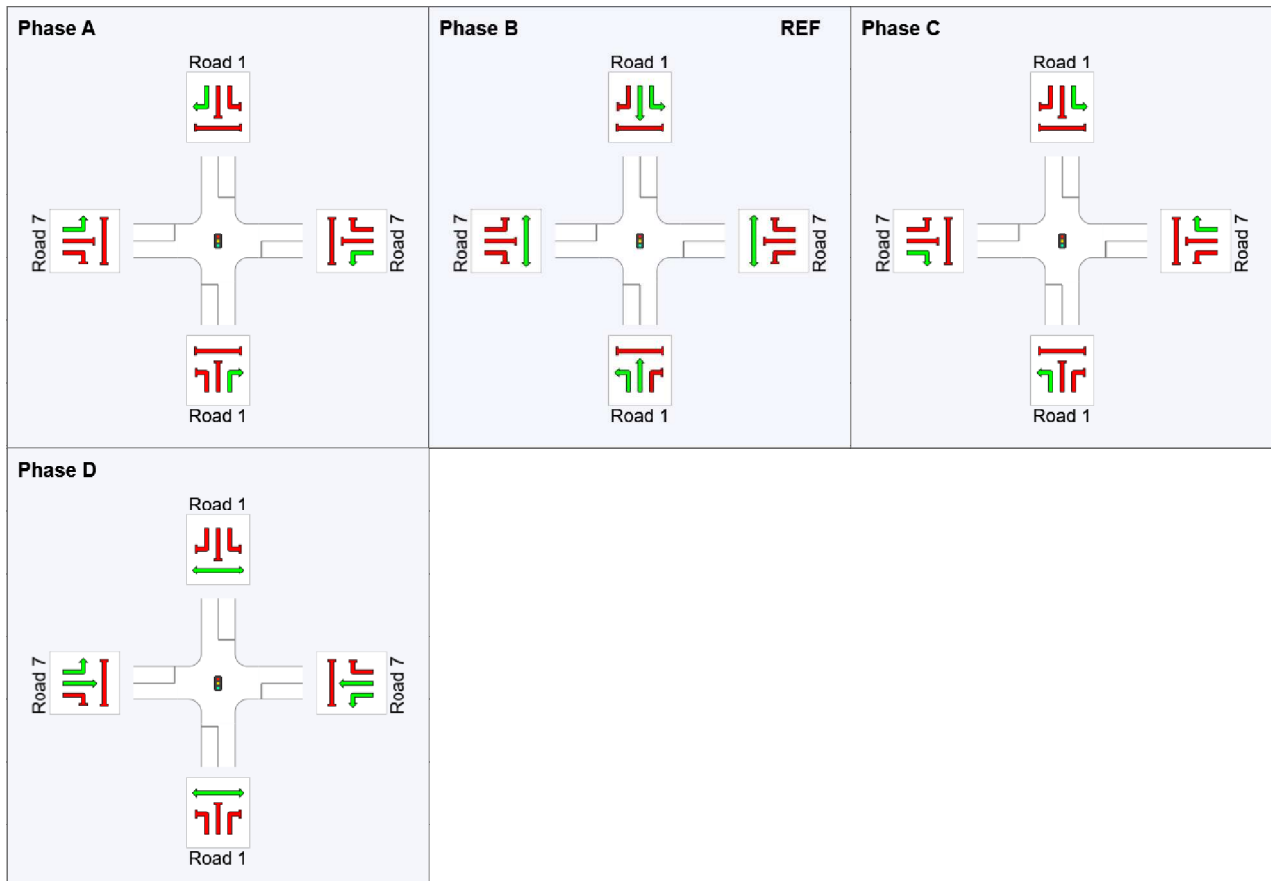





Phase	A	B	C	D
Phase Change Time (sec)	46	0	17	29
Green Time (sec)	8	11	6	11
Phase Time (sec)	14	17	12	17
Phase Split	23%	28%	20%	28%
Phase Frequency (%)	100.0	100.0	100.0	100.0

See the Timing Analysis report for more detailed information including input values of Yellow Time and All-Red Time, and information on any adjustments to Intergreen Time, Phase Time and Green Time values in cases of Pedestrian Actuation, Minor Phase Actuation and Phase Frequency values (user-specified or implied) less than 100%.

Output Phase Sequence



REF: Reference Phase
VAR: Variable Phase

	Normal Movement		Permitted/Opposed
	Slip/Bypass-Lane Movement		Opposed Slip/Bypass-Lane
	Stopped Movement		Turn On Red
	Other Movement Class (MC) Running		Undetected Movement
	Mixed Running & Stopped MCs		Continuous Movement
	Other Movement Class (MC) Stopped		Phase Transition Applied

PHASING SUMMARY

Site: 101v [2140 Te Puke Hwy Bell Rd AM Signals (Site Folder: General)]

Output produced by SIDRA INTERSECTION Version: 9.1.6.228

Network: N101
[2048_Opt10B_AM (Network Folder: General)]

New Site

Site Category: (None)

Signals - EQUISAT (Fixed-Time/SCATS) Isolated Cycle Time = 50 seconds (Site Practical Cycle Time)

Timings based on settings in the Site Phasing & Timing dialog

Phase Times determined by the program

Downstream lane blockage effects included in determining phase times

Phase Sequence: Convert Function Default

Input Phase Sequence: A, B, C

Output Phase Sequence: A, B, C

Reference Phase: Phase B

Offset: 0 seconds (User)

Phase Timing Summary

Phase	A	B	C
Phase Change Time (sec)	35	0	22
Green Time (sec)	9	16	7
Phase Time (sec)	15	22	13
Phase Split	30%	44%	26%
Phase Frequency (%)	100.0	100.0	100.0

See the Timing Analysis report for more detailed information including input values of Yellow Time and All-Red Time, and information on any adjustments to Intergreen Time, Phase Time and Green Time values in cases of Pedestrian Actuation, Minor Phase Actuation and Phase Frequency values (user-specified or implied) less than 100%.

Output Phase Sequence

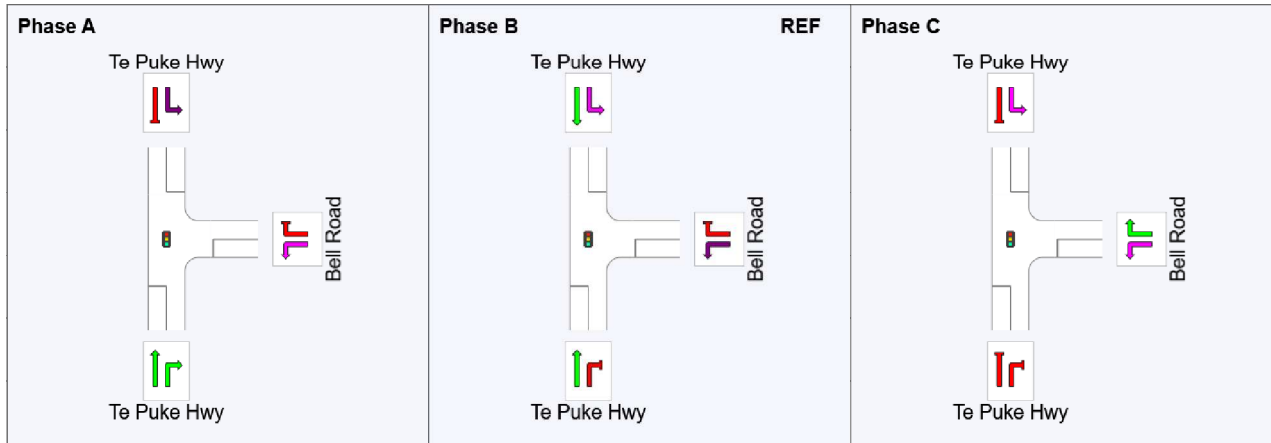

REF: Reference Phase

VAR: Variable Phase



SIGNAL OFFSETS

Network: N101 [2048_Opt10B_AM (Network Folder: General)]

Output produced by SIDRA INTERSECTION Version: 9.1.6.228

New Network

Network Category: (None)

Network Cycle Time = 130 seconds (Network Optimum Cycle Time - Minimum Delay)

SIGNAL OFFSETS

Offset Definition: Green Start

Reference Site / CCG: CCG1 [CCG_1]¹

Site ID	2440a ¹	2439a ¹	2514a	2860a	2859a
CCG ID (if applicable)	CCG1	CCG1	NA	NA	NA
Offset (sec)	0	0	86	98	50
Program / User	P	P	P	P	P
Reference Phase	A	A	A	A	A
Route ID	R101	R101	R101	R101	R101

¹ Reference Site / CCG as specified in the Network Timing dialog, Network Timing Data tab. This Site / CCG is included in the Route with the highest Offset Priority and is used in offset calculations.

ROUTE OFFSET RESULTS

Route ID: R101

Route Name: Sands NB

Offset Priority: 1

Offset Method: Start of Green (Leading)

Movement Class for Offset Calculation: Light Vehicles

Site ID	2440a ¹	2439a ¹	2514a	2860a	2859a
Reference Phase	A	A	A	A	A
Offset (sec)	0	0	86	98	50
Calculated offset used (Yes / No)	Yes	Yes	Yes	Yes	Yes
Approach	S	S	S	S	S
Turn	T1	T1	T1	T1	T1
Stopline Travel Distance (m)	370.4	129.5	267.8	156.5	161.6
Stopline Travel Time (sec)	28	11	21	12	13
Start Phase of Movement	B	C	A	A	D1
Relative Offset - Phase (sec)	0	50	21	12	17
Relative Offset - Movement (sec)	0	0	21	12	17
Phase Change Time (sec)	44	65	86	98	115
Displayed Green Start Time (sec)	50	71	92	104	121
Displayed Green Time (sec)	47	59	40	77	20
Effective Green Start Time (sec)	53	74	95	107	124
Effective Green Time (sec)	47	59	40	77	20
Green Time Ratio	0.362	0.454	0.308	0.592	0.154
% Arriving During Green	36.2	73.8	52.0	96.4	50.6
Platoon Ratio	1.000	1.626	1.691	1.627	3.288
Equivalent AT	3	5	5	5	6
Average Delay (sec)	53.8	12.7	32.5	1.0	30.7
% Back of Queue - Distance (m)	156.8	82.4	108.2	6.8	15.9
% Back of Queue - Vehicles	20.4	10.7	14.2	0.9	2.2
Effective Stop Rate	1.02	0.49	0.75	0.05	0.49
Proportion Queued	1.00	0.55	0.84	0.06	0.62

Route ID: R102

Route Name: Sands SB

Offset Priority: 2

Offset Method: Start of Green (Leading)

Movement Class for Offset Calculation: Light Vehicles

Site ID	2859a	2860a	2514a	2439a ¹	2440a ¹
Reference Phase	A	A	A	A	A
Offset (sec)	50	98	86	0	0
Calculated offset used (Yes / No)	No	No	No	No	No

Approach	N	N	N	N	N
Turn	T1	T1	T1	T1	T1
Stoptline Travel Distance (m)	0.0	170.2	149.1	274.6	129.0
Stoptline Travel Time (sec)	0	15	12	22	10
Start Phase of Movement	E	A	A	D	A
Relative Offset - Phase (sec)	0	99	118	11	11
Relative Offset - Movement (sec)	0	99	118	11	11
Phase Change Time (sec)	129	98	86	97	0
Displayed Green Start Time (sec)	5	104	92	103	6
Displayed Green Time (sec)	6	77	40	71	59
Effective Green Start Time (sec)	8	107	95	106	9
Effective Green Time (sec)	6	77	40	71	59
Green Time Ratio	0.046	0.592	0.308	0.546	0.454
% Arriving During Green	4.6	63.8	25.0	65.1	64.4
Platoon Ratio	1.000	1.077	0.811	1.191	1.420
Equivalent AT	3	4	2	4	4
Average Delay (sec)	74.9	68.4	122.3	41.9	19.3
% Back of Queue - Distance (m)	8.7	145.0	132.0	151.4	115.0
% Back of Queue - Vehicles	1.2	19.1	17.3	19.7	15.0
Effective Stop Rate	0.79	1.22	1.36	0.99	0.67
Proportion Queued	1.00	1.00	1.00	0.92	0.75

- 1 Reference Site / CCG as specified in the Network Timing dialog, Network Timing Data tab. This Site / CCG is included in the Route with the highest Offset Priority and is used in offset calculations.

SIDRA INTERSECTION 9.1 | Copyright © 2000-2024 Akcelik and Associates Pty Ltd | sidrasolutions.com

Organisation: AJW | Licence: NETWORK / 1PC | Processed: Friday, 27 March 2026 5:53:41 pm

Project: C:\Users\annaj\OneDrive\AW Consulting\Projects\Boffa Miskell Jobs\Wairakei South\ITA Work Feb 2026\Final SIDRA Modelling\Third Round Base Sidra File\2048_TTHM 10B Mitigated.sip9

SITE LAYOUT

 Site: 2122a [2122 TEL Te Puke Highway AM (Site Folder: General)]

New Site
Site Category: (None)
Roundabout

Layout pictures are schematic functional drawings reflecting input data. They are not design drawings.

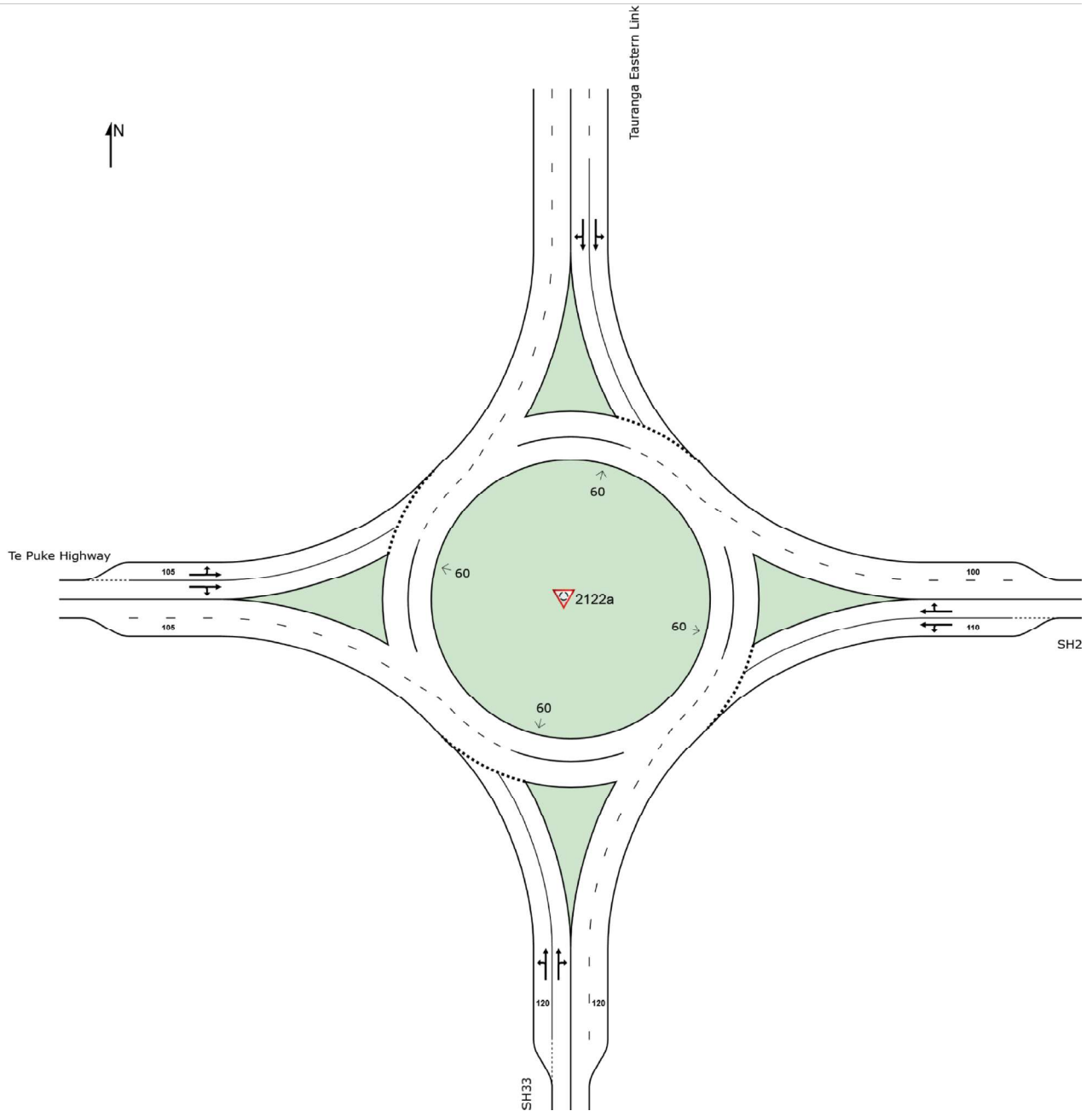

SIDRA INTERSECTION 9.1 | Copyright © 2000-2024 Kcelik and Associates Pty Ltd | sidrasolutions.com

Organisation: AJW | Licence: NETWORK / 1PC | Created: Friday, 27 March 2026 7:25:10 pm

Project: C:\Users\anna\OneDrive\AW Consulting\Projects\Boffa Miskell Jobs\Wairakei South\ITA Work Feb 2026\Final SIDRA Modelling\Third Round Base Sidra File\2048_TTHM 10B Mitigated.sip9

MOVEMENT SUMMARY

 Site: 2122a [2122 TEL Te Puke Highway AM (Site Folder: General)]

Output produced by SIDRA INTERSECTION Version: 9.1.6.228

New Site
 Site Category: (None)
 Roundabout

Vehicle Movement Performance															
Mov ID	Turn	Mov Class	Demand Flows		Arrival Flows		Deg. Satn	Aver. Delay	Level of Service	95% Back Of Queue		Prop. Que	Eff. Stop Rate	Aver. No. of Cycles	Aver. Speed
			[Total HV]	%	[Total HV]	%	v/c	sec		[Veh. veh	Dist] m				km/h
South: SH33															
1	L2	All MCs	118	18.8	118	18.8	0.431	6.0	LOS A	3.1	25.5	0.87	0.71	0.95	49.7
2	T1	All MCs	457	19.4	457	19.4	0.431	6.1	LOS A	3.1	25.5	0.86	0.76	0.96	45.9
3	R2	All MCs	1	0.0	1	0.0	0.431	14.0	LOS B	2.7	22.4	0.85	0.81	0.96	45.5
Approach			576	19.2	576	19.2	0.431	6.1	LOS A	3.1	25.5	0.86	0.75	0.95	48.9
East: SH2															
4	L2	All MCs	2	50.0	2	50.0	0.193	7.6	LOS A	1.0	8.2	0.75	0.64	0.75	46.3
5	T1	All MCs	116	16.4	116	16.4	0.193	5.2	LOS A	1.0	8.2	0.75	0.64	0.75	49.7
6	R2	All MCs	637	14.5	637	14.5	0.733	16.8	LOS B	8.4	66.5	0.97	1.06	1.44	41.1
Approach			755	14.9	755	14.9	0.733	15.0	LOS B	8.4	66.5	0.93	1.00	1.33	46.9
North: Tauranga Eastern Link															
7	L2	All MCs	777	8.5	777	8.5	0.663	3.5	LOS A	6.1	46.0	0.71	0.55	0.79	46.7
8	T1	All MCs	488	18.1	488	18.1	0.663	3.9	LOS A	6.1	47.1	0.74	0.63	0.85	45.7
9	R2	All MCs	244	16.8	244	16.8	0.663	10.8	LOS B	5.8	47.1	0.75	0.64	0.87	49.6
Approach			1509	13.0	1509	13.0	0.663	4.8	LOS A	6.1	47.1	0.73	0.59	0.82	48.7
West: Te Puke Highway															
10	L2	All MCs	57	44.4	57	44.4	0.304	7.5	LOS A	1.6	13.5	0.80	0.74	0.80	49.7
11	T1	All MCs	181	12.8	181	12.8	0.333	5.3	LOS A	2.1	16.8	0.82	0.73	0.82	49.6
12	R2	All MCs	188	16.2	188	16.2	0.333	11.1	LOS B	2.1	16.8	0.83	0.71	0.83	49.5
Approach			426	18.5	426	18.5	0.333	8.2	LOS A	2.1	16.8	0.82	0.72	0.82	49.6
All Vehicles			3266	15.2	3266	15.2	0.733	7.8	LOS A	8.4	66.5	0.81	0.73	0.96	48.8

Site Level of Service (LOS) Method: Delay (SIDRA). Site LOS Method is specified in the Parameter Settings dialog (Options tab).
 Roundabout LOS Method: SIDRA Roundabout LOS.
 Vehicle movement LOS values are based on average delay per movement.
 Intersection and Approach LOS values are based on average delay for all vehicle movements.
 Roundabout Capacity Model: SIDRA Standard.
 Delay Model: SIDRA Standard (Control Delay: Geometric Delay is included).
 Queue Model: SIDRA queue estimation methods are used for Back of Queue and Queue at Start of Gap.
 Gap-Acceptance Capacity Formula: SIDRA Standard (Akçelik M3D).
 HV (%) values are calculated for All Movement Classes of All Heavy Vehicle Model Designation.
 Arrival Flows used in performance calculations are adjusted to include any Initial Queued Demand and Upstream Capacity Constraint effects.

SITE LAYOUT

Site: 1335 [1335 Tara Rd Parton Rd RAB AM (Site Folder: General)]

New Site
Site Category: (None)
Roundabout

Layout pictures are schematic functional drawings reflecting input data. They are not design drawings.

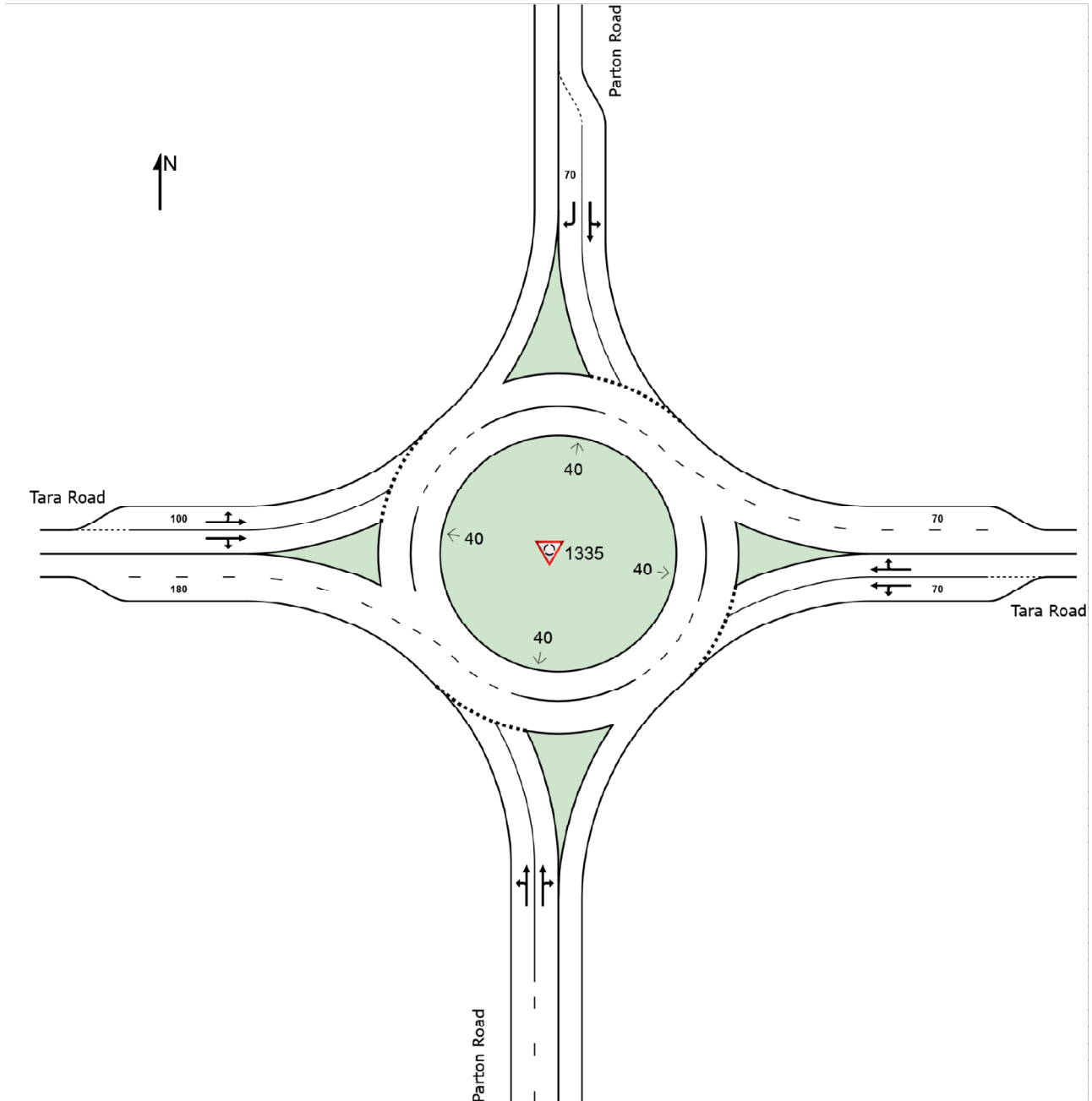

SIDRA INTERSECTION 9.1 | Copyright © 2000-2024 Akcelik and Associates Pty Ltd | sidrasolutions.com

Organisation: AJW | Licence: NETWORK / 1PC | Created: Friday, 27 March 2026 7:25:20 pm

Project: C:\Users\annaj\OneDrive\AW Consulting\Projects\Boffa Miskell Jobs\Wairakei South\ITA Work Feb 2026\Final SIDRA Modelling\Third Round Base Sidra File\2048_TTHM 10B Mitigated.sip9

MOVEMENT SUMMARY

 Site: 1335 [1335 Tara Rd Parton Rd RAB AM (Site Folder: General)]

Output produced by SIDRA INTERSECTION Version: 9.1.6.228

New Site
 Site Category: (None)
 Roundabout

Vehicle Movement Performance															
Mov ID	Turn	Mov Class	Demand Flows		Arrival Flows		Deg. Satn	Aver. Delay	Level of Service	95% Back Of Queue	Dist	Prop. Que	Eff. Stop Rate	Aver. No. of Cycles	Aver. Speed
			[Total HV]	%	[Total HV]	%	v/c	sec		[Veh. veh	m				km/h
South: Parton Road															
1	L2	All MCs	94	4.6	94	4.6	0.134	5.9	LOS A	0.6	4.3	0.66	0.68	0.66	49.6
2	T1	All MCs	38	4.6	38	4.6	0.141	3.7	LOS A	0.7	5.0	0.66	0.68	0.66	44.8
3	R2	All MCs	93	4.6	93	4.6	0.141	10.0	LOS B	0.7	5.0	0.66	0.68	0.66	44.3
Approach			224	4.6	224	4.6	0.141	7.2	LOS A	0.7	5.0	0.66	0.68	0.66	46.4
East: Tara Road															
4	L2	All MCs	175	4.6	175	4.6	0.442	3.3	LOS A	2.4	17.6	0.52	0.36	0.52	46.7
5	T1	All MCs	846	4.6	846	4.6	0.442	3.1	LOS A	2.4	17.6	0.53	0.36	0.53	50.3
6	R2	All MCs	7	4.6	7	4.6	0.442	9.1	LOS A	2.3	17.1	0.54	0.35	0.54	46.2
Approach			1028	4.6	1028	4.6	0.442	3.2	LOS A	2.4	17.6	0.53	0.36	0.53	49.6
North: Parton Road															
7	L2	All MCs	11	4.6	11	4.6	0.100	4.5	LOS A	0.4	3.0	0.52	0.45	0.52	46.7
8	T1	All MCs	72	4.6	72	4.6	0.100	3.6	LOS A	0.4	3.0	0.52	0.45	0.52	46.9
9	R2	All MCs	213	4.6	213	4.6	0.187	9.4	LOS A	0.9	6.4	0.53	0.67	0.53	46.4
Approach			295	4.6	295	4.6	0.187	7.8	LOS A	0.9	6.4	0.52	0.61	0.52	46.5
West: Tara Road															
10	L2	All MCs	107	4.6	107	4.6	0.176	3.8	LOS A	0.9	6.3	0.31	0.39	0.31	50.7
11	T1	All MCs	407	4.6	407	4.6	0.289	3.4	LOS A	1.7	12.2	0.32	0.41	0.32	50.4
12	R2	All MCs	104	4.6	104	4.6	0.289	9.9	LOS A	1.7	12.2	0.32	0.42	0.32	49.5
Approach			619	4.6	619	4.6	0.289	4.6	LOS A	1.7	12.2	0.32	0.41	0.32	50.3
All Vehicles			2166	4.6	2166	4.6	0.442	4.6	LOS A	2.4	17.6	0.48	0.44	0.48	49.0

Site Level of Service (LOS) Method: Delay (SIDRA). Site LOS Method is specified in the Parameter Settings dialog (Options tab).
 Roundabout LOS Method: SIDRA Roundabout LOS.
 Vehicle movement LOS values are based on average delay per movement.
 Intersection and Approach LOS values are based on average delay for all vehicle movements.
 Roundabout Capacity Model: SIDRA Standard.
 Delay Model: SIDRA Standard (Control Delay: Geometric Delay is included).
 Queue Model: SIDRA queue estimation methods are used for Back of Queue and Queue at Start of Gap.
 Gap-Acceptance Capacity Formula: SIDRA Standard (Akçelik M3D).
 HV (%) values are calculated for All Movement Classes of All Heavy Vehicle Model Designation.
 Arrival Flows used in performance calculations are adjusted to include any Initial Queued Demand and Upstream Capacity Constraint effects.

SIDRA Network and Intersection Outputs

2048 10B Mitigated PM

NETWORK LAYOUT

Network: N101 [2048_Opt10B_PM (Network Folder: General)]

New Network
 Network Category: (None)

Layout pictures are schematic functional drawings reflecting input data. They are not design drawings.

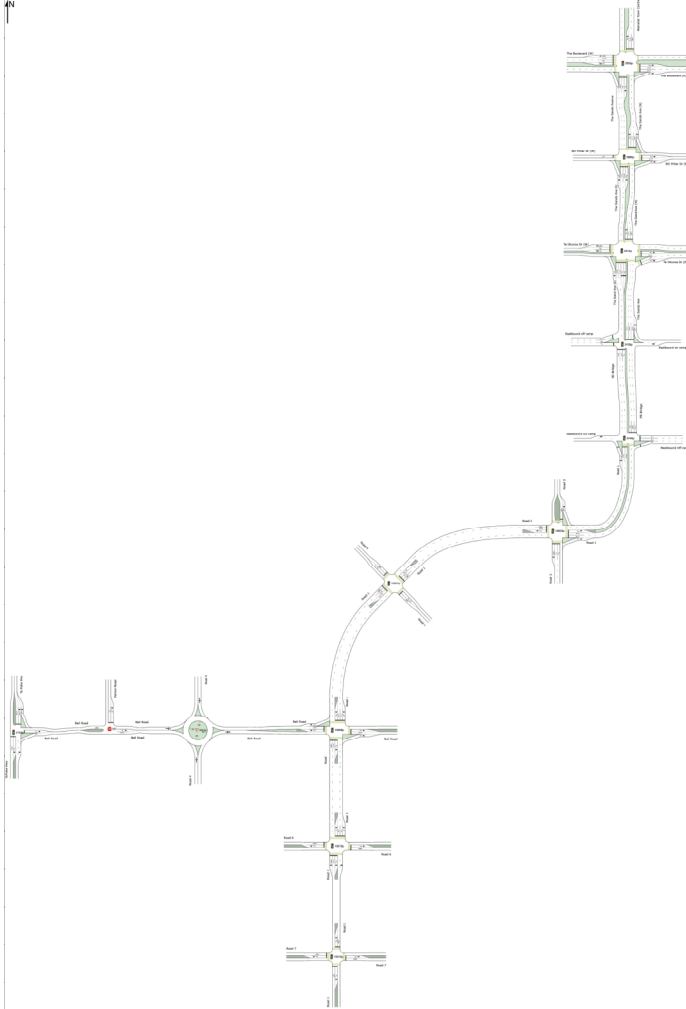

SITES IN NETWORK		
Site ID	CCG ID	Site Name
2859p	NA	2859 Boulv_TheSand_PM
2860p	NA	2860 The Sand_Bill Miller_PM
2514p	NA	2514 Sands_Te Okuroa_PM
2439p	CCG1	2439 Papamoia Eastern Int North_PM
2440p	CCG1	2440 Papamoia Eastern Int South_PM
10003p	NA	10003_PM
10007p	NA	10007_PM
10008p	NA	10008_PM
10015p	NA	10015_PM
10016p	NA	10016_PM
10013p	NA	10013_PM
101	NA	1348 Bell Rd Parton Rd PM
2140p	NA	2140 Te Puke Hwy Bell Rd PM Signals

APPROACH LEVEL OF SERVICE

Approach Level of Service

Network: N101 [2048_Opt10B_PM (Network Folder: General)]

Output produced by SIDRA INTERSECTION Version: 9.1.6.228

New Network

Network Category: (None)

Network Cycle Time = 130 seconds (Network Optimum Cycle Time - Minimum Delay)

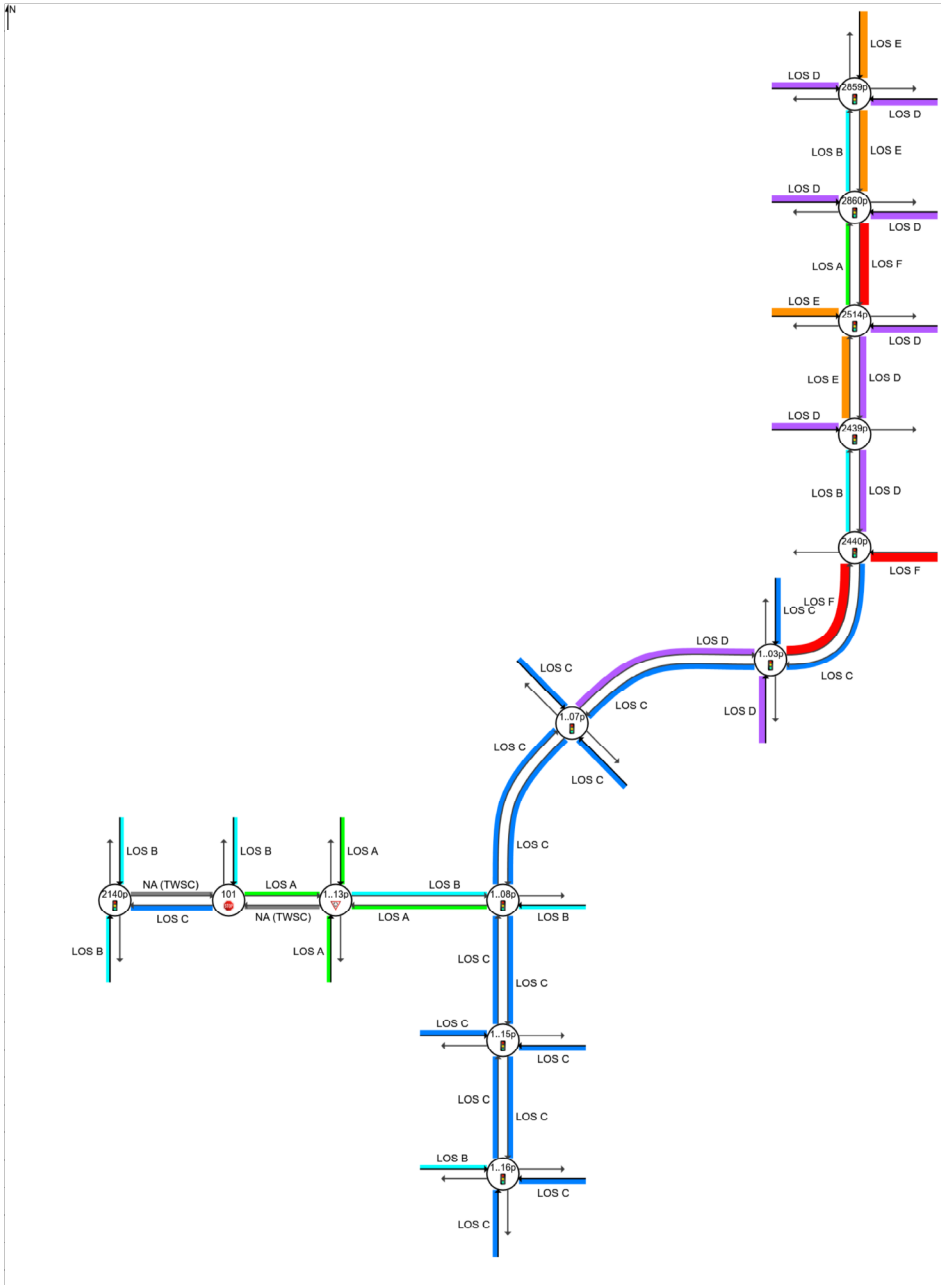

Colour code based on Level of Service

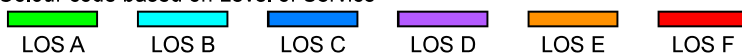

NA (TWSC): Level of Service is not defined for major road approaches or the intersection as a whole for Two-Way Sign Control (HCM LOS rule).

Site Level of Service (LOS) Method: Delay (SIDRA). Site LOS Method is specified in the Network Data dialog (Override Site Data tab).

Delay Model: SIDRA Standard (Control Delay: Geometric Delay is included).

DEGREE OF SATURATION

Ratio of Arrival Flow to Capacity, v/c ratio per lane

Network: N101 [2048_Opt10B_PM (Network Folder: General)]

Output produced by SIDRA INTERSECTION Version: 9.1.6.228

New Network

Network Category: (None)

Network Cycle Time = 130 seconds (Network Optimum Cycle Time - Minimum Delay)

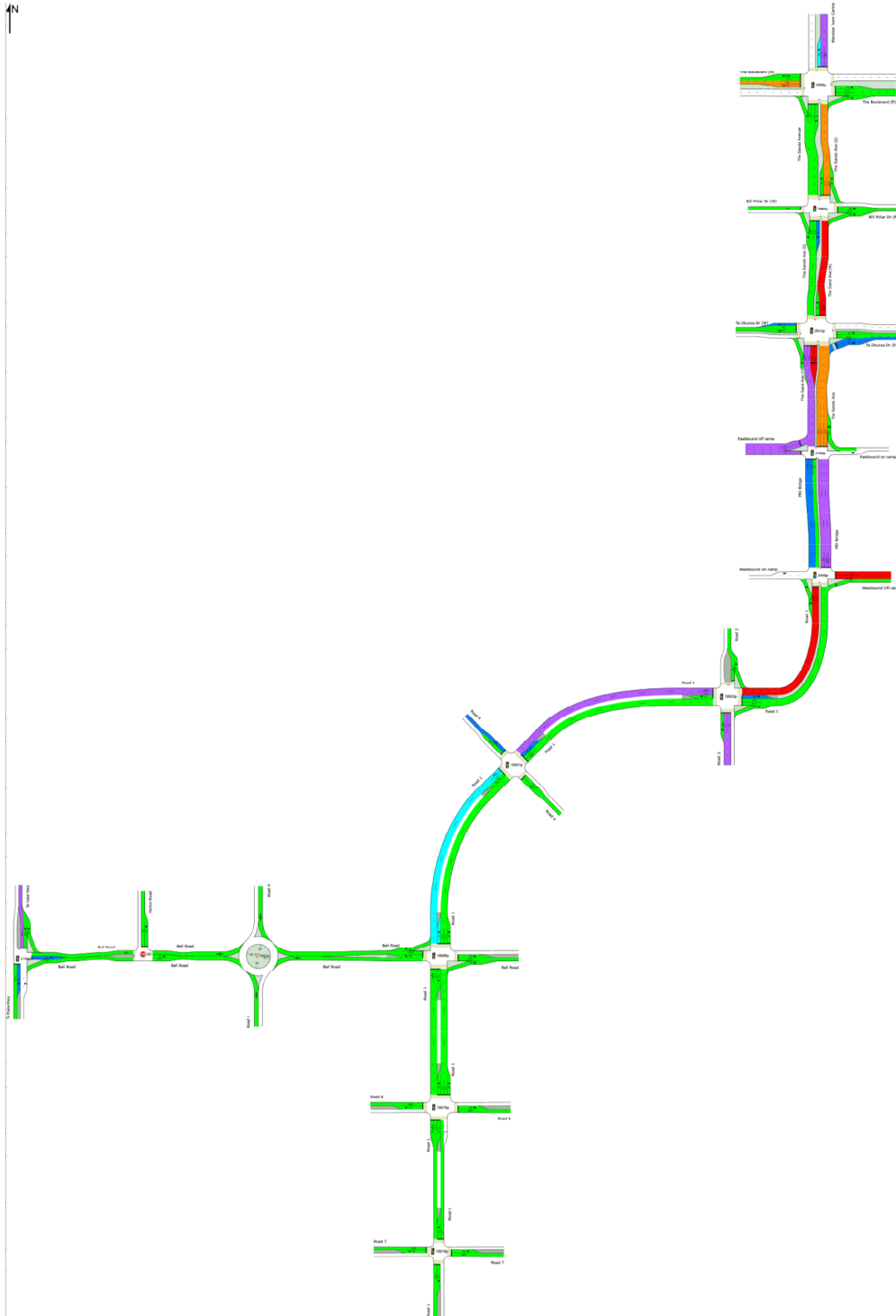

Colour code based on Degree of Saturation

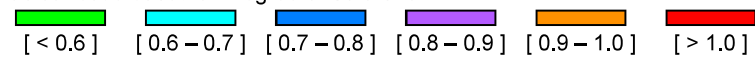

QUEUE STORAGE RATIO (PERCENTILE)

Ratio of the 95% Back of Queue Distance to the available queue storage distance per lane

Network: N101 [2048_Opt10B_PM (Network Folder: General)]

Output produced by SIDRA INTERSECTION Version: 9.1.6.228

New Network

Network Category: (None)

Network Cycle Time = 130 seconds (Network Optimum Cycle Time - Minimum Delay)

Short Lanes are not included in determining Queue Storage Ratios.

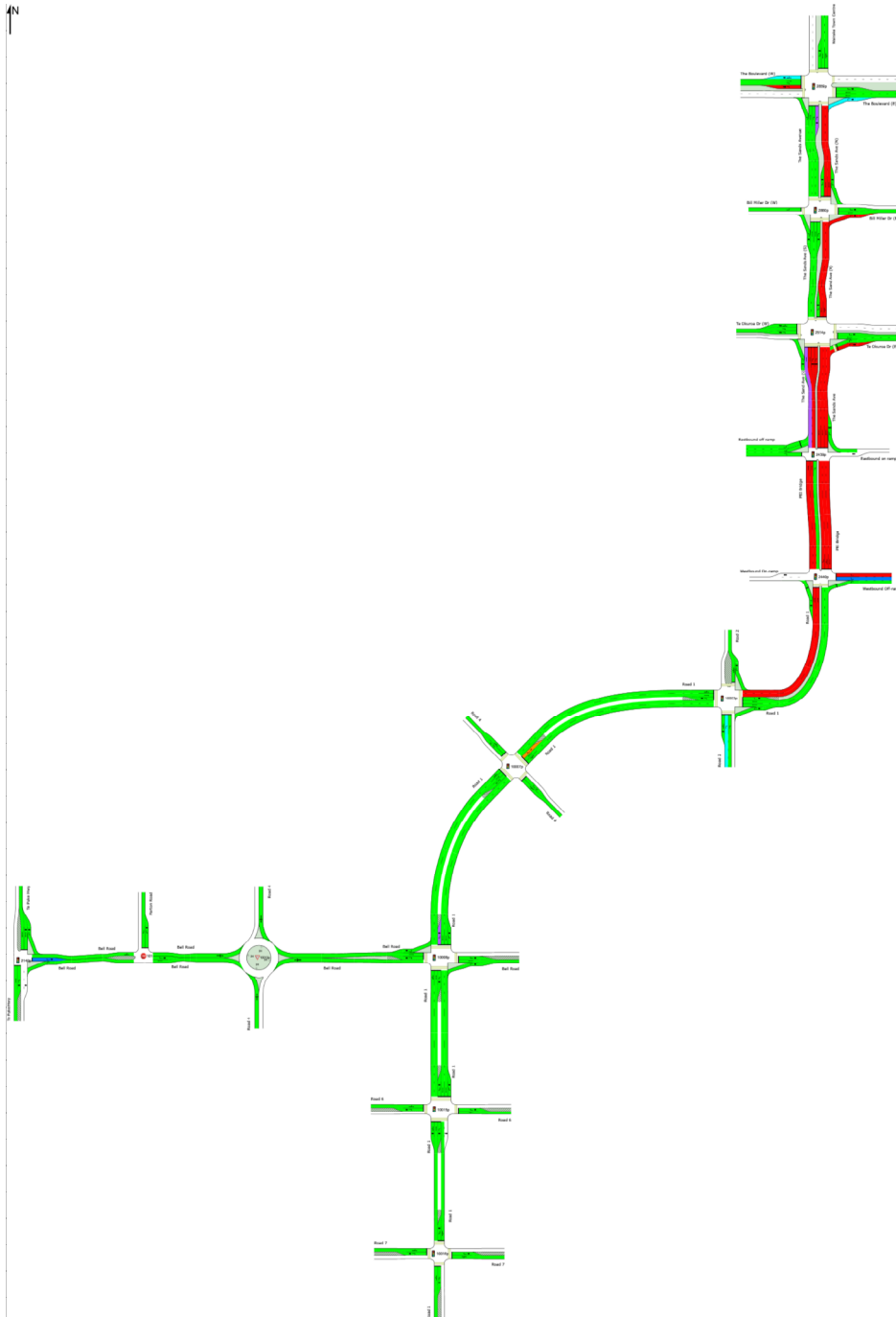

Colour code based on Queue Storage Ratio

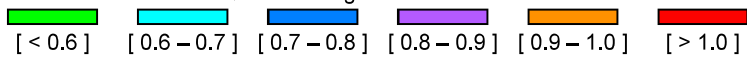

Queue Model: SIDRA queue estimation methods are used for Back of Queue and Queue at Start of Green.

CCG MOVEMENT SUMMARY

Common Control Group: CCG1 [CCG_PM1]

Output produced by SIDRA INTERSECTION Version: 9.1.6.228

Network: N101
[2048_Opt10B_PM (Network Folder: General)]

EQUISAT (Fixed-Time/SCATS) Coordinated Cycle Time = 130 seconds (Network Optimum Cycle Time - Minimum Delay)

Vehicle Movement Performance (CCG)															
Mov ID	Turn	Mov Class	Demand Flows		Arrival Flows		Deg. Satn	Aver. Delay	Level of Service	Aver. Back Of Queue		Prop. Que	Eff. Stop Rate	Aver. No. of Cycles	Aver. Speed
			[Total HV]	%	[Total HV]	%				[Veh. veh	Dist]				
Site: 2439p [2439 Papamoa Eastern Int North_PM]															
South: PEI Bridge															
2	T1	All MCs	1613	7.7	1234	7.8	0.768	14.8	LOS B	15.4	115.0	0.68	0.61	0.68	19.3
3	R2	All MCs	162	7.7	124	7.8	0.394	66.3	LOS E	4.8	36.0	1.00	0.84	1.00	20.1
Approach			1775	7.7	1358	7.8	0.768	19.5	LOS B	15.4	115.0	0.71	0.63	0.71	19.5
North: The Sands Ave															
7	L2	All MCs	565	7.7	544	7.7	0.306	4.5	LOS A	0.0	0.0	0.00	0.46	0.00	45.3
8	T1	All MCs	1572	7.7	1513	7.7	0.932	55.5	LOS E	24.5	183.1	0.97	1.11	1.25	12.7
Approach			2137	7.7	2057	7.7	0.932	42.0	LOS D	24.5	183.1	0.71	0.94	0.92	20.2
West: Eastbound off ramp															
10	L2	All MCs	1112	7.7	1112	7.7	0.807	41.6	LOS D	21.4	159.3	0.94	0.90	0.98	23.8
12	R2	All MCs	85	7.7	85	7.7	0.890	86.0	LOS F	4.0	29.9	1.00	1.05	1.48	15.1
Approach			1197	7.7	1197	7.7	0.890	44.8	LOS D	21.4	159.3	0.95	0.91	1.01	22.9
All Vehicles			5108	7.7	4612	8.5	0.932	36.1	LOS D	24.5	183.1	0.77	0.84	0.88	21.0
Site: 2440p [2440 Papamoa Eastern Int South_PM]															
South: Road 1															
1	L2	All MCs	239	7.4	239	7.4	0.215	15.5	LOS B	3.9	28.8	0.46	0.66	0.46	39.4
2	T1	All MCs	862	7.4	862	7.4	* 1.316	349.0	LOS F	43.4	323.1	1.00	2.34	2.80	3.5
Approach			1101	7.4	1101	7.4	1.316	276.6	LOS F	43.4	323.1	0.88	1.97	2.29	5.5
East: Westbound Off-ramp															
4	L2	All MCs	358	7.4	358	7.4	0.425	28.2	LOS C	9.0	67.0	0.70	0.76	0.70	28.6
6	R2	All MCs	907	7.4	907	7.4	* 1.295	336.3	LOS F	52.6	391.9	1.00	1.76	2.71	5.0
Approach			1265	7.4	1265	7.4	1.295	249.2	LOS F	52.6	391.9	0.92	1.48	2.14	6.5
North: PEI Bridge															
8	T1	All MCs	762	7.4	735	7.4	0.893	33.7	LOS C	15.4	115.0	0.94	0.93	1.03	10.6
9	R2	All MCs	887	7.4	856	7.4	* 0.893	48.9	LOS D	15.4	115.0	0.99	0.93	1.10	23.8
Approach			1649	7.4	1590	7.4	0.893	41.9	LOS D	15.4	115.0	0.96	0.93	1.07	20.1
All Vehicles			4016	7.4	3957	7.5	1.316	173.5	LOS F	52.6	391.9	0.93	1.39	1.75	8.0

Site Level of Service (LOS) Method: Delay (SIDRA). Site LOS Method is specified in the Network Data dialog (Override Site Data tab).

Vehicle movement LOS values are based on average delay per movement.

Intersection and Approach LOS values are based on average delay for all vehicle movements.

Delay Model: SIDRA Standard (Control Delay: Geometric Delay is included).

Gap-Acceptance Capacity Formula: SIDRA Standard (Akçelik M3D).

HV (%) values are calculated for All Movement Classes of All Heavy Vehicle Model Designation.

Arrival Flows used in performance calculations are adjusted to include any Initial Queued Demand and Upstream Capacity Constraint effects.

* Critical Movement (Signal Timing)

MOVEMENT SUMMARY

Site: 2859p [2859 Boulv_TheSand_PM (Site Folder: General)]

Output produced by SIDRA INTERSECTION Version: 9.1.6.228

Network: N101
[2048_Opt10B_PM (Network Folder: General)]

Site Category: (None)

Signals - EQUISAT (Fixed-Time/SCATS) Coordinated Cycle Time = 130 seconds (Network Optimum Cycle Time - Minimum Delay)

Vehicle Movement Performance													
Mov ID	Turn	Mov Class	Demand Flows [Total HV]	Arrival Flows [Total HV]	Deg. Satn	Aver. Delay	Level of Service	Aver. Back Of Queue	Prop. Que	Eff. Stop Rate	Aver. No. of Cycles	Aver. Speed	
			veh/h %	veh/h %	v/c	sec		[Veh. veh]				km/h	
								Dist]					
								m					
South: The Sands Avenue													
1	L2	All MCs	883 5.0	779 5.0	0.507	5.0	LOS A	2.5	0.13	0.54	0.13	41.6	
2	T1	All MCs	232 5.0	204 5.0	*0.391	16.9	LOS B	3.4	0.46	0.38	0.46	37.1	
3	R2	All MCs	471 5.0	415 5.0	0.442	35.0	LOS C	5.4	0.71	0.73	0.71	24.2	
Approach			1585 5.0	1398 5.0	0.507	15.6	LOS B	5.4	0.35	0.57	0.35	33.8	
East: The Boulevard (E)													
4	L2	All MCs	164 5.0	164 5.0	0.321	18.5	LOS B	3.2	0.55	0.69	0.55	27.8	
5	T1	All MCs	193 5.0	193 5.0	*0.414	58.1	LOS E	3.5	0.97	0.76	0.97	21.7	
6	R2	All MCs	23 5.0	23 5.0	0.073	52.6	LOS D	0.8	0.87	0.70	0.87	26.1	
Approach			380 5.0	380 5.0	0.414	40.6	LOS D	3.5	0.78	0.73	0.78	23.5	
North: Wairakei Town Centre													
7	L2	All MCs	8 5.0	8 5.0	0.819	82.1	LOS F	2.3	1.00	0.93	1.39	21.3	
8	T1	All MCs	91 5.0	91 5.0	0.819	77.9	LOS E	2.3	1.00	0.93	1.39	16.3	
9	R2	All MCs	55 5.0	55 5.0	*0.661	76.3	LOS E	2.3	1.00	0.82	1.13	21.5	
Approach			154 5.0	154 5.0	0.819	77.5	LOS E	2.3	1.00	0.89	1.30	18.6	
West: The Boulevard (W)													
10	L2	All MCs	38 5.0	38 5.0	0.187	39.1	LOS D	3.1	0.77	0.66	0.77	30.3	
11	T1	All MCs	183 5.0	183 5.0	0.187	34.5	LOS C	3.1	0.77	0.64	0.77	27.9	
12	R2	All MCs	580 5.0	580 5.0	*0.914	57.2	LOS E	11.0	1.00	1.05	1.33	14.2	
Approach			801 5.0	801 5.0	0.914	51.1	LOS D	11.0	0.94	0.93	1.18	18.2	
All Vehicles			2920 5.0	2733 5.3	0.914	33.0	LOS C	11.0	0.62	0.72	0.71	25.3	

Site Level of Service (LOS) Method: Delay (SIDRA). Site LOS Method is specified in the Network Data dialog (Override Site Data tab).

Vehicle movement LOS values are based on average delay per movement.

Intersection and Approach LOS values are based on average delay for all vehicle movements.

Delay Model: SIDRA Standard (Control Delay: Geometric Delay is included).

Queue Model: SIDRA queue estimation methods are used for Back of Queue and Queue at Start of Green.

Gap-Acceptance Capacity Formula: SIDRA Standard (Akçelik M3D).

HV (%) values are calculated for All Movement Classes of All Heavy Vehicle Model Designation.

Arrival Flows used in performance calculations are adjusted to include any Initial Queued Demand and Upstream Capacity Constraint effects.

* Critical Movement (Signal Timing)

Pedestrian Movement Performance											
Mov ID	Crossing	Dem. Flow	Aver. Delay	Level of Service	AVERAGE BACK OF QUEUE		Prop. Que	Eff. Stop Rate	Travel Time	Travel Dist.	Aver. Speed
		ped/h	sec		[Ped ped]	Dist]			sec	m	m/sec
						m					

South: The Sands Avenue											
P1 Full	32	59.2	LOS E	0.1	0.1	0.96	0.96	74.6	20.0	0.27	
East: The Boulevard (E)											
P21 Stage 1	32	32.0	LOS D	0.1	0.1	0.91	0.91	47.4	20.0	0.42	
P22 Stage 2	32	59.2	LOS E	0.1	0.1	0.96	0.96	74.6	20.0	0.27	
North: Wairakei Town Centre											
P3 Full	32	59.2	LOS E	0.1	0.1	0.96	0.96	74.6	20.0	0.27	
West: The Boulevard (W)											
P4 Full	32	59.2	LOS E	0.1	0.1	0.96	0.96	74.6	20.0	0.27	
All Pedestrians	158	53.8	LOS E	0.1	0.1	0.95	0.95	69.2	20.0	0.29	

Level of Service (LOS) Method: SIDRA Pedestrian LOS Method (Based on Average Delay)

Pedestrian movement LOS values are based on average delay per pedestrian movement.

Intersection LOS value for Pedestrians is based on average delay for all pedestrian movements.

SIDRA INTERSECTION 9.1 | Copyright © 2000-2024 Kcelik and Associates Pty Ltd | sidrasolutions.com

Organisation: AJW | Licence: NETWORK / 1PC | Processed: Friday, 27 March 2026 5:58:18 pm

Project: C:\Users\annaj\OneDrive\AW Consulting\Projects\Boffa Miskell Jobs\Wairakei South\ITA Work Feb 2026\Final SIDRA Modelling\Third Round Base Sidra File\2048_TTHM 10B Mitigated.sip9

MOVEMENT SUMMARY

Site: 2860p [2860 The Sand_Bill Miller_PM (Site Folder: General)]

Output produced by SIDRA INTERSECTION Version: 9.1.6.228

Network: N101
[2048_Opt10B_PM (Network Folder: General)]

Site Category: (None)

Signals - EQUISAT (Fixed-Time/SCATS) Coordinated Cycle Time = 130 seconds (Network Optimum Cycle Time - Minimum Delay)

Vehicle Movement Performance													
Mov ID	Turn	Mov Class	Demand Flows [Total HV]	Arrival Flows [Total HV]	Deg. Satn	Aver. Delay	Level of Service	Aver. Back Of Queue	Prop. Que	Eff. Stop Rate	Aver. No. of Cycles	Aver. Speed	
			veh/h %	veh/h %	v/c	sec		[Veh. veh	Dist] m			km/h	
South: The Sands Ave (S)													
1	L2	All MCs	51 5.5	44 5.5	0.028	4.6	LOS A	0.0	0.1	0.02	0.50	0.02	44.2
2	T1	All MCs	1528 5.5	1339 5.5	0.593	2.2	LOS A	4.8	35.1	0.17	0.15	0.17	41.5
3	R2	All MCs	68 5.5	60 5.5	*0.727	78.6	LOS E	2.5	18.5	1.00	0.82	1.10	18.4
Approach			1647 5.5	1443 5.5	0.727	5.4	LOS A	4.8	35.1	0.20	0.19	0.20	35.3
East: Bill Miller Dr (E)													
4	L2	All MCs	166 5.5	166 5.5	0.577	42.8	LOS D	5.3	38.5	0.88	0.88	0.88	23.4
5	T1	All MCs	4 5.5	4 5.5	0.018	53.9	LOS D	0.1	1.1	0.90	0.59	0.90	28.9
6	R2	All MCs	39 5.5	39 5.5	*0.472	74.6	LOS E	1.6	11.6	1.00	0.74	1.00	16.8
Approach			209 5.5	209 5.5	0.577	48.9	LOS D	5.3	38.5	0.90	0.85	0.90	22.0
North: The Sands Ave (N)													
7	L2	All MCs	64 5.5	64 5.5	0.040	4.8	LOS A	0.1	0.6	0.05	0.50	0.05	44.2
8	T1	All MCs	1071 5.5	1071 5.5	*0.967	76.6	LOS E	19.8	145.0	1.00	1.25	1.37	6.6
9	R2	All MCs	8 5.5	8 5.5	0.102	73.9	LOS E	0.3	2.5	1.00	0.67	1.00	19.3
Approach			1143 5.5	1143 5.5	0.967	72.6	LOS E	19.8	145.0	0.95	1.20	1.29	8.0
West: Bill Miller Dr (W)													
10	L2	All MCs	18 5.5	18 5.5	0.046	47.8	LOS D	0.5	4.0	0.82	0.69	0.82	21.9
Approach			18 5.5	18 5.5	0.046	47.8	LOS D	0.5	4.0	0.82	0.69	0.82	21.9
All Vehicles			3018 5.5	2814 5.9	0.967	36.2	LOS D	19.8	145.0	0.56	0.65	0.70	15.0

Site Level of Service (LOS) Method: Delay (SIDRA). Site LOS Method is specified in the Network Data dialog (Override Site Data tab).

Vehicle movement LOS values are based on average delay per movement.

Intersection and Approach LOS values are based on average delay for all vehicle movements.

Delay Model: SIDRA Standard (Control Delay: Geometric Delay is included).

Queue Model: SIDRA queue estimation methods are used for Back of Queue and Queue at Start of Green.

Gap-Acceptance Capacity Formula: SIDRA Standard (Akçelik M3D).

HV (%) values are calculated for All Movement Classes of All Heavy Vehicle Model Designation.

Arrival Flows used in performance calculations are adjusted to include any Initial Queued Demand and Upstream Capacity Constraint effects.

* Critical Movement (Signal Timing)

Pedestrian Movement Performance											
Mov ID	Crossing	Dem. Flow	Aver. Delay	Level of Service	AVERAGE BACK OF QUEUE		Prop. Que	Eff. Stop Rate	Travel Time	Travel Dist.	Aver. Speed
		ped/h	sec		[Ped ped	Dist] m			sec	m	m/sec
South: The Sands Ave (S)											
P1	Full	32	59.2	LOS E	0.1	0.1	0.96	0.96	74.6	20.0	0.27

East: Bill Miller Dr (E)											
P2	Full	32	59.2	LOS E	0.1	0.1	0.96	0.96	74.6	20.0	0.27
North: The Sands Ave (N)											
P3	Full	32	59.2	LOS E	0.1	0.1	0.96	0.96	74.6	20.0	0.27
West: Bill Miller Dr (W)											
P4	Full	32	59.2	LOS E	0.1	0.1	0.96	0.96	74.6	20.0	0.27
All Pedestrians		126	59.2	LOS E	0.1	0.1	0.96	0.96	74.6	20.0	0.27

Level of Service (LOS) Method: SIDRA Pedestrian LOS Method (Based on Average Delay)

Pedestrian movement LOS values are based on average delay per pedestrian movement.

Intersection LOS value for Pedestrians is based on average delay for all pedestrian movements.

SIDRA INTERSECTION 9.1 | Copyright © 2000-2024 Akcelik and Associates Pty Ltd | sidrasolutions.com

Organisation: AJW | Licence: NETWORK / 1PC | Processed: Friday, 27 March 2026 5:58:18 pm

Project: C:\Users\annaj\OneDrive\AW Consulting\Projects\Boffa Miskell Jobs\Wairakei South\ITA Work Feb 2026\Final SIDRA Modelling\Third Round Base Sidra File\2048_TTHM 10B Mitigated.sip9

MOVEMENT SUMMARY

Site: 2514p [2514 Sands_Te Okuroa_PM (Site Folder: General)]

Output produced by SIDRA INTERSECTION Version: 9.1.6.228

Network: N101
[2048_Opt10B_PM (Network Folder: General)]

Site Category: (None)

Signals - EQUISAT (Fixed-Time/SCATS) Coordinated Cycle Time = 130 seconds (Network Optimum Cycle Time - Minimum Delay)

Vehicle Movement Performance													
Mov ID	Turn	Mov Class	Demand Flows [Total HV]	Arrival Flows [Total HV]	Deg. Satn	Aver. Delay	Level of Service	Aver. Back Of Queue [Veh.]	Prop. Que	Eff. Stop Rate	Aver. No. of Cycles	Aver. Speed	
			veh/h %	veh/h %	v/c	sec		veh	Dist] m			km/h	
South: The Sand Ave (S)													
1	L2	All MCs	465 7.4	401 7.4	0.273	18.0	LOS B	2.3	17.4	0.22	0.57	0.22	44.0
2	T1	All MCs	1514 7.4	1305 7.4	0.819	34.8	LOS C	24.3	180.9	0.89	0.83	0.92	20.0
3	R2	All MCs	762 7.4	657 7.4	* 1.053	136.0	LOS F	19.1	141.9	1.00	1.29	1.68	14.5
Approach			2741 7.4	2363 7.4	1.053	60.1	LOS E	24.3	180.9	0.81	0.91	1.01	18.6
East: Te Okuroa Dr (E)													
4	L2	All MCs	804 7.4	804 7.4	0.753	44.9	LOS D	14.1	105.2	0.94	0.87	0.96	22.8
5	T1	All MCs	106 7.4	106 7.4	* 0.371	54.0	LOS D	3.8	28.0	0.94	0.75	0.94	29.0
6	R2	All MCs	65 7.4	65 7.4	0.240	57.3	LOS E	2.3	16.8	0.92	0.75	0.92	19.8
Approach			976 7.4	976 7.4	0.753	46.8	LOS D	14.1	105.2	0.94	0.85	0.96	23.6
North: The Sand Ave (N)													
7	L2	All MCs	67 7.4	67 7.4	1.072	136.7	LOS F	17.7	132.0	1.00	1.49	1.69	13.1
8	T1	All MCs	1133 7.4	1133 7.4	* 1.072	129.9	LOS F	17.7	132.0	1.00	1.51	1.69	4.1
9	R2	All MCs	35 7.4	35 7.4	0.427	82.7	LOS F	1.4	10.7	1.00	0.74	1.00	18.8
Approach			1235 7.4	1235 7.4	1.072	128.9	LOS F	17.7	132.0	1.00	1.48	1.67	5.0
West: Te Okuroa Dr (W)													
10	L2	All MCs	65 7.4	65 7.4	0.702	40.3	LOS D	5.6	41.9	1.00	0.88	1.06	20.5
11	T1	All MCs	97 7.4	97 7.4	* 0.702	64.1	LOS E	5.6	41.9	1.00	0.88	1.06	28.8
12	R2	All MCs	199 7.4	199 7.4	0.564	64.7	LOS E	4.1	28.4	0.99	0.79	0.99	18.5
Approach			361 7.4	361 7.4	0.702	60.2	LOS E	5.6	41.9	0.99	0.83	1.02	22.1
All Vehicles			5313 7.4	4935 8.0	1.072	74.7	LOS E	24.3	180.9	0.90	1.04	1.17	15.1

Site Level of Service (LOS) Method: Delay (SIDRA). Site LOS Method is specified in the Network Data dialog (Override Site Data tab).

Vehicle movement LOS values are based on average delay per movement.

Intersection and Approach LOS values are based on average delay for all vehicle movements.

Delay Model: SIDRA Standard (Control Delay: Geometric Delay is included).

Queue Model: SIDRA queue estimation methods are used for Back of Queue and Queue at Start of Green.

Gap-Acceptance Capacity Formula: SIDRA Standard (Akçelik M3D).

HV (%) values are calculated for All Movement Classes of All Heavy Vehicle Model Designation.

Arrival Flows used in performance calculations are adjusted to include any Initial Queued Demand and Upstream Capacity Constraint effects.

* Critical Movement (Signal Timing)

Pedestrian Movement Performance											
Mov ID	Crossing	Dem. Flow	Aver. Delay	Level of Service	AVERAGE BACK OF QUEUE [Ped Dist]		Prop. Que	Eff. Stop Rate	Travel Time	Travel Dist.	Aver. Speed
		ped/h	sec		ped	m			sec	m	m/sec

South: The Sand Ave (S)											
P1	Full	32	59.2	LOS E	0.1	0.1	0.96	0.96	74.6	20.0	0.27
East: Te Okuroa Dr (E)											
P2	Full	32	59.2	LOS E	0.1	0.1	0.96	0.96	74.6	20.0	0.27
P2B	Slip/ Bypass	32	59.2	LOS E	0.1	0.1	0.96	0.96	74.6	20.0	0.27
North: The Sand Ave (N)											
P3	Full	32	59.2	LOS E	0.1	0.1	0.96	0.96	74.6	20.0	0.27
West: Te Okuroa Dr (W)											
P4	Full	32	59.2	LOS E	0.1	0.1	0.96	0.96	74.6	20.0	0.27
All Pedestrians		158	59.2	LOS E	0.1	0.1	0.96	0.96	74.6	20.0	0.27

Level of Service (LOS) Method: SIDRA Pedestrian LOS Method (Based on Average Delay)

Pedestrian movement LOS values are based on average delay per pedestrian movement.

Intersection LOS value for Pedestrians is based on average delay for all pedestrian movements.

SIDRA INTERSECTION 9.1 | Copyright © 2000-2024 Akcelik and Associates Pty Ltd | sidrasolutions.com

Organisation: AJW | Licence: NETWORK / 1PC | Processed: Friday, 27 March 2026 5:58:18 pm

Project: C:\Users\annaj\OneDrive\AW Consulting\Projects\Boffa Miskell Jobs\Wairakei South\ITA Work Feb 2026\Final SIDRA Modelling\Third Round Base Sidra File\2048_TTHM 10B Mitigated.sip9

MOVEMENT SUMMARY

Site: 10003p [10003_PM (Site Folder: General)]

Output produced by SIDRA INTERSECTION Version: 9.1.6.228

Network: N101
[2048_Opt10B_PM (Network Folder: General)]

NA

Site Category: (None)

Signals - EQUISAT (Fixed-Time/SCATS) Isolated Cycle Time = 100 seconds (Site Practical Cycle Time)

Vehicle Movement Performance															
Mov ID	Turn	Mov Class	Demand Flows		Arrival Flows		Deg. Satn	Aver. Delay	Level of Service	Aver. Back Of Queue	Prop. Que	Eff. Stop Rate	Aver. No. of Cycles	Aver. Speed	
			[Total HV]	[Total HV]			v/c	sec		[Veh. veh	Dist]			km/h	
			veh/h	%	veh/h	%				veh	m				
South: Road 2															
1	L2	All MCs	6	6.9	6	6.9	0.028	28.0	LOS C	0.3	2.2	0.76	0.60	0.76	14.2
2	T1	All MCs	7	6.9	7	6.9	0.028	33.1	LOS C	0.3	2.2	0.76	0.60	0.76	30.5
3	R2	All MCs	458	6.9	458	6.9	*0.821	51.9	LOS D	7.9	58.6	1.00	0.97	1.23	9.5
Approach			472	6.9	472	6.9	0.821	51.3	LOS D	7.9	58.6	0.99	0.96	1.22	10.0
East: Road 1															
4	L2	All MCs	165	6.9	161	6.9	0.108	5.1	LOSA	0.4	3.1	0.16	0.55	0.16	41.9
5	T1	All MCs	491	6.9	479	6.9	0.414	29.5	LOS C	5.7	42.2	0.84	0.71	0.84	23.7
6	R2	All MCs	77	6.9	75	6.9	*0.706	59.8	LOS E	2.4	18.0	1.00	0.86	1.18	25.3
Approach			733	6.9	715	6.9	0.706	27.2	LOS C	5.7	42.2	0.70	0.69	0.72	27.1
North: Road 2															
7	L2	All MCs	68	6.9	68	6.9	0.136	18.9	LOS B	1.1	8.1	0.62	0.68	0.62	33.3
8	T1	All MCs	7	6.9	7	6.9	*0.088	41.1	LOS D	0.6	4.3	0.90	0.68	0.90	26.2
9	R2	All MCs	15	6.9	15	6.9	0.088	45.7	LOS D	0.6	4.3	0.90	0.68	0.90	23.0
Approach			91	6.9	91	6.9	0.136	25.0	LOS C	1.1	8.1	0.69	0.68	0.69	30.3
West: Road 1															
10	L2	All MCs	46	6.9	46	6.9	0.831	31.2	LOS C	10.8	80.0	0.99	1.00	1.17	30.1
11	T1	All MCs	576	6.9	576	6.9	*0.831	44.7	LOS D	10.8	80.0	0.99	1.01	1.19	21.3
12	R2	All MCs	39	6.9	39	6.9	0.367	57.0	LOS E	1.2	8.9	1.00	0.73	1.00	21.1
Approach			661	6.9	661	6.9	0.831	44.5	LOS D	10.8	80.0	0.99	0.99	1.18	22.1
All Vehicles			1956	6.9	1938	7.0	0.831	38.8	LOS D	10.8	80.0	0.87	0.86	1.00	21.3

Site Level of Service (LOS) Method: Delay (SIDRA). Site LOS Method is specified in the Network Data dialog (Override Site Data tab).

Vehicle movement LOS values are based on average delay per movement.

Intersection and Approach LOS values are based on average delay for all vehicle movements.

Delay Model: SIDRA Standard (Control Delay; Geometric Delay is included).

Queue Model: SIDRA queue estimation methods are used for Back of Queue and Queue at Start of Green.

Gap-Acceptance Capacity Formula: SIDRA Standard (Akçelik M3D).

HV (%) values are calculated for All Movement Classes of All Heavy Vehicle Model Designation.

Arrival Flows used in performance calculations are adjusted to include any Initial Queued Demand and Upstream Capacity Constraint effects.

* Critical Movement (Signal Timing)

Pedestrian Movement Performance											
Mov ID	Crossing	Dem. Flow	Aver. Delay	Level of Service	AVERAGE BACK OF QUEUE		Prop. Que	Eff. Stop Rate	Travel Time	Travel Dist.	Aver. Speed
		ped/h	sec		[Ped ped	Dist]			sec	m	m/sec
					ped	m					
South: Road 2											
P1	Full	32	44.2	LOS E	0.1	0.1	0.94	0.94	198.1	200.0	1.01

East: Road 1											
P2	Full	32	44.2	LOS E	0.1	0.1	0.94	0.94	198.1	200.0	1.01
North: Road 2											
P3	Full	32	44.2	LOS E	0.1	0.1	0.94	0.94	198.1	200.0	1.01
West: Road 1											
P4	Full	32	44.2	LOS E	0.1	0.1	0.94	0.94	198.1	200.0	1.01
All Pedestrians		126	44.2	LOS E	0.1	0.1	0.94	0.94	198.1	200.0	1.01

Level of Service (LOS) Method: SIDRA Pedestrian LOS Method (Based on Average Delay)

Pedestrian movement LOS values are based on average delay per pedestrian movement.

Intersection LOS value for Pedestrians is based on average delay for all pedestrian movements.

SIDRA INTERSECTION 9.1 | Copyright © 2000-2024 Akcelik and Associates Pty Ltd | sidrasolutions.com

Organisation: AJW | Licence: NETWORK / 1PC | Processed: Friday, 27 March 2026 5:58:18 pm

Project: C:\Users\annaj\OneDrive\AW Consulting\Projects\Boffa Miskell Jobs\Wairakei South\ITA Work Feb 2026\Final SIDRA Modelling\Third Round Base Sidra File\2048_TTHM 10B Mitigated.sip9

MOVEMENT SUMMARY

Site: 10007p [10007_PM (Site Folder: General)]

Output produced by SIDRA INTERSECTION Version: 9.1.6.228

Network: N101
[2048_Opt10B_PM (Network Folder: General)]

NA

Site Category: (None)

Signals - EQUISAT (Fixed-Time/SCATS) Isolated Cycle Time = 70 seconds (Site Practical Cycle Time)

Vehicle Movement Performance															
Mov ID	Turn	Mov Class	Demand Flows		Arrival Flows		Deg. Satn	Aver. Delay	Level of Service	Aver. Back Of Queue	Prop. Que	Eff. Stop Rate	Aver. No. of Cycles	Aver. Speed	
			[Total HV]	[Total HV]			v/c	sec		[Veh. veh]	[Dist] m			km/h	
			veh/h	%	veh/h	%									
SouthEast: Road 4															
21	L2	All MCs	23	11.9	23	11.9	0.073	26.1	LOS C	0.5	4.0	0.79	0.66	0.79	30.0
22	T1	All MCs	9	11.9	9	11.9	0.073	21.5	LOS C	0.5	4.0	0.79	0.66	0.79	37.2
23	R2	All MCs	11	11.9	11	11.9	*0.072	38.3	LOS D	0.2	1.7	0.95	0.67	0.95	24.7
Approach			43	11.9	43	11.9	0.073	28.1	LOS C	0.5	4.0	0.83	0.66	0.83	30.8
NorthEast: Road 1															
24	L2	All MCs	1	11.9	1	12.0	0.529	35.4	LOS D	3.0	23.5	0.97	0.77	0.97	33.7
25	T1	All MCs	306	11.9	300	12.0	0.529	30.7	LOS C	3.0	23.5	0.97	0.77	0.97	25.5
26	R2	All MCs	203	11.9	199	12.0	*0.739	38.8	LOS D	4.4	33.9	1.00	0.90	1.17	31.0
Approach			511	11.9	499	12.0	0.739	33.9	LOS C	4.4	33.9	0.98	0.83	1.05	28.4
NorthWest: Road 4															
27	L2	All MCs	327	11.9	327	11.9	0.764	34.2	LOS C	7.2	55.6	0.98	0.91	1.12	25.6
28	T1	All MCs	9	11.9	9	11.9	*0.764	29.5	LOS C	7.2	55.6	0.98	0.91	1.12	33.9
29	R2	All MCs	2	11.9	2	11.9	0.014	37.5	LOS D	0.0	0.3	0.93	0.61	0.93	24.4
Approach			339	11.9	339	11.9	0.764	34.1	LOS C	7.2	55.6	0.98	0.91	1.12	26.0
SouthWest: Road 1															
30	L2	All MCs	22	11.9	22	11.9	0.613	36.2	LOS D	3.6	27.7	0.98	0.82	1.02	29.7
31	T1	All MCs	325	11.9	325	11.9	*0.613	31.5	LOS C	3.6	27.9	0.98	0.82	1.02	16.3
32	R2	All MCs	73	11.9	73	11.9	0.270	33.9	LOS C	1.4	10.8	0.92	0.75	0.92	29.4
Approach			420	11.9	420	11.9	0.613	32.2	LOS C	3.6	27.9	0.97	0.81	1.00	20.9
All Vehicles			1313	11.9	1301	12.0	0.764	33.2	LOS C	7.2	55.6	0.97	0.84	1.04	25.9

Site Level of Service (LOS) Method: Delay (SIDRA). Site LOS Method is specified in the Network Data dialog (Override Site Data tab).

Vehicle movement LOS values are based on average delay per movement.

Intersection and Approach LOS values are based on average delay for all vehicle movements.

Delay Model: SIDRA Standard (Control Delay; Geometric Delay is included).

Queue Model: SIDRA queue estimation methods are used for Back of Queue and Queue at Start of Green.

Gap-Acceptance Capacity Formula: SIDRA Standard (Akçelik M3D).

HV (%) values are calculated for All Movement Classes of All Heavy Vehicle Model Designation.

Arrival Flows used in performance calculations are adjusted to include any Initial Queued Demand and Upstream Capacity Constraint effects.

* Critical Movement (Signal Timing)

Pedestrian Movement Performance											
Mov ID	Crossing	Dem. Flow	Aver. Delay	Level of Service	AVERAGE BACK OF QUEUE		Prop. Que	Eff. Stop Rate	Travel Time	Travel Dist.	Aver. Speed
		ped/h	sec		[Ped ped]	[Dist] m			sec	m	m/sec
SouthEast: Road 4											
P5	Full	32	29.3	LOS C	0.1	0.1	0.92	0.92	183.1	200.0	1.09

NorthEast: Road 1											
P6	Full	32	29.3	LOS C	0.1	0.1	0.92	0.92	183.1	200.0	1.09
NorthWest: Road 4											
P7	Full	32	29.3	LOS C	0.1	0.1	0.92	0.92	183.1	200.0	1.09
SouthWest: Road 1											
P8	Full	32	29.3	LOS C	0.1	0.1	0.92	0.92	183.1	200.0	1.09
All Pedestrians		126	29.3	LOS C	0.1	0.1	0.92	0.92	183.1	200.0	1.09

Level of Service (LOS) Method: SIDRA Pedestrian LOS Method (Based on Average Delay)

Pedestrian movement LOS values are based on average delay per pedestrian movement.

Intersection LOS value for Pedestrians is based on average delay for all pedestrian movements.

SIDRA INTERSECTION 9.1 | Copyright © 2000-2024 Akcelik and Associates Pty Ltd | sidrasolutions.com

Organisation: AJW | Licence: NETWORK / 1PC | Processed: Friday, 27 March 2026 5:58:18 pm

Project: C:\Users\annaj\OneDrive\AW Consulting\Projects\Boffa Miskell Jobs\Wairakei South\ITA Work Feb 2026\Final SIDRA Modelling\Third Round Base Sidra File\2048_TTHM 10B Mitigated.sip9

MOVEMENT SUMMARY

Site: 10008p [10008_PM (Site Folder: General)]

Output produced by SIDRA INTERSECTION Version: 9.1.6.228

Network: N101
[2048_Opt10B_PM (Network Folder: General)]

New Site

Site Category: (None)

Signals - EQUISAT (Fixed-Time/SCATS) Isolated Cycle Time = 70 seconds (Site Practical Cycle Time)

Vehicle Movement Performance															
Mov ID	Turn	Mov Class	Demand Flows		Arrival Flows		Deg. Satn	Aver. Delay	Level of Service	Aver. Back Of Queue		Prop. Que	Eff. Stop Rate	Aver. No. of Cycles	Aver. Speed
			[Total HV] veh/h	%	[Total HV] veh/h	%				[Veh. veh	[Dist] m				
South: Road 1															
1	L2	All MCs	5	11.9	5	11.9	0.435	23.6	LOS C	2.5	18.9	0.94	0.75	0.94	26.3
2	T1	All MCs	243	11.9	243	11.9	*0.435	30.0	LOS C	2.5	19.0	0.94	0.75	0.94	26.2
3	R2	All MCs	27	11.9	27	11.9	0.093	31.8	LOS C	0.5	3.8	0.87	0.70	0.87	34.2
Approach			276	11.9	276	11.9	0.435	30.1	LOS C	2.5	19.0	0.94	0.75	0.94	27.5
East: Bell Road															
4	L2	All MCs	89	11.9	89	11.9	0.066	5.4	LOS A	0.2	1.8	0.22	0.56	0.22	44.1
5	T1	All MCs	59	11.9	59	11.9	*0.134	22.8	LOS C	1.0	7.6	0.82	0.62	0.82	32.2
6	R2	All MCs	34	11.9	34	11.9	*0.230	39.3	LOS D	0.7	5.5	0.97	0.72	0.97	25.6
Approach			182	11.9	182	11.9	0.230	17.3	LOS B	1.0	7.6	0.55	0.61	0.55	35.2
North: Road 1															
7	L2	All MCs	7	11.9	7	12.0	0.013	21.6	LOS C	0.1	0.8	0.69	0.63	0.69	35.0
8	T1	All MCs	127	11.9	125	12.0	0.219	28.9	LOS C	1.2	9.2	0.91	0.69	0.91	17.5
9	R2	All MCs	201	11.9	197	12.0	*0.672	36.4	LOS D	4.2	32.2	0.99	0.86	1.07	15.1
Approach			336	11.9	329	12.0	0.672	33.2	LOS C	4.2	32.2	0.95	0.79	1.00	16.6
West: Bell Road															
10	L2	All MCs	139	11.9	139	11.9	0.109	5.9	LOS A	0.5	4.0	0.28	0.58	0.28	42.4
11	T1	All MCs	45	11.9	45	11.9	0.103	22.5	LOS C	0.7	5.8	0.81	0.61	0.81	38.2
12	R2	All MCs	3	11.9	3	11.9	0.022	37.7	LOS D	0.1	0.5	0.94	0.62	0.94	23.3
Approach			187	11.9	187	11.9	0.109	10.5	LOS B	0.7	5.8	0.42	0.59	0.42	40.2
All Vehicles			981	11.9	974	12.0	0.672	25.0	LOS C	4.2	32.2	0.77	0.70	0.79	28.0

Site Level of Service (LOS) Method: Delay (SIDRA). Site LOS Method is specified in the Network Data dialog (Override Site Data tab).

Vehicle movement LOS values are based on average delay per movement.

Intersection and Approach LOS values are based on average delay for all vehicle movements.

Delay Model: SIDRA Standard (Control Delay; Geometric Delay is included).

Queue Model: SIDRA queue estimation methods are used for Back of Queue and Queue at Start of Green.

Gap-Acceptance Capacity Formula: SIDRA Standard (Akçelik M3D).

HV (%) values are calculated for All Movement Classes of All Heavy Vehicle Model Designation.

Arrival Flows used in performance calculations are adjusted to include any Initial Queued Demand and Upstream Capacity Constraint effects.

* Critical Movement (Signal Timing)

Pedestrian Movement Performance											
Mov ID	Crossing	Dem. Flow	Aver. Delay	Level of Service	AVERAGE BACK OF QUEUE		Prop. Que	Eff. Stop Rate	Travel Time	Travel Dist.	Aver. Speed
					[Ped ped	[Dist] m					
		ped/h	sec					sec	m	m/sec	
South: Road 1											
P1	Full	32	29.3	LOS C	0.1	0.1	0.92	0.92	183.1	200.0	1.09

East: Bell Road											
P2	Full	32	29.3	LOS C	0.1	0.1	0.92	0.92	183.1	200.0	1.09
North: Road 1											
P3	Full	32	29.3	LOS C	0.1	0.1	0.92	0.92	183.1	200.0	1.09
West: Bell Road											
P4	Full	32	29.3	LOS C	0.1	0.1	0.92	0.92	183.1	200.0	1.09
All Pedestrians		126	29.3	LOS C	0.1	0.1	0.92	0.92	183.1	200.0	1.09

Level of Service (LOS) Method: SIDRA Pedestrian LOS Method (Based on Average Delay)

Pedestrian movement LOS values are based on average delay per pedestrian movement.

Intersection LOS value for Pedestrians is based on average delay for all pedestrian movements.

SIDRA INTERSECTION 9.1 | Copyright © 2000-2024 Akcelik and Associates Pty Ltd | sidrasolutions.com

Organisation: AJW | Licence: NETWORK / 1PC | Processed: Friday, 27 March 2026 5:58:18 pm

Project: C:\Users\annaj\OneDrive\AW Consulting\Projects\Boffa Miskell Jobs\Wairakei South\ITA Work Feb 2026\Final SIDRA Modelling\Third Round Base Sidra File\2048_TTHM 10B Mitigated.sip9

MOVEMENT SUMMARY

Site: 10015p [10015_PM (Site Folder: General)]

Output produced by SIDRA INTERSECTION Version: 9.1.6.228

Network: N101
[2048_Opt10B_PM (Network Folder: General)]

New Site

Site Category: (None)

Signals - EQUISAT (Fixed-Time/SCATS) Isolated Cycle Time = 70 seconds (Site Practical Cycle Time)

Vehicle Movement Performance															
Mov ID	Turn	Mov Class	Demand Flows		Arrival Flows		Deg. Satn	Aver. Delay	Level of Service	Aver. Back Of Queue		Prop. Que	Eff. Stop Rate	Aver. No. of Cycles	Aver. Speed
			[Total HV]	[Total HV]	[Total HV]	[Total HV]	v/c	sec		[Veh. veh	Dist]				km/h
			veh/h	%	veh/h	%					m				
South: Road 1															
1	L2	All MCs	4	13.5	4	13.5	0.147	21.4	LOS C	0.8	6.0	0.88	0.67	0.88	35.1
2	T1	All MCs	79	13.5	79	13.5	0.147	28.6	LOS C	0.8	6.0	0.89	0.67	0.89	26.8
3	R2	All MCs	1	13.5	1	13.5	0.004	32.7	LOS C	0.0	0.1	0.87	0.59	0.87	33.2
Approach			84	13.5	84	13.5	0.147	28.3	LOS C	0.8	6.0	0.89	0.66	0.89	27.6
East: Road 6															
4	L2	All MCs	1	13.5	1	13.5	0.058	15.3	LOS B	0.4	3.2	0.78	0.58	0.78	31.8
5	T1	All MCs	24	13.5	24	13.5	0.058	21.8	LOS C	0.4	3.2	0.78	0.58	0.78	38.9
6	R2	All MCs	55	13.5	55	13.5	*0.283	37.2	LOS D	1.1	8.7	0.95	0.74	0.95	25.1
Approach			80	13.5	80	13.5	0.283	32.2	LOS C	1.1	8.7	0.90	0.69	0.90	30.2
North: Road 1															
7	L2	All MCs	28	13.5	28	13.6	0.046	20.5	LOS C	0.4	3.0	0.68	0.67	0.68	37.6
8	T1	All MCs	66	13.5	66	13.6	*0.151	28.3	LOS C	0.8	6.2	0.89	0.66	0.89	26.8
9	R2	All MCs	76	13.5	75	13.6	*0.310	35.2	LOS D	1.5	11.6	0.94	0.75	0.94	32.8
Approach			171	13.5	169	13.6	0.310	30.1	LOS C	1.5	11.6	0.88	0.70	0.88	32.0
West: Road 6															
10	L2	All MCs	64	13.5	64	13.5	0.126	18.1	LOS B	1.1	8.4	0.69	0.68	0.69	33.4
11	T1	All MCs	13	13.5	13	13.5	*0.126	27.6	LOS C	1.1	8.4	0.69	0.68	0.69	39.7
12	R2	All MCs	2	13.5	2	13.5	0.011	35.1	LOS D	0.0	0.3	0.91	0.61	0.91	26.5
Approach			79	13.5	79	13.5	0.126	20.1	LOS C	1.1	8.4	0.70	0.68	0.70	34.7
All Vehicles			414	13.5	412	13.6	0.310	28.2	LOS C	1.5	11.6	0.85	0.69	0.85	31.3

Site Level of Service (LOS) Method: Delay (SIDRA). Site LOS Method is specified in the Network Data dialog (Override Site Data tab).

Vehicle movement LOS values are based on average delay per movement.

Intersection and Approach LOS values are based on average delay for all vehicle movements.

Delay Model: SIDRA Standard (Control Delay; Geometric Delay is included).

Queue Model: SIDRA queue estimation methods are used for Back of Queue and Queue at Start of Green.

Gap-Acceptance Capacity Formula: SIDRA Standard (Akçelik M3D).

HV (%) values are calculated for All Movement Classes of All Heavy Vehicle Model Designation.

Arrival Flows used in performance calculations are adjusted to include any Initial Queued Demand and Upstream Capacity Constraint effects.

* Critical Movement (Signal Timing)

Pedestrian Movement Performance											
Mov ID	Crossing	Dem. Flow	Aver. Delay	Level of Service	AVERAGE BACK OF QUEUE		Prop. Que	Eff. Stop Rate	Travel Time	Travel Dist.	Aver. Speed
		ped/h	sec		[Ped ped	Dist]			sec	m	m/sec
						m					
South: Road 1											
P1	Full	32	29.3	LOS C	0.1	0.1	0.92	0.92	183.1	200.0	1.09

East: Road 6											
P2	Full	32	29.3	LOS C	0.1	0.1	0.92	0.92	183.1	200.0	1.09
North: Road 1											
P3	Full	32	29.3	LOS C	0.1	0.1	0.92	0.92	183.1	200.0	1.09
West: Road 6											
P4	Full	32	29.3	LOS C	0.1	0.1	0.92	0.92	183.1	200.0	1.09
All Pedestrians		126	29.3	LOS C	0.1	0.1	0.92	0.92	183.1	200.0	1.09

Level of Service (LOS) Method: SIDRA Pedestrian LOS Method (Based on Average Delay)

Pedestrian movement LOS values are based on average delay per pedestrian movement.

Intersection LOS value for Pedestrians is based on average delay for all pedestrian movements.

SIDRA INTERSECTION 9.1 | Copyright © 2000-2024 Akcelik and Associates Pty Ltd | sidrasolutions.com

Organisation: AJW | Licence: NETWORK / 1PC | Processed: Friday, 27 March 2026 5:58:18 pm

Project: C:\Users\annaj\OneDrive\AW Consulting\Projects\Boffa Miskell Jobs\Wairakei South\ITA Work Feb 2026\Final SIDRA Modelling\Third Round Base Sidra File\2048_TTHM 10B Mitigated.sip9

MOVEMENT SUMMARY

Site: 10016p [10016_PM (Site Folder: General)]

Output produced by SIDRA INTERSECTION Version: 9.1.6.228

Network: N101
[2048_Opt10B_PM (Network Folder: General)]

New Site

Site Category: (None)

Signals - EQUISAT (Fixed-Time/SCATS) Isolated Cycle Time = 60 seconds (Site Practical Cycle Time)

Vehicle Movement Performance															
Mov ID	Turn	Mov Class	Demand Flows [Total HV] veh/h %		Arrival Flows [Total HV] veh/h %		Deg. Satn v/c	Aver. Delay sec	Level of Service	Aver. Back Of Queue [Veh. Dist] veh m		Prop. Que	Eff. Stop Rate	Aver. No. of Cycles	Aver. Speed km/h
South: Road 1															
1	L2	All MCs	1	14.0	1	14.0	0.010	26.6	LOS C	0.0	0.4	0.84	0.56	0.84	37.9
2	T1	All MCs	2	14.0	2	14.0	0.010	21.9	LOS C	0.0	0.4	0.84	0.56	0.84	30.6
3	R2	All MCs	1	14.0	1	14.0	0.005	29.5	LOS C	0.0	0.1	0.88	0.59	0.88	34.9
Approach			4	14.0	4	14.0	0.010	25.0	LOS C	0.0	0.4	0.85	0.57	0.85	34.3
East: Road 7															
4	L2	All MCs	1	14.0	1	14.0	0.041	16.0	LOS B	0.2	1.6	0.83	0.59	0.83	37.6
5	T1	All MCs	13	14.0	13	14.0	0.041	22.2	LOS C	0.2	1.6	0.83	0.59	0.83	39.3
6	R2	All MCs	29	14.0	29	14.0	*0.175	33.4	LOS C	0.5	4.1	0.95	0.71	0.95	26.3
Approach			43	14.0	43	14.0	0.175	29.7	LOS C	0.5	4.1	0.91	0.67	0.91	31.5
North: Road 1															
7	L2	All MCs	15	14.0	15	14.1	0.050	27.1	LOS C	0.2	1.9	0.85	0.67	0.85	35.2
8	T1	All MCs	1	14.0	1	14.1	*0.050	22.4	LOS C	0.2	1.9	0.85	0.67	0.85	36.0
9	R2	All MCs	55	14.0	54	14.1	*0.241	31.4	LOS C	0.9	7.3	0.93	0.74	0.93	34.6
Approach			71	14.0	70	14.1	0.241	30.4	LOS C	0.9	7.3	0.91	0.72	0.91	34.8
West: Road 7															
10	L2	All MCs	51	14.0	51	14.0	0.100	17.7	LOS B	0.7	5.5	0.70	0.68	0.70	35.3
11	T1	All MCs	6	14.0	6	14.0	*0.100	25.4	LOS C	0.7	5.5	0.70	0.68	0.70	40.7
12	R2	All MCs	1	14.0	1	14.0	0.006	31.8	LOS C	0.0	0.1	0.92	0.59	0.92	35.1
Approach			58	14.0	58	14.0	0.100	18.8	LOS B	0.7	5.5	0.71	0.68	0.71	36.2
All Vehicles			176	14.0	175	14.1	0.241	26.2	LOS C	0.9	7.3	0.84	0.69	0.84	34.4

Site Level of Service (LOS) Method: Delay (SIDRA). Site LOS Method is specified in the Network Data dialog (Override Site Data tab).

Vehicle movement LOS values are based on average delay per movement.

Intersection and Approach LOS values are based on average delay for all vehicle movements.

Delay Model: SIDRA Standard (Control Delay; Geometric Delay is included).

Queue Model: SIDRA queue estimation methods are used for Back of Queue and Queue at Start of Green.

Gap-Acceptance Capacity Formula: SIDRA Standard (Akçelik M3D).

HV (%) values are calculated for All Movement Classes of All Heavy Vehicle Model Designation.

Arrival Flows used in performance calculations are adjusted to include any Initial Queued Demand and Upstream Capacity Constraint effects.

* Critical Movement (Signal Timing)

Pedestrian Movement Performance											
Mov ID	Crossing	Dem. Flow ped/h	Aver. Delay sec	Level of Service	AVERAGE BACK OF QUEUE [Ped Dist] ped m		Prop. Que	Eff. Stop Rate	Travel Time sec	Travel Dist. m	Aver. Speed m/sec
South: Road 1											
P1	Full	32	24.3	LOS C	0.0	0.0	0.90	0.90	178.2	200.0	1.12

East: Road 7											
P2	Full	32	24.3	LOS C	0.0	0.0	0.90	0.90	178.2	200.0	1.12
North: Road 1											
P3	Full	32	24.3	LOS C	0.0	0.0	0.90	0.90	178.2	200.0	1.12
West: Road 7											
P4	Full	32	24.3	LOS C	0.0	0.0	0.90	0.90	178.2	200.0	1.12
All Pedestrians		126	24.3	LOS C	0.0	0.0	0.90	0.90	178.2	200.0	1.12

Level of Service (LOS) Method: SIDRA Pedestrian LOS Method (Based on Average Delay)

Pedestrian movement LOS values are based on average delay per pedestrian movement.

Intersection LOS value for Pedestrians is based on average delay for all pedestrian movements.

SIDRA INTERSECTION 9.1 | Copyright © 2000-2024 Akcelik and Associates Pty Ltd | sidrasolutions.com

Organisation: AJW | Licence: NETWORK / 1PC | Processed: Friday, 27 March 2026 5:58:18 pm

Project: C:\Users\annaj\OneDrive\AW Consulting\Projects\Boffa Miskell Jobs\Wairakei South\ITA Work Feb 2026\Final SIDRA Modelling\Third Round Base Sidra File\2048_TTHM 10B Mitigated.sip9

MOVEMENT SUMMARY

Site: 10013p [10013_PM (Site Folder: General)]

Output produced by SIDRA INTERSECTION Version: 9.1.6.228

Network: N101
[2048_Opt10B_PM (Network Folder: General)]

Site Category: (None)
Roundabout

Vehicle Movement Performance															
Mov ID	Turn	Mov Class	Demand Flows		Arrival Flows		Deg. Satn	Aver. Delay	Level of Service	Aver. Back Of Queue		Prop. Que	Eff. Stop Rate	Aver. No. of Cycles	Aver. Speed
			[Total HV]	%	[Total HV]	%				[Veh. veh	Dist]				
South: Road 4															
1	L2	All MCs	266	4.2	266	4.2	0.350	4.6	LOS A	1.0	7.1	0.56	0.52	0.56	41.9
2	T1	All MCs	74	4.2	74	4.2	0.350	4.4	LOS A	1.0	7.1	0.56	0.52	0.56	44.0
3	R2	All MCs	39	4.2	39	4.2	0.350	9.4	LOS A	1.0	7.1	0.56	0.52	0.56	41.9
Approach			379	4.2	379	4.2	0.350	5.1	LOS A	1.0	7.1	0.56	0.52	0.56	42.5
East: Bell Road															
4	L2	All MCs	73	4.2	72	4.2	0.261	4.8	LOS A	0.5	3.9	0.43	0.52	0.43	45.5
5	T1	All MCs	181	4.2	178	4.2	0.261	4.6	LOS A	0.5	3.9	0.43	0.52	0.43	43.3
6	R2	All MCs	15	4.2	15	4.2	0.261	9.6	LOS A	0.5	3.9	0.43	0.52	0.43	44.0
Approach			268	4.2	265	4.2	0.261	4.9	LOS A	0.5	3.9	0.43	0.52	0.43	44.2
North: Road 4															
7	L2	All MCs	1	4.2	1	4.2	0.147	4.8	LOS A	0.3	2.4	0.56	0.63	0.56	34.6
8	T1	All MCs	29	4.2	29	4.2	0.147	4.6	LOS A	0.3	2.4	0.56	0.63	0.56	41.8
9	R2	All MCs	112	4.2	112	4.2	0.147	9.6	LOS A	0.3	2.4	0.56	0.63	0.56	34.6
Approach			142	4.2	142	4.2	0.147	8.5	LOS A	0.3	2.4	0.56	0.63	0.56	37.0
West: Bell Road															
10	L2	All MCs	272	4.2	272	4.2	0.489	3.5	LOS A	1.6	11.9	0.45	0.48	0.45	48.4
11	T1	All MCs	147	4.2	147	4.2	0.489	3.3	LOS A	1.6	11.9	0.45	0.48	0.45	48.5
12	R2	All MCs	226	4.2	226	4.2	0.489	8.3	LOS A	1.6	11.9	0.45	0.48	0.45	48.4
Approach			645	4.2	645	4.2	0.489	5.2	LOS A	1.6	11.9	0.45	0.48	0.45	48.4
All Vehicles			1435	4.2	1431	4.2	0.489	5.4	LOS A	1.6	11.9	0.49	0.51	0.49	47.3

Site Level of Service (LOS) Method: Delay (SIDRA). Site LOS Method is specified in the Network Data dialog (Override Site Data tab).

Roundabout LOS Method: SIDRA Roundabout LOS.

Vehicle movement LOS values are based on average delay per movement.

Intersection and Approach LOS values are based on average delay for all vehicle movements.

Roundabout Capacity Model: SIDRA Standard.

Delay Model: SIDRA Standard (Control Delay: Geometric Delay is included).

Queue Model: SIDRA queue estimation methods are used for Back of Queue and Queue at Start of Gap.

Gap-Acceptance Capacity Formula: SIDRA Standard (Akçelik M3D).

HV (%) values are calculated for All Movement Classes of All Heavy Vehicle Model Designation.

Arrival Flows used in performance calculations are adjusted to include any Initial Queued Demand and Upstream Capacity Constraint effects.

SIDRA INTERSECTION 9.1 | Copyright © 2000-2024 Akcelik and Associates Pty Ltd | sidrasolutions.com

Organisation: AJW | Licence: NETWORK / 1PC | Processed: Friday, 27 March 2026 5:58:18 pm

Project: C:\Users\lannaj\OneDrive\AW Consulting\Projects\Boffa Miskell Jobs\Wairakei South\ITA Work Feb 2026\Final SIDRA Modelling\Third Round Base Sidra File\2048_TTHM 10B Mitigated.sip9

MOVEMENT SUMMARY

 Site: 101 [1348 Bell Rd Parton Rd PM (Site Folder: General)]

Output produced by SIDRA INTERSECTION Version: 9.1.6.228

 Network: N101
[2048_Opt10B_PM (Network Folder: General)]

New Site
Site Category: (None)
Stop (Two-Way)

Vehicle Movement Performance															
Mov ID	Turn	Mov Class	Demand Flows		Arrival Flows		Deg. Satn	Aver. Delay	Level of Service	Aver. Back of Queue	Prop. Que	Eff. Stop Rate	Aver. No. of Cycles	Aver. Speed	
			[Total HV] veh/h	%	[Total HV] veh/h	%									v/c
East: Bell Road															
5	T1	All MCs	413	3.9	411	3.9	0.216	0.1	LOS A	0.0	0.0	0.00	0.00	0.00	99.9
6	R2	All MCs	155	3.9	154	3.9	0.171	10.9	LOS B	0.3	2.2	0.59	0.80	0.59	87.5
Approach			567	3.9	565	3.9	0.216	3.0	NA	0.3	2.2	0.16	0.22	0.16	95.7
North: Parton Road															
7	L2	All MCs	152	3.9	152	3.9	0.185	12.7	LOS B	0.3	2.2	0.53	0.94	0.53	62.1
9	R2	All MCs	134	3.9	134	3.9	0.260	16.2	LOS C	0.4	2.8	0.72	1.02	0.82	55.9
Approach			285	3.9	285	3.9	0.260	14.3	LOS B	0.4	2.8	0.62	0.98	0.67	59.0
West: Bell Road															
10	L2	All MCs	128	3.9	128	3.9	0.325	8.0	LOS A	0.0	0.0	0.00	0.14	0.00	84.5
11	T1	All MCs	483	3.9	483	3.9	0.325	0.0	LOS A	0.0	0.0	0.00	0.14	0.00	93.7
Approach			612	3.9	612	3.9	0.325	1.7	NA	0.0	0.0	0.00	0.14	0.00	90.6
All Vehicles			1464	3.9	1462	3.9	0.325	4.7	NA	0.4	2.8	0.18	0.33	0.19	91.0

Site Level of Service (LOS) Method: Delay (SIDRA). Site LOS Method is specified in the Network Data dialog (Override Site Data tab).

Vehicle movement LOS values are based on average delay per movement.

Minor Road Approach LOS values are based on average delay for all vehicle movements.

NA (TWSC): Level of Service is not defined for major road approaches or the intersection as a whole for Two-Way Sign Control (HCM LOS rule).

Two-Way Sign Control Capacity Model: SIDRA Standard.

Delay Model: SIDRA Standard (Control Delay: Geometric Delay is included).

Queue Model: SIDRA queue estimation methods are used for Back of Queue and Queue at Start of Gap.

Gap-Acceptance Capacity Formula: SIDRA Standard (Akçelik M3D).

HV (%) values are calculated for All Movement Classes of All Heavy Vehicle Model Designation.

Arrival Flows used in performance calculations are adjusted to include any Initial Queued Demand and Upstream Capacity Constraint effects.

SIDRA INTERSECTION 9.1 | Copyright © 2000-2024 Akcelik and Associates Pty Ltd | sidrasolutions.com

Organisation: AJW | Licence: NETWORK / 1PC | Processed: Friday, 27 March 2026 5:58:18 pm

Project: C:\Users\anna\OneDrive\AW Consulting\Projects\Boffa Miskell Jobs\Wairakei South\ITA Work Feb 2026\Final SIDRA Modelling\Third Round Base Sidra File\2048_TTHM 10B Mitigated.sip9

USER REPORT FOR NETWORK SITE

Project: 2048_TTHM 10B Mitigated_v1

Template: Default Site User Report

 Site: 101 [1348 Bell Rd Parton Rd PM (Site Folder: General)]

 Network: 2 [2048_Opt10B_PM (Network Folder: General)]

New Site
Site Category: (None)
Stop (Two-Way)

Site Layout

Layout pictures are schematic functional drawings reflecting input data. They are not design drawings.

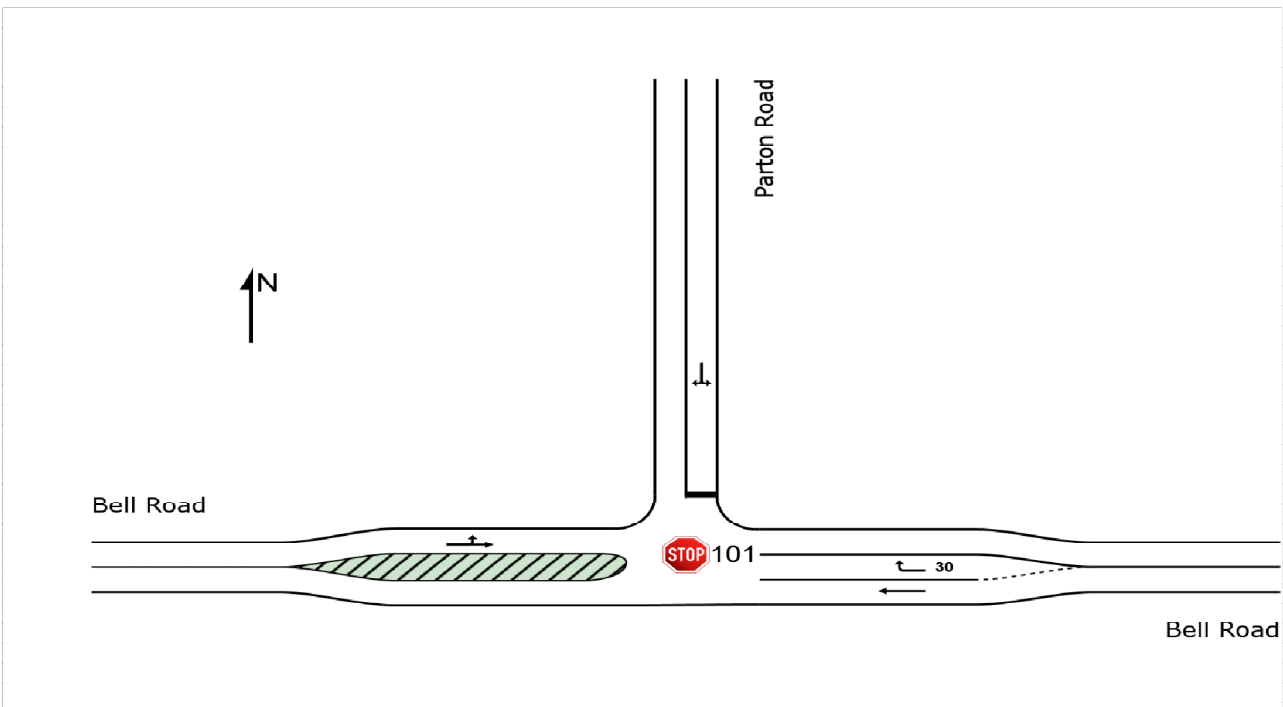

SIDRA INTERSECTION 9.1 | Copyright © 2000-2024 Akcelik and Associates Pty Ltd | sidrasolutions.com

Organisation: BOFFA MISKELL | Licence: NETWORK / 1PC | Created: Thursday, 23 April 2026 3:01:32 pm

Project: U:\2025\BM250088_BSa_Wairakei_South_Masterplan\Documents\Transport\Modelling\Sidra Network\260328 Sidra Models for ITA from Anna\2048_TTHM 10B Mitigated_v1.sip9

MOVEMENT SUMMARY

 Site: 101 [1348 Bell Rd Parton Rd PM (Site Folder: General)]

Output produced by SIDRA INTERSECTION Version: 9.1.6.228

 Network: N101
[2048_Opt10B_PM (Network Folder: General)]

New Site
Site Category: (None)
Stop (Two-Way)

Vehicle Movement Performance															
Mov ID	Turn	Mov Class	Demand Flows		Arrival Flows		Deg. Satn	Aver. Delay	Level of Service	Aver. Back Of Queue	Prop. Que	Eff. Stop Rate	Aver. No. of Cycles	Aver. Speed	
			[Total HV] veh/h	%	[Total HV] veh/h	%									v/c
East: Bell Road															
5	T1	All MCs	413	3.9	411	3.9	0.216	0.1	LOS A	0.0	0.0	0.00	0.00	0.00	99.9
6	R2	All MCs	155	3.9	154	3.9	0.171	10.6	LOS B	0.3	2.2	0.59	0.81	0.59	87.6
Approach			567	3.9	565	3.9	0.216	3.0	NA	0.3	2.2	0.16	0.22	0.16	95.8
North: Parton Road															
7	L2	All MCs	152	3.9	152	3.9	0.445	14.4	LOS B	1.0	7.0	0.68	1.05	0.98	55.9
9	R2	All MCs	134	3.9	134	3.9	0.445	18.3	LOS C	1.0	7.0	0.68	1.05	0.98	55.9
Approach			285	3.9	285	3.9	0.445	16.2	LOS C	1.0	7.0	0.68	1.05	0.98	55.9
West: Bell Road															
10	L2	All MCs	128	3.9	128	3.9	0.325	8.0	LOS A	0.0	0.0	0.00	0.14	0.00	84.4
11	T1	All MCs	483	3.9	483	3.9	0.325	0.0	LOS A	0.0	0.0	0.00	0.14	0.00	93.6
Approach			612	3.9	612	3.9	0.325	1.7	NA	0.0	0.0	0.00	0.14	0.00	90.5
All Vehicles			1464	3.9	1462	3.9	0.445	5.0	NA	1.0	7.0	0.20	0.35	0.25	90.5

Site Level of Service (LOS) Method: Delay (SIDRA). Site LOS Method is specified in the Network Data dialog (Override Site Data tab).

Vehicle movement LOS values are based on average delay per movement.

Minor Road Approach LOS values are based on average delay for all vehicle movements.

NA (TWSC): Level of Service is not defined for major road approaches or the intersection as a whole for Two-Way Sign Control (HCM LOS rule).

Two-Way Sign Control Capacity Model: SIDRA Standard.

Delay Model: SIDRA Standard (Control Delay: Geometric Delay is included).

Queue Model: SIDRA queue estimation methods are used for Back of Queue and Queue at Start of Gap.

Gap-Acceptance Capacity Formula: SIDRA Standard (Akçelik M3D).

HV (%) values are calculated for All Movement Classes of All Heavy Vehicle Model Designation.

Arrival Flows used in performance calculations are adjusted to include any Initial Queued Demand and Upstream Capacity Constraint effects.

SIDRA INTERSECTION 9.1 | Copyright © 2000-2024 Akcelik and Associates Pty Ltd | sidrasolutions.com

Organisation: BOFFA MISKELL | Licence: NETWORK / 1PC | Processed: Saturday, 28 March 2026 3:26:55 pm

Project: U:\2025\BM250088_BSa_Wairakei_South_Masterplan\Documents\Transport\Modelling\Sidra Network\260328 Sidra Models for ITA from Anna\2048_TTHM 10B Mitigated_v1.sip9

MOVEMENT SUMMARY

Site: 2140p [2140 Te Puke Hwy Bell Rd PM Signals (Site Folder: General)]

Output produced by SIDRA INTERSECTION Version: 9.1.6.228

Network: N101
[2048_Opt10B_PM (Network Folder: General)]

New Site

Site Category: (None)

Signals - EQUISAT (Fixed-Time/SCATS) Isolated Cycle Time = 50 seconds (Site Practical Cycle Time)

Vehicle Movement Performance															
Mov ID	Turn	Mov Class	Demand Flows		Arrival Flows		Deg. Satn	Aver. Delay	Level of Service	Aver. Back Of Queue	Prop. Que	Eff. Stop Rate	Aver. No. of Cycles	Aver. Speed	
			[Total HV] veh/h	%	[Total HV] veh/h	%									v/c
South: Te Puke Hwy															
2	T1	All MCs	617	4.5	617	4.5	0.543	6.5	LOS A	5.5	40.3	0.64	0.57	0.64	98.9
3	R2	All MCs	237	4.5	237	4.5	*0.731	32.0	LOS C	3.8	27.5	1.00	0.87	1.19	94.4
Approach			854	4.5	854	4.5	0.731	13.6	LOS B	5.5	40.3	0.74	0.65	0.79	97.6
East: Bell Road															
4	L2	All MCs	316	4.5	315	4.5	0.309	13.1	LOS B	2.1	15.0	0.57	0.75	0.57	96.7
6	R2	All MCs	229	4.5	229	4.5	*0.794	34.8	LOS C	3.9	28.0	1.00	0.92	1.33	51.3
Approach			545	4.5	543	4.5	0.794	22.2	LOS C	3.9	28.0	0.75	0.82	0.89	92.4
North: Te Puke Hwy															
7	L2	All MCs	374	4.5	374	4.5	0.307	10.9	LOS B	1.7	12.6	0.45	0.73	0.45	63.0
8	T1	All MCs	681	4.5	681	4.5	*0.804	20.0	LOS C	7.4	53.7	0.93	0.85	1.09	96.6
Approach			1055	4.5	1055	4.5	0.804	16.8	LOS B	7.4	53.7	0.76	0.81	0.86	95.6
All Vehicles			2454	4.5	2452	4.5	0.804	16.9	LOS B	7.4	53.7	0.75	0.76	0.84	95.9

Site Level of Service (LOS) Method: Delay (SIDRA). Site LOS Method is specified in the Network Data dialog (Override Site Data tab).

Vehicle movement LOS values are based on average delay per movement.

Intersection and Approach LOS values are based on average delay for all vehicle movements.

Delay Model: SIDRA Standard (Control Delay: Geometric Delay is included).

Queue Model: SIDRA queue estimation methods are used for Back of Queue and Queue at Start of Green.

Gap-Acceptance Capacity Formula: SIDRA Standard (Akçelik M3D).

HV (%) values are calculated for All Movement Classes of All Heavy Vehicle Model Designation.

Arrival Flows used in performance calculations are adjusted to include any Initial Queued Demand and Upstream Capacity Constraint effects.

* Critical Movement (Signal Timing)

SIDRA INTERSECTION 9.1 | Copyright © 2000-2024 Akcelik and Associates Pty Ltd | sidrasolutions.com

Organisation: AJW | Licence: NETWORK / 1PC | Processed: Friday, 27 March 2026 5:58:18 pm

Project: C:\Users\annaj\OneDrive\AW Consulting\Projects\Boffa Miskell Jobs\Wairakei South\ITA Work Feb 2026\Final SIDRA Modelling\Third Round Base Sidra File\2048_TTHM 10B Mitigated.sip9

CCG PHASING SUMMARY

Common Control Group: CCG1 [CCG_PM1]

Output produced by SIDRA INTERSECTION Version: 9.1.6.228

Network: N101
[2048_Opt10B_PM (Network Folder: General)]

EQUISAT (Fixed-Time/SCATS) Coordinated Cycle Time = 130 seconds (Network Optimum Cycle Time - Minimum Delay)

Timings based on settings in the Network Timing dialog
 Phase Times determined by the program
 Downstream lane blockage effects included in determining phase times
 Green Split Priority has been specified
 Phase Sequence: CCG Phasing
 Input Phase Sequence: A, B, C, D
 Output Phase Sequence: A, B, C, D
 Reference Phase: Phase A
 Offset: 0 seconds (Program)

Phase Timing Summary (CCG)

Phase	A	B	C	D
Phase Change Time (sec)	0	42	62	91
Green Time (sec)	36	14	23	33
Phase Time (sec)	42	20	29	39
Phase Split	32%	15%	22%	30%
Phase Frequency (%)	100.0	100.0	100.0	100.0

See the Timing Analysis report for more detailed information including input values of Yellow Time and All-Red Time, and information on any adjustments to Intergreen Time, Phase Time and Green Time values in cases of Pedestrian Actuation, Minor Phase Actuation and Phase Frequency values (user-specified or implied) less than 100%.

Output Phase Sequence (CCG)

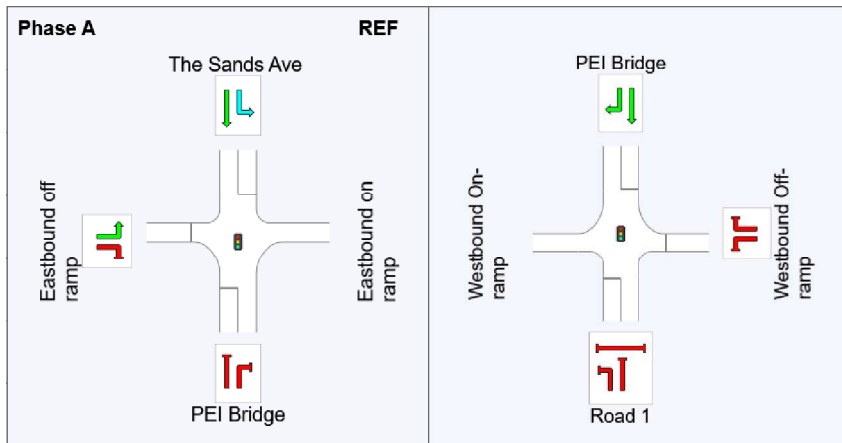

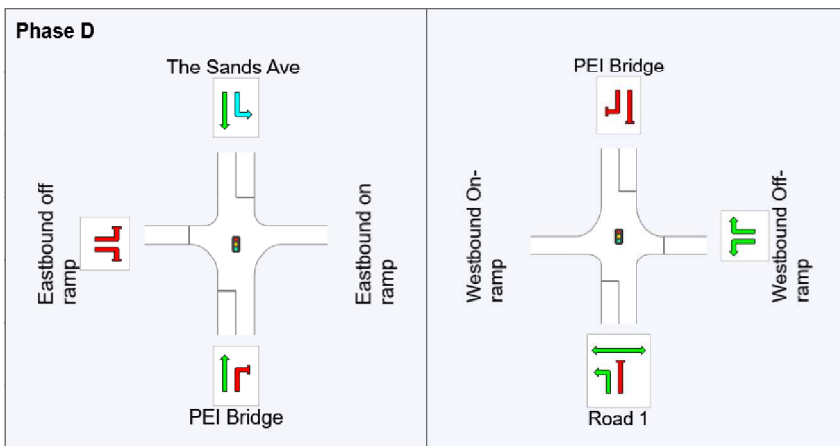
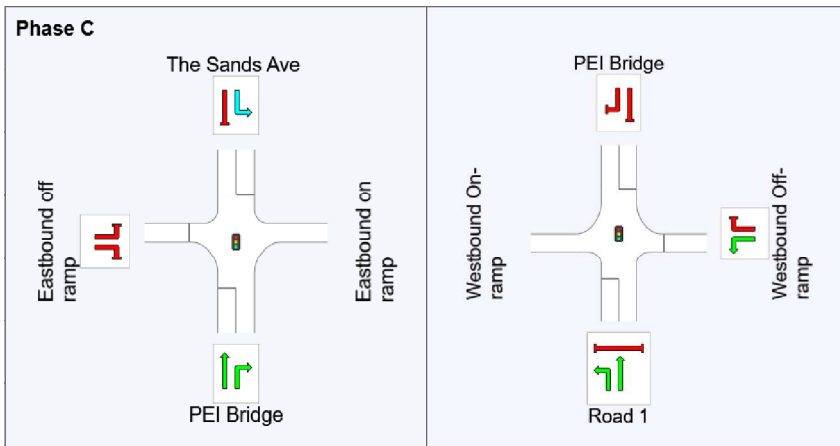
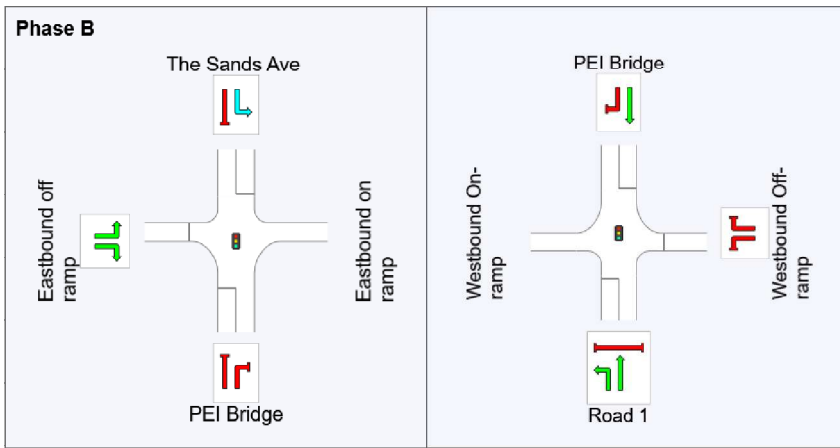

REF: Reference Phase
 VAR: Variable Phase



PHASING SUMMARY

Site: 2859p [2859 Boulv_TheSand_PM (Site Folder: General)]

Output produced by SIDRA INTERSECTION Version: 9.1.6.228

Network: N101
[2048_Opt10B_PM (Network Folder: General)]

Site Category: (None)

Signals - EQUISAT (Fixed-Time/SCATS) Coordinated Cycle Time = 130 seconds (Network Optimum Cycle Time - Minimum Delay)

Timings based on settings in the Network Timing dialog

Phase Times determined by the program

Downstream lane blockage effects included in determining phase times

Green Split Priority has been specified

Phase Sequence: DDO - Copy

Input Phase Sequence: A, B*, D, D1*, E, F, F1*, C*

Output Phase Sequence: A, B*, D, D1*, E, F, F1*

Reference Phase: Phase A

Offset: 58 seconds (Program)

(* Variable Phase)

Phase Timing Summary

Phase	A	B	D	D1	E	F	F1
Phase Change Time (sec)	62	80	99	111	9	23	52
Green Time (sec)	16	13	6	22	8	23	4
Phase Time (sec)	22	19	12	28	14	29	6
Phase Split	17%	15%	9%	22%	11%	22%	5%
Phase Frequency (%)	100.0	100.0	100.0	100.0	100.0	100.0	25.8 ³

See the Timing Analysis report for more detailed information including input values of Yellow Time and All-Red Time, and information on any adjustments to Intergreen Time, Phase Time and Green Time values in cases of Pedestrian Actuation, Minor Phase Actuation and Phase Frequency values (user-specified or implied) less than 100%.

³ Phase Frequency has been estimated from actuated movement probabilities.

Output Phase Sequence

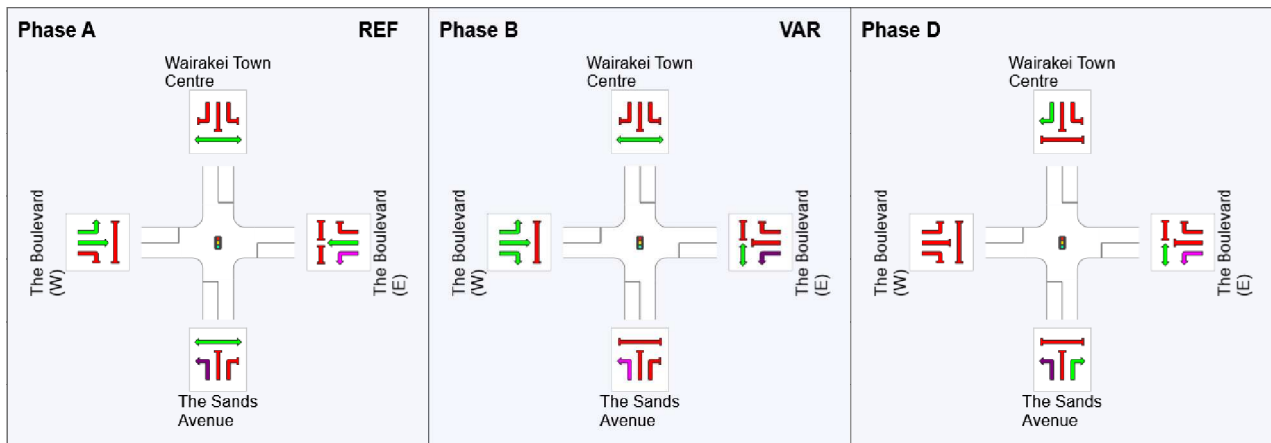

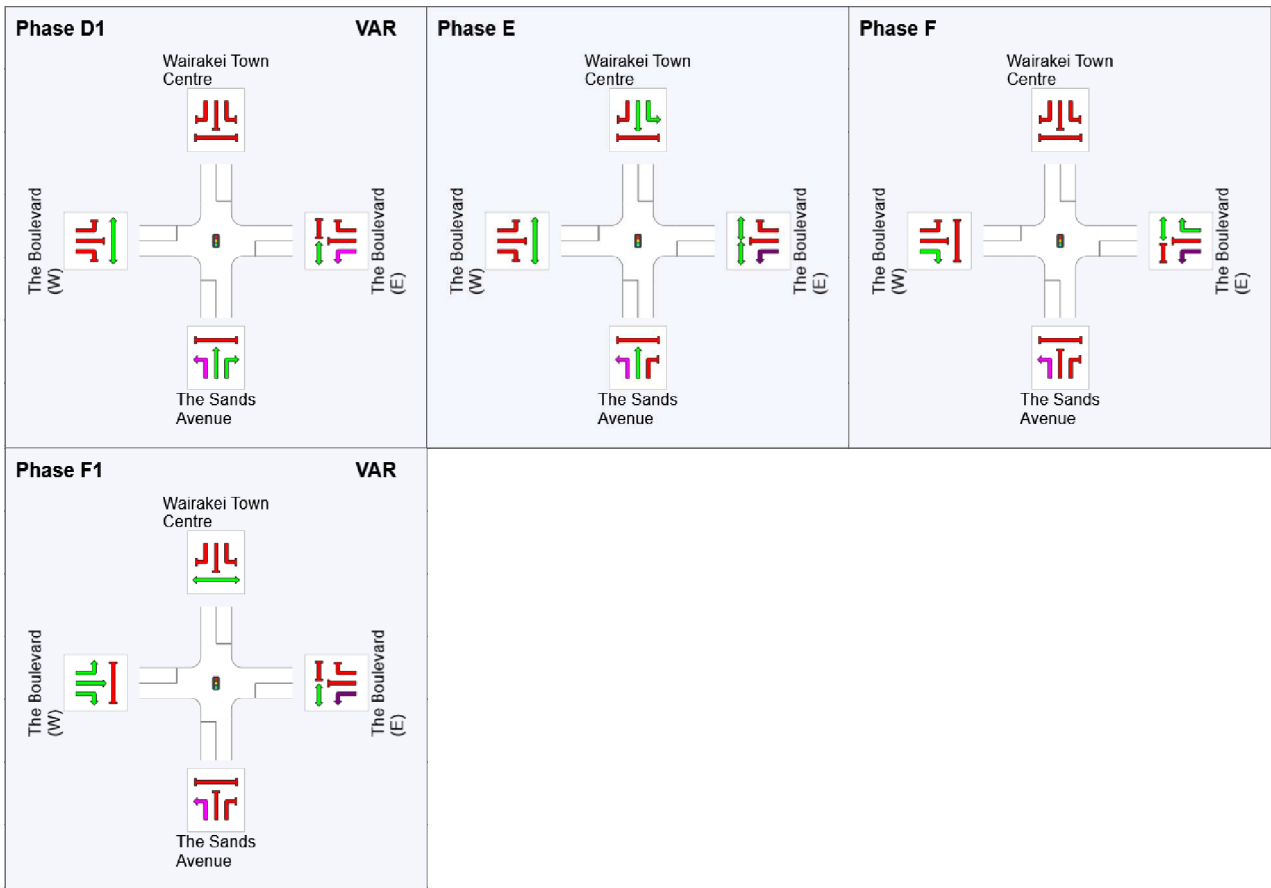

REF: Reference Phase
 VAR: Variable Phase

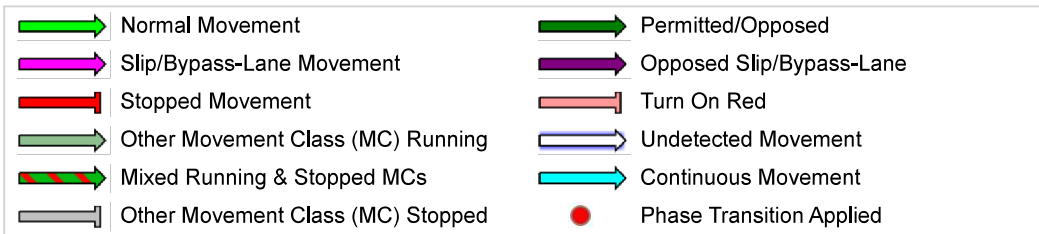

SIDRA INTERSECTION 9.1 | Copyright © 2000-2024 Akcelik and Associates Pty Ltd | sidrasolutions.com

Organisation: AJW | Licence: NETWORK / 1PC | Processed: Friday, 27 March 2026 5:58:18 pm

Project: C:\Users\anna\OneDrive\AW Consulting\Projects\Boffa Miskell Jobs\Wairakei South\ITA Work Feb 2026\Final SIDRA Modelling\Third Round Base Sidra File\2048_TTHM 10B Mitigated.sip9

PHASING SUMMARY

Site: 2860p [2860 The Sand_Bill Miller_PM (Site Folder: General)]

Output produced by SIDRA INTERSECTION Version: 9.1.6.228

Network: N101
[2048_Opt10B_PM (Network Folder: General)]

Site Category: (None)

Signals - EQUISAT (Fixed-Time/SCATS) Coordinated Cycle Time = 130 seconds (Network Optimum Cycle Time - Minimum Delay)

Timings based on settings in the Network Timing dialog

Phase Times determined by the program

Downstream lane blockage effects included in determining phase times

Green Split Priority has been specified

Phase Sequence: DDO - Copy

Input Phase Sequence: A, D, E, F

Output Phase Sequence: A, D, E, F

Reference Phase: Phase A

Offset: 95 seconds (Program)

Phase Timing Summary

Phase	A	D	E	F
Phase Change Time (sec)	95	49	61	83
Green Time (sec)	78	6	16	6
Phase Time (sec)	84	12	22	12
Phase Split	65%	9%	17%	9%
Phase Frequency (%)	100.0	100.0	100.0	100.0

See the Timing Analysis report for more detailed information including input values of Yellow Time and All-Red Time, and information on any adjustments to Intergreen Time, Phase Time and Green Time values in cases of Pedestrian Actuation, Minor Phase Actuation and Phase Frequency values (user-specified or implied) less than 100%.

Output Phase Sequence

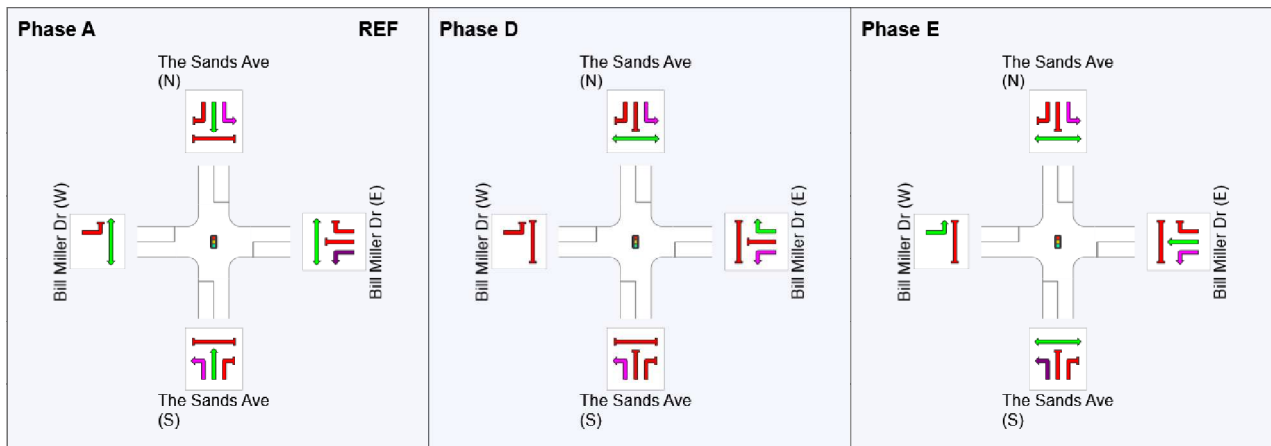

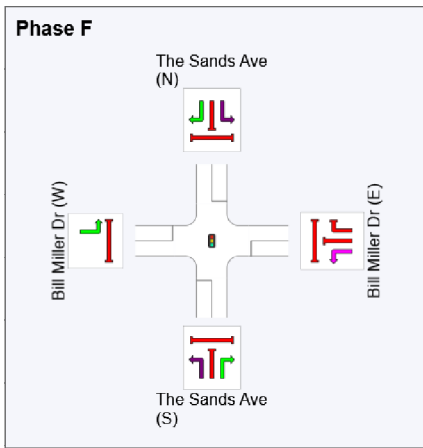

REF: Reference Phase

VAR: Variable Phase



SIDRA INTERSECTION 9.1 | Copyright © 2000-2024 Kcelik and Associates Pty Ltd | sidrasolutions.com

Organisation: AJW | Licence: NETWORK / 1PC | Processed: Friday, 27 March 2026 5:58:18 pm

Project: C:\Users\annaj\OneDrive\AW Consulting\Projects\Boffa Miskell Jobs\Wairakei South\ITA Work Feb 2026\Final SIDRA Modelling\Third Round Base Sidra File\2048_TTHM 10B Mitigated.sip9

PHASING SUMMARY

Site: 2514p [2514 Sands_Te Okuroa_PM (Site Folder: General)]

Output produced by SIDRA INTERSECTION Version: 9.1.6.228

Network: N101
[2048_Opt10B_PM (Network Folder: General)]

Site Category: (None)

Signals - EQUISAT (Fixed-Time/SCATS) Coordinated Cycle Time = 130 seconds (Network Optimum Cycle Time - Minimum Delay)

Timings based on settings in the Network Timing dialog

Phase Times determined by the program

Downstream lane blockage effects included in determining phase times

Green Split Priority has been specified

Phase Sequence: Variable Phasing

Input Phase Sequence: A, D, E, F, G

Output Phase Sequence: A, D, E, F, G

Reference Phase: Phase A

Offset: 100 seconds (Program)

Phase Timing Summary

Phase	A	D	E	F	G
Phase Change Time (sec)	100	23	45	71	83
Green Time (sec)	47	16	20	6	11
Phase Time (sec)	53	22	26	12	17
Phase Split	41%	17%	20%	9%	13%
Phase Frequency (%)	100.0	100.0	100.0	100.0	100.0

See the Timing Analysis report for more detailed information including input values of Yellow Time and All-Red Time, and information on any adjustments to Intergreen Time, Phase Time and Green Time values in cases of Pedestrian Actuation, Minor Phase Actuation and Phase Frequency values (user-specified or implied) less than 100%.

Output Phase Sequence

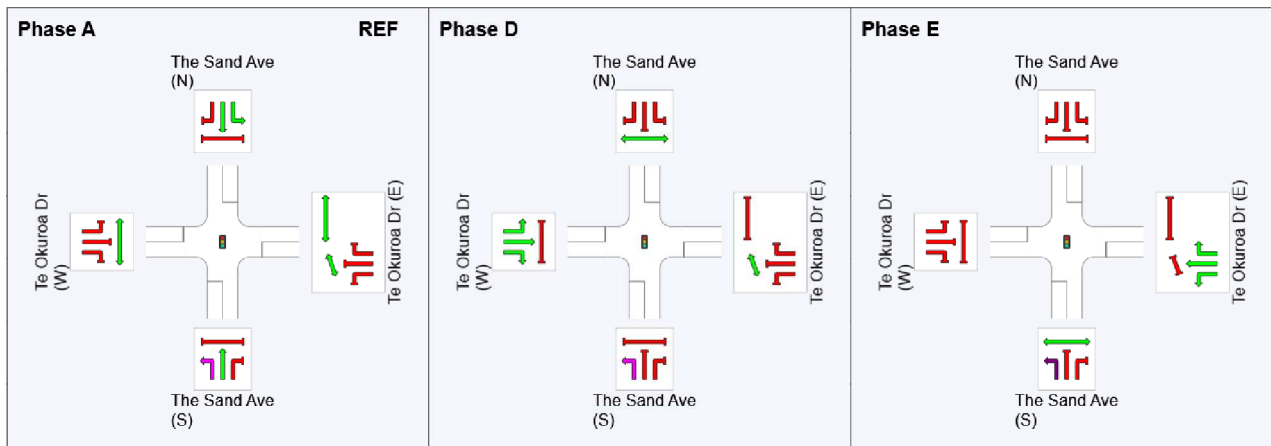

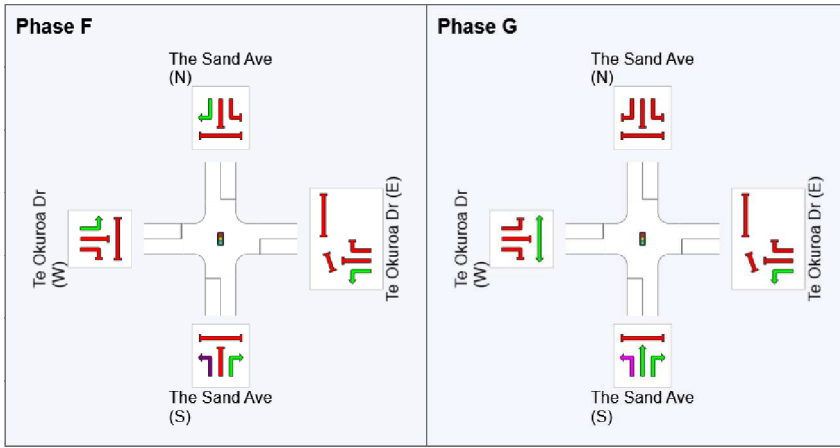

REF: Reference Phase
 VAR: Variable Phase



SIDRA INTERSECTION 9.1 | Copyright © 2000-2024 Akcelik and Associates Pty Ltd | sidrasolutions.com

Organisation: AJW | Licence: NETWORK / 1PC | Processed: Friday, 27 March 2026 5:58:18 pm

Project: C:\Users\annaj\OneDrive\AW Consulting\Projects\Boffa Miskell Jobs\Wairakei South\ITA Work Feb 2026\Final SIDRA Modelling\Third Round Base Sidra File\2048_TTHM 10B Mitigated.sip9

PHASING SUMMARY

Site: 10003p [10003_PM (Site Folder: General)]

Output produced by SIDRA INTERSECTION Version: 9.1.6.228

Network: N101
[2048_Opt10B_PM (Network Folder: General)]

NA

Site Category: (None)

Signals - EQUISAT (Fixed-Time/SCATS) Isolated Cycle Time = 100 seconds (Site Practical Cycle Time)

Timings based on settings in the Site Phasing & Timing dialog

Phase Times determined by the program

Downstream lane blockage effects included in determining phase times

Green Split Priority has been specified

Phase Sequence: Four-Phase Split Phasing

Input Phase Sequence: A, B, C, D

Output Phase Sequence: A, B, C, D

Reference Phase: Phase A

Offset: 0 seconds (User)

Phase Timing Summary







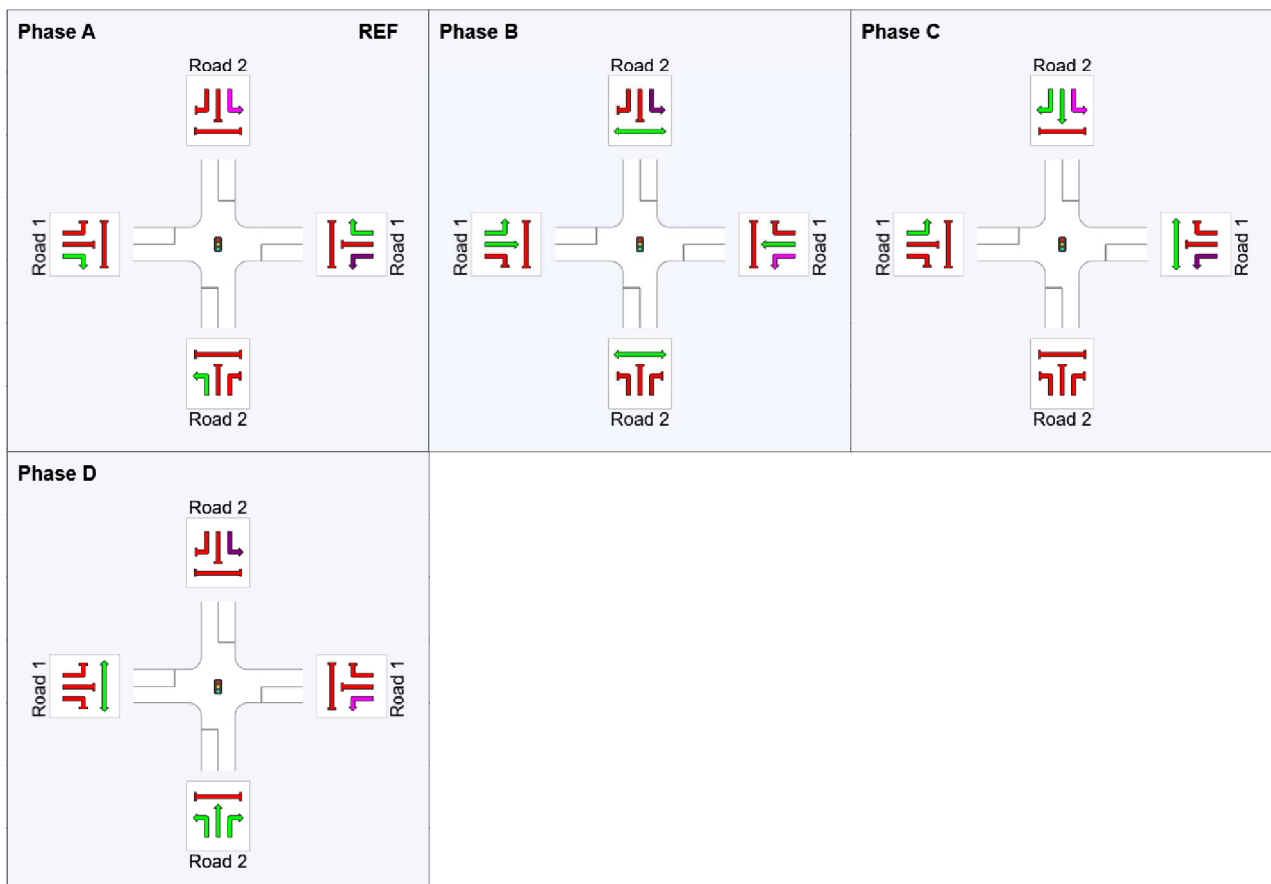





Phase	A	B	C	D
Phase Change Time (sec)	0	12	49	69
Green Time (sec)	6	31	14	25
Phase Time (sec)	12	37	20	31
Phase Split	12%	37%	20%	31%
Phase Frequency (%)	100.0	100.0	100.0	100.0

See the Timing Analysis report for more detailed information including input values of Yellow Time and All-Red Time, and information on any adjustments to Intergreen Time, Phase Time and Green Time values in cases of Pedestrian Actuation, Minor Phase Actuation and Phase Frequency values (user-specified or implied) less than 100%.

Output Phase Sequence



REF: Reference Phase
VAR: Variable Phase

	Normal Movement		Permitted/Opposed
	Slip/Bypass-Lane Movement		Opposed Slip/Bypass-Lane
	Stopped Movement		Turn On Red
	Other Movement Class (MC) Running		Undetected Movement
	Mixed Running & Stopped MCs		Continuous Movement
	Other Movement Class (MC) Stopped		Phase Transition Applied

SIDRA INTERSECTION 9.1 | Copyright © 2000-2024 Akcelik and Associates Pty Ltd | sidrasolutions.com

Organisation: AJW | Licence: NETWORK / 1PC | Processed: Friday, 27 March 2026 5:58:18 pm

Project: C:\Users\anna\OneDrive\AW Consulting\Projects\Boffa Miskell Jobs\Wairakei South\ITA Work Feb 2026\Final SIDRA Modelling\Third Round Base Sidra File\2048_TTHM 10B Mitigated.sip9

PHASING SUMMARY

Site: 10007p [10007_PM (Site Folder: General)]

Output produced by SIDRA INTERSECTION Version: 9.1.6.228

Network: N101
[2048_Opt10B_PM (Network Folder: General)]

NA

Site Category: (None)

Signals - EQUISAT (Fixed-Time/SCATS) Isolated Cycle Time = 70 seconds (Site Practical Cycle Time)

Timings based on settings in the Site Phasing & Timing dialog

Phase Times determined by the program

Downstream lane blockage effects included in determining phase times

Phase Sequence: Four-Phase Leading Right Turns

Input Phase Sequence: A, B, C, D

Output Phase Sequence: A, B, C, D

Reference Phase: Phase B

Offset: 0 seconds (User)

Phase Timing Summary







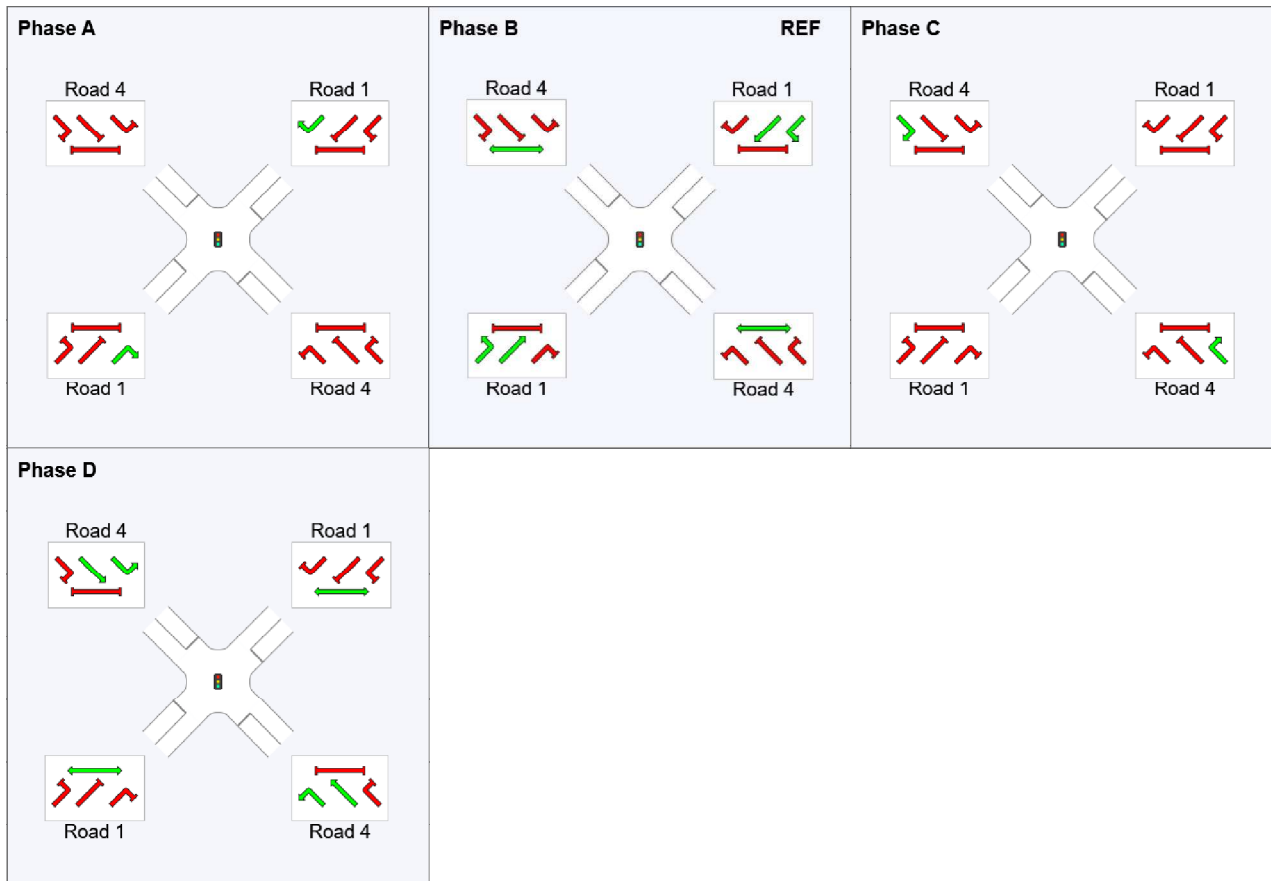

Phase	A	B	C	D
Phase Change Time (sec)	53	0	17	29
Green Time (sec)	11	11	6	18
Phase Time (sec)	17	17	12	24
Phase Split	24%	24%	17%	34%
Phase Frequency (%)	100.0	100.0	100.0	100.0

See the Timing Analysis report for more detailed information including input values of Yellow Time and All-Red Time, and information on any adjustments to Intergreen Time, Phase Time and Green Time values in cases of Pedestrian Actuation, Minor Phase Actuation and Phase Frequency values (user-specified or implied) less than 100%.

Output Phase Sequence



REF: Reference Phase
VAR: Variable Phase

	Normal Movement		Permitted/Opposed
	Slip/Bypass-Lane Movement		Opposed Slip/Bypass-Lane
	Stopped Movement		Turn On Red
	Other Movement Class (MC) Running		Undetected Movement
	Mixed Running & Stopped MCs		Continuous Movement
	Other Movement Class (MC) Stopped		Phase Transition Applied

PHASING SUMMARY

Site: 10008p [10008_PM (Site Folder: General)]

Output produced by SIDRA INTERSECTION Version: 9.1.6.228

Network: N101
[2048_Opt10B_PM (Network Folder: General)]

New Site

Site Category: (None)

Signals - EQUISAT (Fixed-Time/SCATS) Isolated Cycle Time = 70 seconds (Site Practical Cycle Time)

Timings based on settings in the Site Phasing & Timing dialog

Phase Times determined by the program

Downstream lane blockage effects included in determining phase times

Phase Sequence: Four-Phase Leading Right Turns

Input Phase Sequence: A, B, C, D

Output Phase Sequence: A, B, C, D

Reference Phase: Phase B

Offset: 0 seconds (User)

Phase Timing Summary







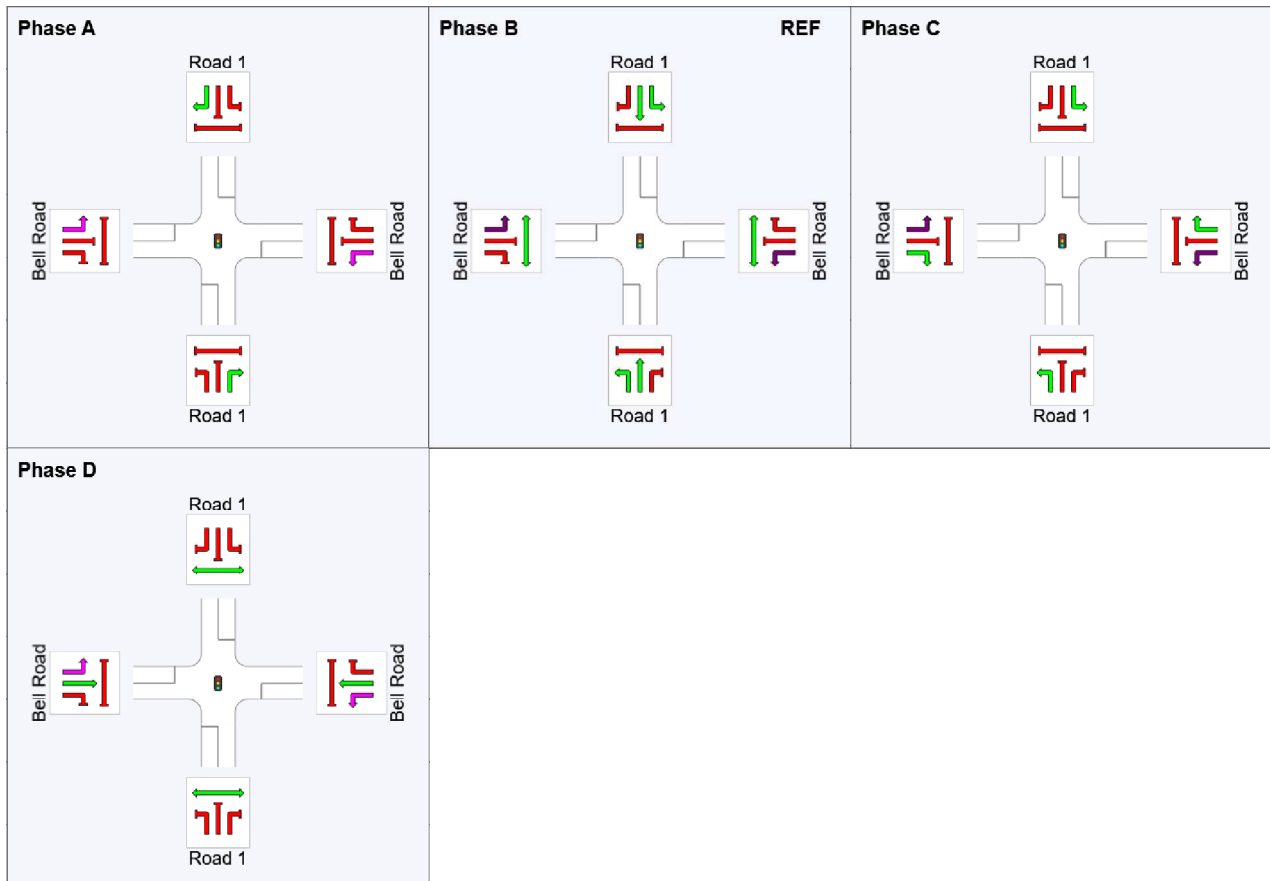



Phase	A	B	C	D
Phase Change Time (sec)	52	0	17	29
Green Time (sec)	12	11	6	17
Phase Time (sec)	18	17	12	23
Phase Split	26%	24%	17%	33%
Phase Frequency (%)	100.0	100.0	100.0	100.0

See the Timing Analysis report for more detailed information including input values of Yellow Time and All-Red Time, and information on any adjustments to Intergreen Time, Phase Time and Green Time values in cases of Pedestrian Actuation, Minor Phase Actuation and Phase Frequency values (user-specified or implied) less than 100%.

Output Phase Sequence



REF: Reference Phase
VAR: Variable Phase

	Normal Movement		Permitted/Opposed
	Slip/Bypass-Lane Movement		Opposed Slip/Bypass-Lane
	Stopped Movement		Turn On Red
	Other Movement Class (MC) Running		Undetected Movement
	Mixed Running & Stopped MCs		Continuous Movement
	Other Movement Class (MC) Stopped		Phase Transition Applied

PHASING SUMMARY

Site: 10015p [10015_PM (Site Folder: General)]

Output produced by SIDRA INTERSECTION Version: 9.1.6.228

Network: N101
[2048_Opt10B_PM (Network Folder: General)]

New Site

Site Category: (None)

Signals - EQUISAT (Fixed-Time/SCATS) Isolated Cycle Time = 70 seconds (Site Practical Cycle Time)

Timings based on settings in the Site Phasing & Timing dialog

Phase Times determined by the program

Downstream lane blockage effects included in determining phase times

Phase Sequence: Four-Phase Leading Right Turns

Input Phase Sequence: A, B, C, D

Output Phase Sequence: A, B, C, D

Reference Phase: Phase B

Offset: 0 seconds (User)

Phase Timing Summary







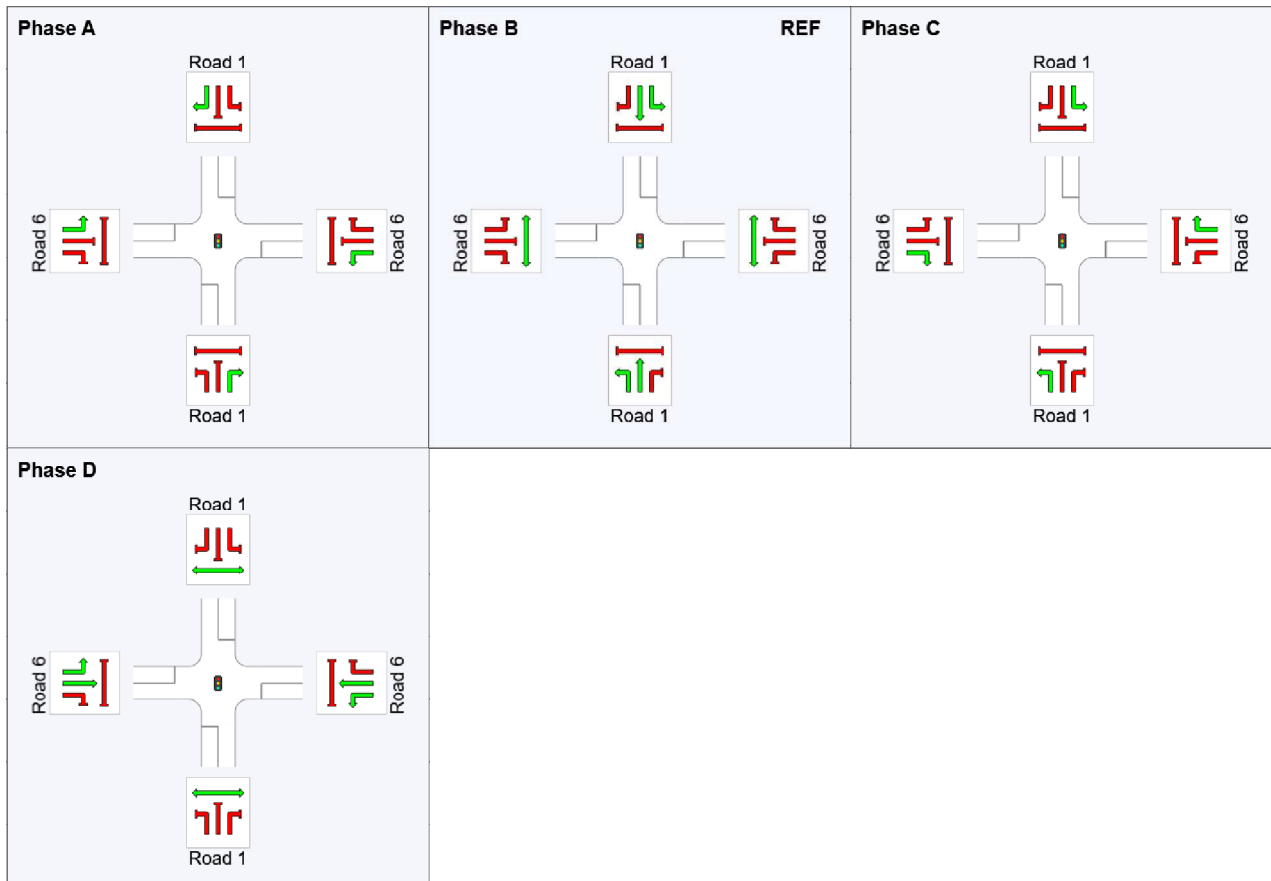

Phase	A	B	C	D
Phase Change Time (sec)	54	0	17	31
Green Time (sec)	10	11	8	17
Phase Time (sec)	16	17	14	23
Phase Split	23%	24%	20%	33%
Phase Frequency (%)	100.0	100.0	100.0	100.0

See the Timing Analysis report for more detailed information including input values of Yellow Time and All-Red Time, and information on any adjustments to Intergreen Time, Phase Time and Green Time values in cases of Pedestrian Actuation, Minor Phase Actuation and Phase Frequency values (user-specified or implied) less than 100%.

Output Phase Sequence



REF: Reference Phase
VAR: Variable Phase

	Normal Movement		Permitted/Opposed
	Slip/Bypass-Lane Movement		Opposed Slip/Bypass-Lane
	Stopped Movement		Turn On Red
	Other Movement Class (MC) Running		Undetected Movement
	Mixed Running & Stopped MCs		Continuous Movement
	Other Movement Class (MC) Stopped		Phase Transition Applied

PHASING SUMMARY

Site: 10016p [10016_PM (Site Folder: General)]

Output produced by SIDRA INTERSECTION Version: 9.1.6.228

Network: N101
[2048_Opt10B_PM (Network Folder: General)]

New Site

Site Category: (None)

Signals - EQUISAT (Fixed-Time/SCATS) Isolated Cycle Time = 60 seconds (Site Practical Cycle Time)

Timings based on settings in the Site Phasing & Timing dialog

Phase Times determined by the program

Downstream lane blockage effects included in determining phase times

Phase Sequence: Four-Phase Leading Right Turns

Input Phase Sequence: A, B, C, D

Output Phase Sequence: A, B, C, D

Reference Phase: Phase B

Offset: 0 seconds (User)

Phase Timing Summary







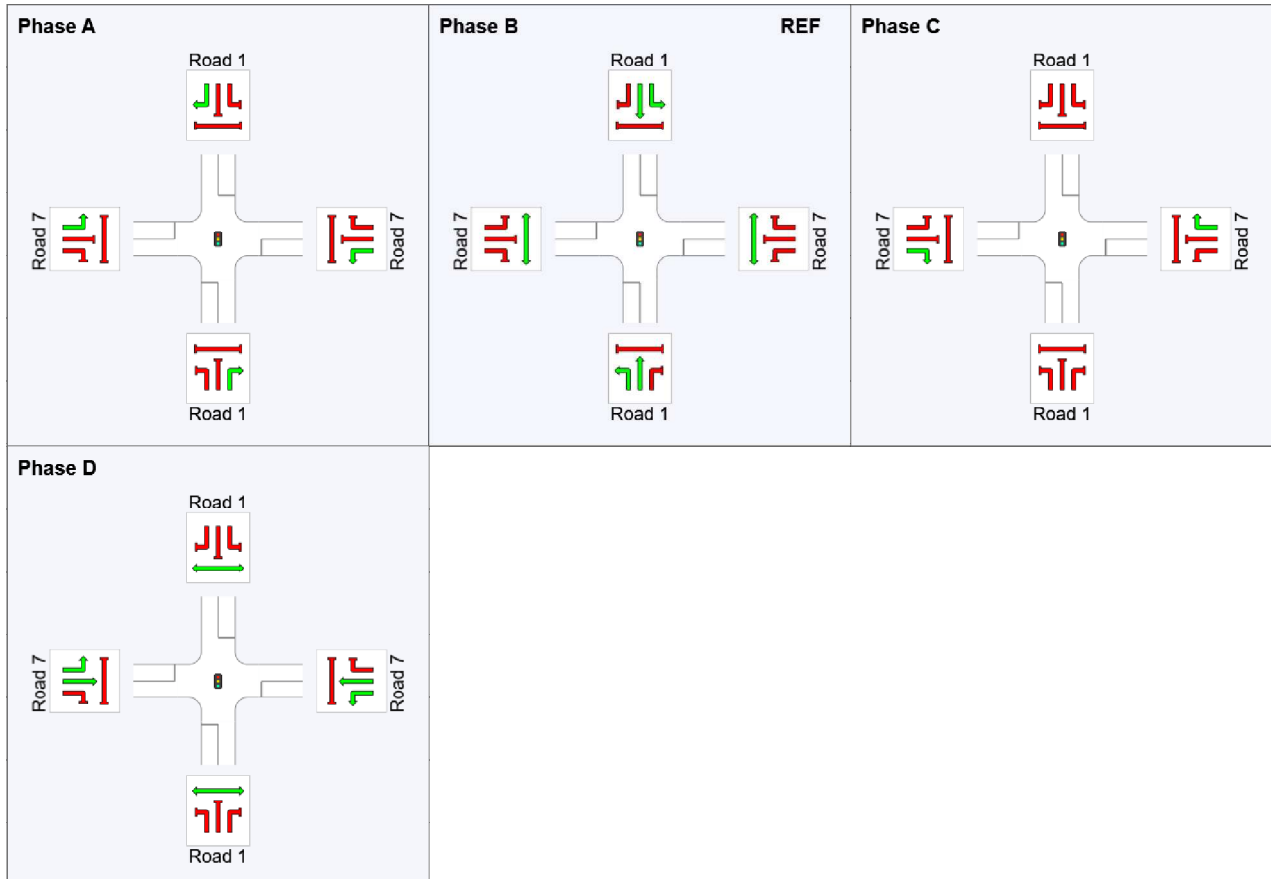

Phase	A	B	C	D
Phase Change Time (sec)	46	0	17	29
Green Time (sec)	8	11	6	11
Phase Time (sec)	14	17	12	17
Phase Split	23%	28%	20%	28%
Phase Frequency (%)	100.0	100.0	100.0	100.0

See the Timing Analysis report for more detailed information including input values of Yellow Time and All-Red Time, and information on any adjustments to Intergreen Time, Phase Time and Green Time values in cases of Pedestrian Actuation, Minor Phase Actuation and Phase Frequency values (user-specified or implied) less than 100%.

Output Phase Sequence



REF: Reference Phase
VAR: Variable Phase

	Normal Movement		Permitted/Opposed
	Slip/Bypass-Lane Movement		Opposed Slip/Bypass-Lane
	Stopped Movement		Turn On Red
	Other Movement Class (MC) Running		Undetected Movement
	Mixed Running & Stopped MCs		Continuous Movement
	Other Movement Class (MC) Stopped		Phase Transition Applied

PHASING SUMMARY

Site: 2140p [2140 Te Puke Hwy Bell Rd PM Signals (Site Folder: General)]

Output produced by SIDRA INTERSECTION Version: 9.1.6.228

Network: N101
[2048_Opt10B_PM (Network Folder: General)]

New Site
Site Category: (None)
Signals - EQUISAT (Fixed-Time/SCATS) Isolated Cycle Time = 50 seconds (Site Practical Cycle Time)

Timings based on settings in the Site Phasing & Timing dialog
Phase Times determined by the program
Downstream lane blockage effects included in determining phase times
Phase Sequence: Convert Function Default
Input Phase Sequence: A, B, C
Output Phase Sequence: A, B, C
Reference Phase: Phase B
Offset: 0 seconds (User)

Phase Timing Summary

Phase	A	B	C
Phase Change Time (sec)	35	0	21
Green Time (sec)	9	15	8
Phase Time (sec)	15	21	14
Phase Split	30%	42%	28%
Phase Frequency (%)	100.0	100.0	100.0

See the Timing Analysis report for more detailed information including input values of Yellow Time and All-Red Time, and information on any adjustments to Intergreen Time, Phase Time and Green Time values in cases of Pedestrian Actuation, Minor Phase Actuation and Phase Frequency values (user-specified or implied) less than 100%.

Output Phase Sequence

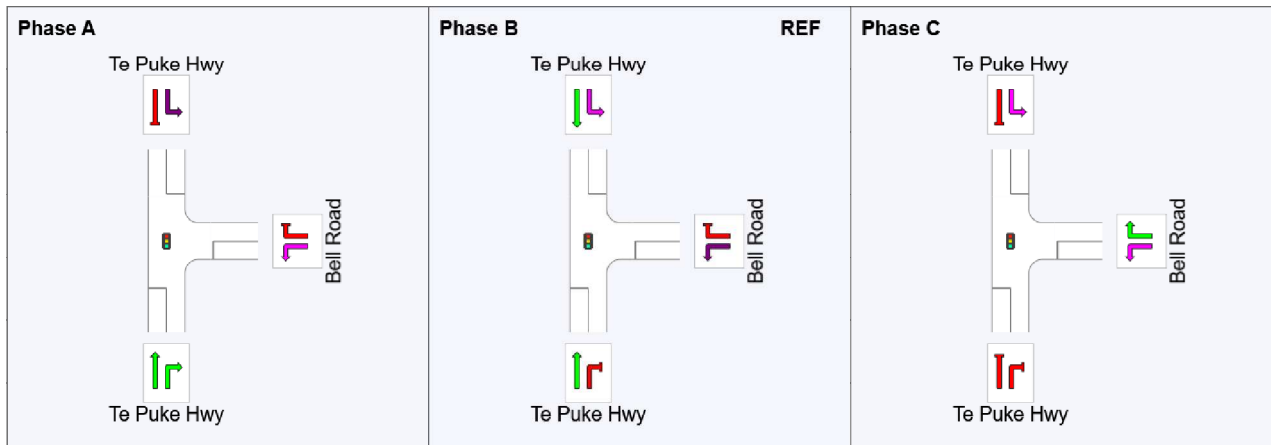

REF: Reference Phase
VAR: Variable Phase



SIGNAL OFFSETS

Network: N101 [2048_Opt10B_PM (Network Folder: General)]

Output produced by SIDRA INTERSECTION Version: 9.1.6.228

New Network

Network Category: (None)

Network Cycle Time = 130 seconds (Network Optimum Cycle Time - Minimum Delay)

SIGNAL OFFSETS

Offset Definition: Green Start

Reference Site / CCG: CCG1 [CCG_PM1]¹

Site ID	2440p ¹	2439p ¹	2514p	2860p	2859p
CCG ID (if applicable)	CCG1	CCG1	NA	NA	NA
Offset (sec)	0	0	100	95	58
Program / User	P	P	P	P	P
Reference Phase	A	A	A	A	A
Route ID	R103	R103	R103	R103	R103

¹ Reference Site / CCG as specified in the Network Timing dialog, Network Timing Data tab. This Site / CCG is included in the Route with the highest Offset Priority and is used in offset calculations.

ROUTE OFFSET RESULTS

Route ID: R103

Route Name: TEL WB Off to Sands N

Offset Priority: 1

Offset Method: Start of Green (Leading)

Movement Class for Offset Calculation: Light Vehicles

Site ID	2440p ¹	2439p ¹	2514p	2860p	2859p
Reference Phase	A	A	A	A	A
Offset (sec)	0	0	100	95	58
Calculated offset used (Yes / No)	Yes	Yes	Yes	Yes	Yes
Approach	E	S	S	S	S
Turn	R2	T1	T1	T1	T1
Stopline Travel Distance (m)	0.0	130.2	268.4	156.5	161.6
Stopline Travel Time (sec)	0	11	21	12	13
Start Phase of Movement	D	C	G	A	D1
Relative Offset - Phase (sec)	0	97	21	12	16
Relative Offset - Movement (sec)	0	0	21	12	16
Phase Change Time (sec)	91	62	83	95	111
Displayed Green Start Time (sec)	97	68	89	101	117
Displayed Green Time (sec)	33	62	64	78	36
Effective Green Start Time (sec)	100	71	92	104	120
Effective Green Time (sec)	33	62	64	78	36
Green Time Ratio	0.254	0.477	0.492	0.600	0.277
% Arriving During Green	25.4	71.8	52.7	93.0	68.6
Platoon Ratio	1.000	1.506	1.069	1.550	2.476
Equivalent AT	3	5	4	5	6
Average Delay (sec)	336.3	14.8	34.8	2.2	16.9
% Back of Queue - Distance (m)	391.9	115.0	180.9	35.1	24.8
% Back of Queue - Vehicles	52.6	15.4	24.3	4.8	3.4
Effective Stop Rate	1.76	0.61	0.83	0.15	0.38
Proportion Queued	1.00	0.68	0.89	0.17	0.46

Route ID: R105

Route Name: TEL EB Off to Sands N

Offset Priority: 2

Offset Method: Start of Green (Leading)

Movement Class for Offset Calculation: Light Vehicles

Site ID	2439p ¹	2514p	2860p	2859p
Reference Phase	A	A	A	A
Offset (sec)	0	100	95	58
Calculated offset used (Yes / No)	No	No	No	No

Approach	W	S	S	S
Turn	L2	T1	T1	T1
Stopline Travel Distance (m)	0.0	268.4	156.5	161.6
Stopline Travel Time (sec)	0	21	12	13
Start Phase of Movement	A	G	A	D1
Relative Offset - Phase (sec)	0	83	12	16
Relative Offset - Movement (sec)	0	83	12	16
Phase Change Time (sec)	0	83	95	111
Displayed Green Start Time (sec)	6	89	101	117
Displayed Green Time (sec)	56	64	78	36
Effective Green Start Time (sec)	9	92	104	120
Effective Green Time (sec)	56	64	78	36
Green Time Ratio	0.431	0.492	0.600	0.277
% Arriving During Green	43.1	52.7	93.0	68.6
Platoon Ratio	1.000	1.069	1.550	2.476
Equivalent AT	3	4	5	6
Average Delay (sec)	41.6	34.8	2.2	16.9
% Back of Queue - Distance (m)	159.3	180.9	35.1	24.8
% Back of Queue - Vehicles	21.4	24.3	4.8	3.4
Effective Stop Rate	0.90	0.83	0.15	0.38
Proportion Queued	0.94	0.89	0.17	0.46

Route ID: R104

Route Name: Sands SB

Offset Priority: 3

Offset Method: Start of Green (Leading)

Movement Class for Offset Calculation: Light Vehicles

Site ID	2859p	2860p	2514p	2439p ¹	2440p ¹
Reference Phase	A	A	A	A	A
Offset (sec)	58	95	100	0	0
Calculated offset used (Yes / No)	No	No	No	No	No
Approach	N	N	N	N	N
Turn	T1	T1	T1	T1	T1
Stopline Travel Distance (m)	0.0	170.3	149.4	274.6	129.0
Stopline Travel Time (sec)	0	15	12	22	10
Start Phase of Movement	E	A	A	D	A
Relative Offset - Phase (sec)	0	86	5	121	121
Relative Offset - Movement (sec)	0	86	5	121	121
Phase Change Time (sec)	9	95	100	91	0
Displayed Green Start Time (sec)	15	101	106	97	6
Displayed Green Time (sec)	8	78	47	75	56
Effective Green Start Time (sec)	18	104	109	100	9
Effective Green Time (sec)	8	78	47	75	56
Green Time Ratio	0.062	0.600	0.362	0.577	0.431
% Arriving During Green	6.2	54.8	48.3	63.3	58.1
Platoon Ratio	1.000	0.914	1.335	1.097	1.348
Equivalent AT	3	2	4	4	4
Average Delay (sec)	77.9	76.6	129.9	55.5	33.7
% Back of Queue - Distance (m)	16.8	145.0	132.0	183.1	115.0
% Back of Queue - Vehicles	2.3	19.8	17.7	24.5	15.4
Effective Stop Rate	0.93	1.25	1.51	1.11	0.93
Proportion Queued	1.00	1.00	1.00	0.97	0.94

¹ Reference Site / CCG as specified in the Network Timing dialog, Network Timing Data tab. This Site / CCG is included in the Route with the highest Offset Priority and is used in offset calculations.

SITE LAYOUT

 Site: 2122p [2122 TEL Te Puke Highway PM (Site Folder: General)]

New Site
Site Category: (None)
Roundabout

Layout pictures are schematic functional drawings reflecting input data. They are not design drawings.

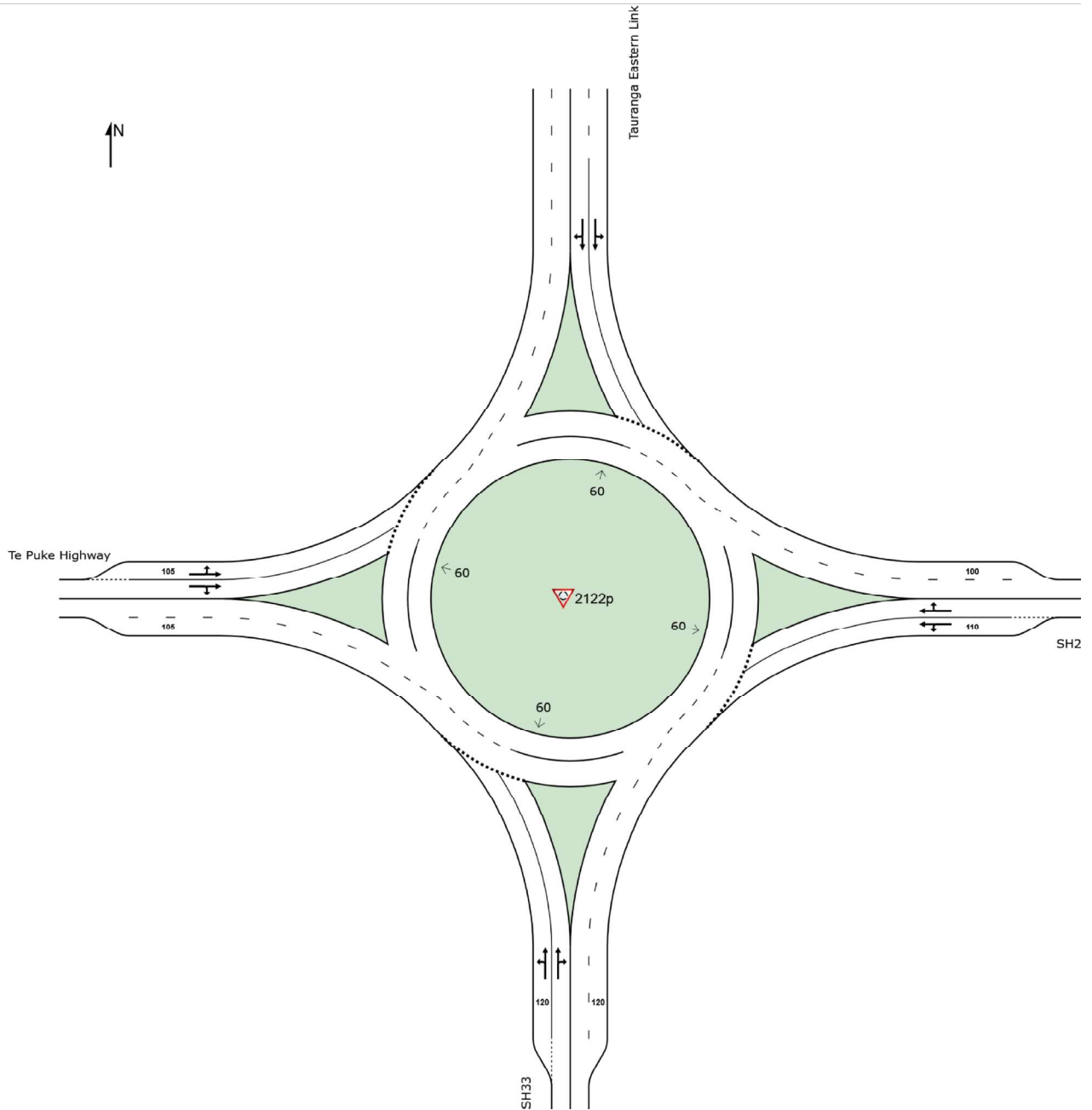

SIDRA INTERSECTION 9.1 | Copyright © 2000-2024 Akcelik and Associates Pty Ltd | sidrasolutions.com

Organisation: AJW | Licence: NETWORK / 1PC | Created: Friday, 27 March 2026 7:36:25 pm

Project: C:\Users\anna\OneDrive\AW Consulting\Projects\Boffa Miskell Jobs\Wairakei South\ITA Work Feb 2026\Final SIDRA Modelling\Third Round Base Sidra File\2048_TTHM 10B Mitigated.sip9

MOVEMENT SUMMARY

 Site: 2122p [2122 TEL Te Puke Highway PM (Site Folder: General)]

Output produced by SIDRA INTERSECTION Version: 9.1.6.228

New Site
Site Category: (None)
Roundabout

Vehicle Movement Performance															
Mov ID	Turn	Mov Class	Demand Flows		Arrival Flows		Deg. Satn	Aver. Delay	Level of Service	95% Back Of Queue		Prop. Que	Eff. Stop Rate	Aver. No. of Cycles	Aver. Speed
			[Total HV]	%	[Total HV]	%	v/c	sec		[Veh. veh	Dist] m				km/h
South: SH33															
1	L2	All MCs	153	9.7	153	9.7	0.627	11.4	LOS B	6.1	47.0	1.00	1.02	1.35	49.5
2	T1	All MCs	537	14.3	537	14.3	0.627	12.2	LOS B	6.1	47.0	0.98	1.02	1.34	43.1
3	R2	All MCs	1	0.0	1	0.0	0.627	20.1	LOS C	4.9	38.8	0.96	1.03	1.33	42.2
Approach			691	13.3	691	13.3	0.627	12.1	LOS B	6.1	47.0	0.98	1.02	1.34	48.1
East: SH2															
4	L2	All MCs	1	0.0	1	0.0	0.255	5.0	LOS A	1.4	10.0	0.72	0.53	0.72	46.5
5	T1	All MCs	181	6.4	181	6.4	0.255	4.3	LOS A	1.4	10.0	0.72	0.53	0.72	49.7
6	R2	All MCs	852	7.0	852	7.0	0.845	18.5	LOS B	12.8	95.1	0.99	1.20	1.70	40.4
Approach			1034	6.9	1034	6.9	0.845	16.0	LOS B	12.8	95.1	0.94	1.08	1.52	47.0
North: Tauranga Eastern Link															
7	L2	All MCs	646	10.3	646	10.3	0.572	2.9	LOS A	4.6	35.5	0.68	0.43	0.70	46.8
8	T1	All MCs	416	15.4	416	15.4	0.572	2.9	LOS A	4.6	35.5	0.69	0.51	0.74	45.9
9	R2	All MCs	239	12.8	239	12.8	0.572	9.9	LOS A	4.5	35.3	0.70	0.53	0.75	49.6
Approach			1301	12.4	1301	12.4	0.572	4.2	LOS A	4.6	35.5	0.69	0.47	0.72	48.9
West: Te Puke Highway															
10	L2	All MCs	151	23.1	151	23.1	0.449	11.7	LOS B	2.8	23.4	0.90	0.93	1.09	49.5
11	T1	All MCs	183	11.5	183	11.5	0.492	9.3	LOS A	4.0	31.1	0.95	0.92	1.15	49.5
12	R2	All MCs	169	14.9	169	14.9	0.492	15.4	LOS B	4.0	31.1	0.96	0.92	1.16	49.4
Approach			503	16.1	503	16.1	0.492	12.1	LOS B	4.0	31.1	0.94	0.92	1.13	49.5
All Vehicles			3528	11.5	3528	11.5	0.845	10.3	LOS B	12.8	95.1	0.86	0.82	1.14	48.6

Site Level of Service (LOS) Method: Delay (SIDRA). Site LOS Method is specified in the Parameter Settings dialog (Options tab).
 Roundabout LOS Method: SIDRA Roundabout LOS.
 Vehicle movement LOS values are based on average delay per movement.
 Intersection and Approach LOS values are based on average delay for all vehicle movements.
 Roundabout Capacity Model: SIDRA Standard.
 Delay Model: SIDRA Standard (Control Delay: Geometric Delay is included).
 Queue Model: SIDRA queue estimation methods are used for Back of Queue and Queue at Start of Gap.
 Gap-Acceptance Capacity Formula: SIDRA Standard (Akçelik M3D).
 HV (%) values are calculated for All Movement Classes of All Heavy Vehicle Model Designation.
 Arrival Flows used in performance calculations are adjusted to include any Initial Queued Demand and Upstream Capacity Constraint effects.

SITE LAYOUT

Site: 1335 [1335 Tara Rd Parton Rd RAB PM (Site Folder: General)]

New Site
Site Category: (None)
Roundabout

Layout pictures are schematic functional drawings reflecting input data. They are not design drawings.

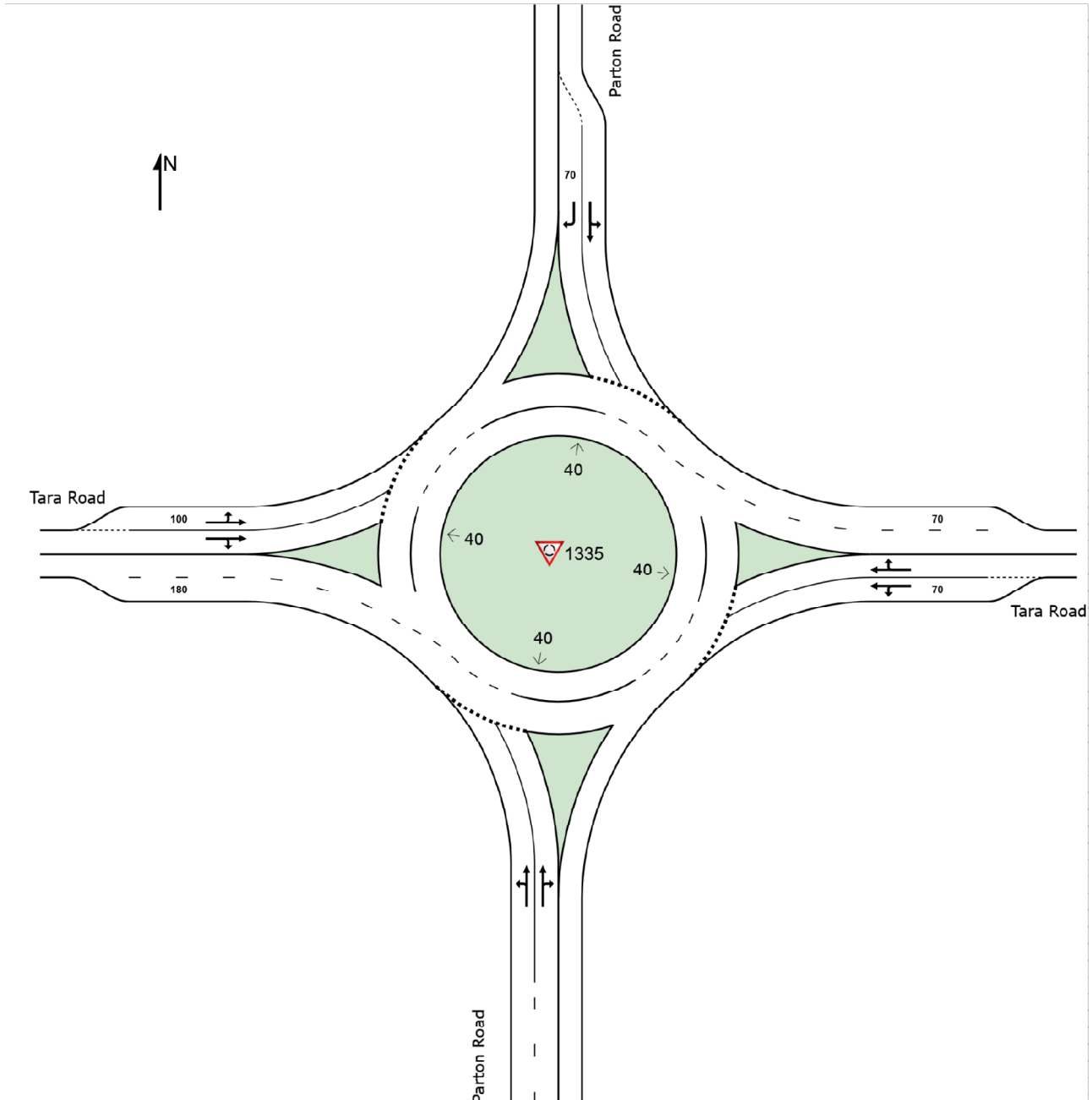

SIDRA INTERSECTION 9.1 | Copyright © 2000-2024 Akcelik and Associates Pty Ltd | sidrasolutions.com

Organisation: AJW | Licence: NETWORK / 1PC | Created: Friday, 27 March 2026 7:36:33 pm

Project: C:\Users\annaj\OneDrive\AW Consulting\Projects\Boffa Miskell Jobs\Wairakei South\ITA Work Feb 2026\Final SIDRA Modelling\Third Round Base Sidra File\2048_TTHM 10B Mitigated.sip9

MOVEMENT SUMMARY

 Site: 1335 [1335 Tara Rd Parton Rd RAB PM (Site Folder: General)]

Output produced by SIDRA INTERSECTION Version: 9.1.6.228

New Site
 Site Category: (None)
 Roundabout

Vehicle Movement Performance															
Mov ID	Turn	Mov Class	Demand Flows		Arrival Flows		Deg. Satn	Aver. Delay	Level of Service	95% Back Of Queue	Dist	Prop. Que	Eff. Stop Rate	Aver. No. of Cycles	Aver. Speed
			[Total HV]	%	[Total HV]	%	v/c	sec		[Veh. veh	m				km/h
South: Parton Road															
1	L2	All MCs	86	3.5	86	3.5	0.102	4.3	LOS A	0.4	2.9	0.52	0.56	0.52	50.2
2	T1	All MCs	63	3.5	63	3.5	0.171	2.8	LOS A	0.8	5.5	0.51	0.59	0.51	45.3
3	R2	All MCs	133	3.5	133	3.5	0.171	9.1	LOS A	0.8	5.5	0.51	0.59	0.51	44.8
Approach			282	3.5	282	3.5	0.171	6.2	LOS A	0.8	5.5	0.52	0.58	0.52	46.4
East: Tara Road															
4	L2	All MCs	131	3.5	131	3.5	0.264	2.8	LOS A	1.3	9.3	0.38	0.30	0.38	47.3
5	T1	All MCs	523	3.5	523	3.5	0.264	2.2	LOS A	1.3	9.3	0.39	0.29	0.39	50.9
6	R2	All MCs	12	3.5	12	3.5	0.264	8.4	LOS A	1.3	9.1	0.40	0.28	0.40	46.7
Approach			665	3.5	665	3.5	0.264	2.4	LOS A	1.3	9.3	0.39	0.29	0.39	50.1
North: Parton Road															
7	L2	All MCs	11	3.5	11	3.5	0.084	6.1	LOS A	0.4	2.8	0.66	0.61	0.66	46.2
8	T1	All MCs	48	3.5	48	3.5	0.084	5.0	LOS A	0.4	2.8	0.66	0.61	0.66	46.4
9	R2	All MCs	108	3.5	108	3.5	0.115	10.4	LOS B	0.6	4.4	0.66	0.73	0.66	46.0
Approach			167	3.5	167	3.5	0.115	8.6	LOS A	0.6	4.4	0.66	0.68	0.66	46.1
West: Tara Road															
10	L2	All MCs	192	3.5	192	3.5	0.297	4.2	LOS A	1.6	11.3	0.41	0.44	0.41	50.4
11	T1	All MCs	719	3.5	719	3.5	0.488	3.9	LOS A	3.3	23.9	0.45	0.43	0.45	50.0
12	R2	All MCs	102	3.5	102	3.5	0.488	10.4	LOS B	3.3	23.9	0.46	0.42	0.46	49.3
Approach			1013	3.5	1013	3.5	0.488	4.6	LOS A	3.3	23.9	0.44	0.43	0.44	50.0
All Vehicles			2127	3.5	2127	3.5	0.488	4.5	LOS A	3.3	23.9	0.45	0.42	0.45	49.2

Site Level of Service (LOS) Method: Delay (SIDRA). Site LOS Method is specified in the Parameter Settings dialog (Options tab).
 Roundabout LOS Method: SIDRA Roundabout LOS.
 Vehicle movement LOS values are based on average delay per movement.
 Intersection and Approach LOS values are based on average delay for all vehicle movements.
 Roundabout Capacity Model: SIDRA Standard.
 Delay Model: SIDRA Standard (Control Delay: Geometric Delay is included).
 Queue Model: SIDRA queue estimation methods are used for Back of Queue and Queue at Start of Gap.
 Gap-Acceptance Capacity Formula: SIDRA Standard (Akçelik M3D).
 HV (%) values are calculated for All Movement Classes of All Heavy Vehicle Model Designation.
 Arrival Flows used in performance calculations are adjusted to include any Initial Queued Demand and Upstream Capacity Constraint effects.

SIDRA Network and Intersection Outputs

2063 10D Mitigated AM

NETWORK LAYOUT

Network: N101 [2063_Opt10D_AM (Network Folder: General)]

New Network
 Network Category: (None)

Layout pictures are schematic functional drawings reflecting input data. They are not design drawings.

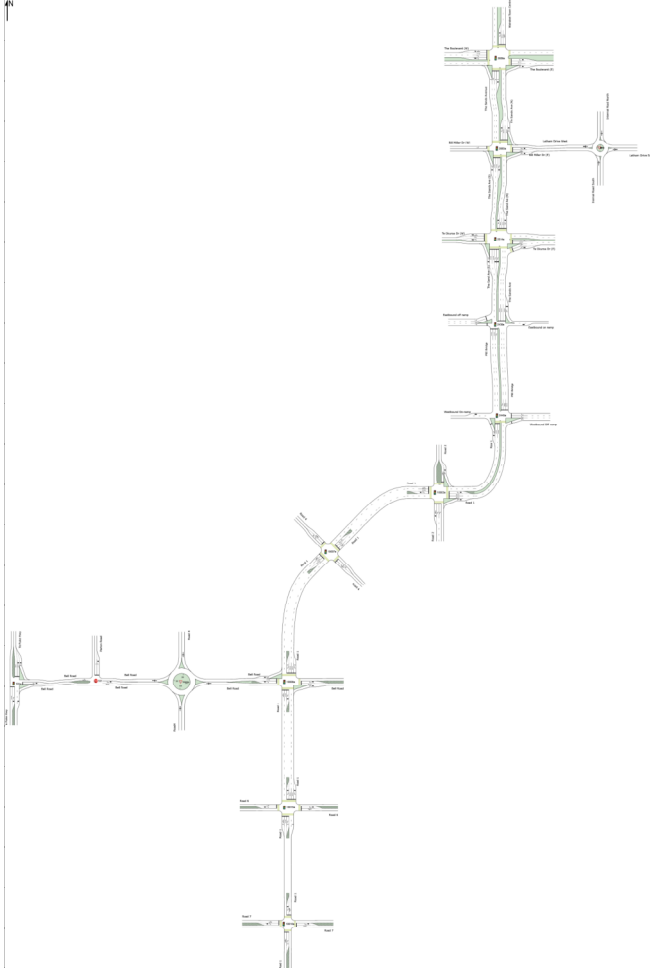

SITES IN NETWORK		
Site ID	CCG ID	Site Name
2859a	NA	2859 Boulv_TheSand_AM
2860a	NA	2860 The Sand_Bill Miller_AM
2514a	NA	2514 Sands_Te Okuroa_AM
2439a	CCG1	2439 Papamoia Eastern Int North_AM
2440a	CCG1	2440 Papamoia Eastern Int South_AM
10003a	NA	10003_AM
10007a	NA	10007_AM
10008a	NA	10008_AM
10015a	NA	10015_AM
10016a	NA	10016_AM
10013a	NA	10013_AM
101	NA	1348 Bell Rd Parton Rd AM
101v	NA	2140 Te Puke Hwy Bell Rd AM Signals
99a	NA	MIBA Internal Roundabout AM

APPROACH LEVEL OF SERVICE

Approach Level of Service

Network: N101 [2063_Opt10D_AM (Network Folder: General)]

Output produced by SIDRA INTERSECTION Version: 9.1.6.228

New Network

Network Category: (None)

Network Cycle Time = 120 seconds (Network Optimum Cycle Time - Minimum Delay)

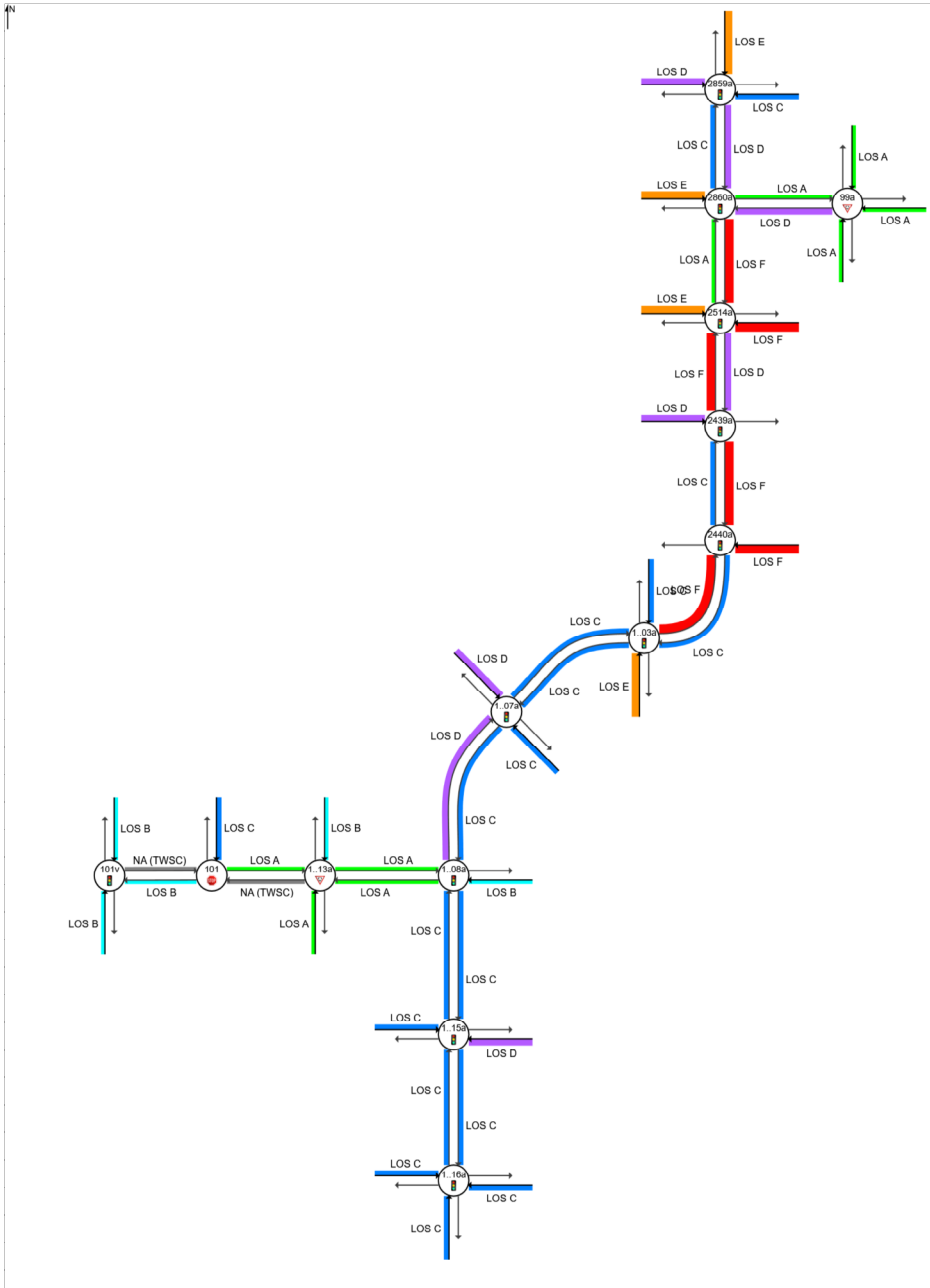

Colour code based on Level of Service

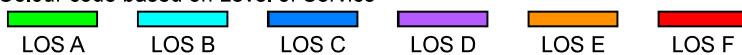

NA (TWSC): Level of Service is not defined for major road approaches or the intersection as a whole for Two-Way Sign Control (HCM LOS rule).

Site Level of Service (LOS) Method: Delay (SIDRA). Site LOS Method is specified in the Network Data dialog (Override Site Data tab).

Delay Model: SIDRA Standard (Control Delay: Geometric Delay is included).

DEGREE OF SATURATION

Ratio of Arrival Flow to Capacity, v/c ratio per lane

Network: N101 [2063_Opt10D_AM (Network Folder: General)]

Output produced by SIDRA INTERSECTION Version: 9.1.6.228

New Network

Network Category: (None)

Network Cycle Time = 120 seconds (Network Optimum Cycle Time - Minimum Delay)

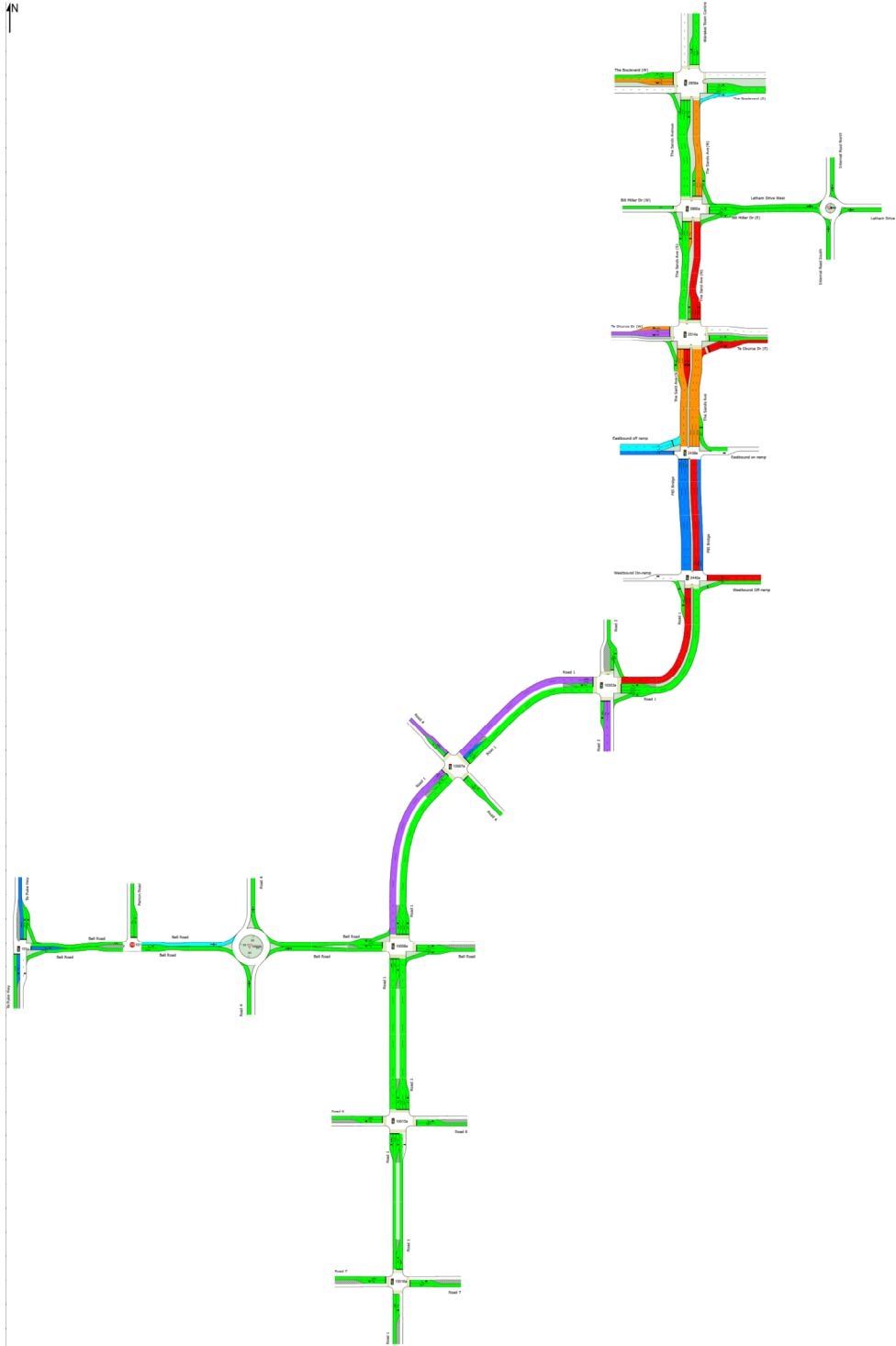

Colour code based on Degree of Saturation

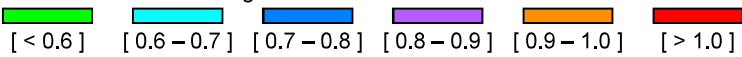

QUEUE STORAGE RATIO (PERCENTILE)

Ratio of the 95% Back of Queue Distance to the available queue storage distance per lane

Network: N101 [2063_Opt10D_AM (Network Folder: General)]

Output produced by SIDRA INTERSECTION Version: 9.1.6.228

New Network

Network Category: (None)

Network Cycle Time = 120 seconds (Network Optimum Cycle Time - Minimum Delay)

Short Lanes are not included in determining Queue Storage Ratios.

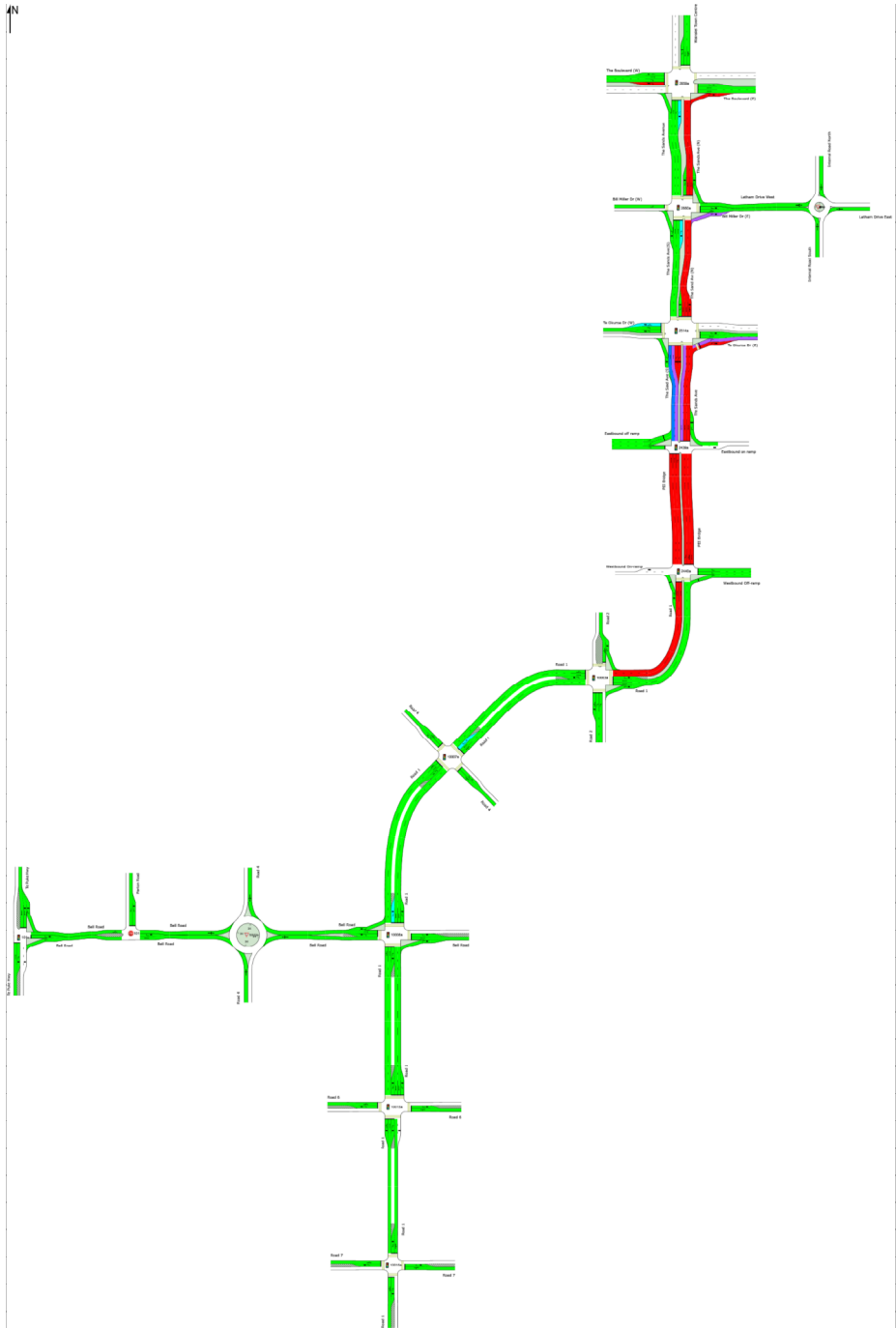

Colour code based on Queue Storage Ratio

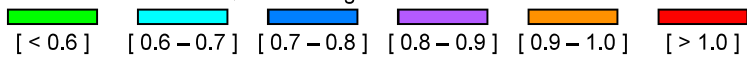

Queue Model: SIDRA queue estimation methods are used for Back of Queue and Queue at Start of Green.

CCG MOVEMENT SUMMARY

Common Control Group: CCG1 [CCG_1]

Output produced by SIDRA INTERSECTION Version: 9.1.6.228

Network: N101
[2063_Opt10D_AM (Network Folder: General)]

EQUISAT (Fixed-Time/SCATS) Coordinated Cycle Time = 120 seconds (Network Optimum Cycle Time - Minimum Delay)

Vehicle Movement Performance (CCG)													
Mov ID	Turn	Mov Class	Demand Flows [Total HV] veh/h %	Arrival Flows [Total HV] veh/h %	Deg. Satn v/c	Aver. Delay sec	Level of Service	Aver. Back Of Queue [Veh. veh]	Prop. Que	Eff. Stop Rate	Aver. No. of Cycles	Aver. Speed km/h	
Site: 2439a [2439 Papamoa Eastern Int North_AM]													
South: PEI Bridge													
2	T1	All MCs	1322 11.4	1162 11.4	0.778	14.9	LOS B	15.0	115.0	0.70	0.64	0.71	19.2
3	R2	All MCs	335 11.4	294 11.4	0.726	66.1	LOS E	10.7	82.4	1.00	0.91	1.02	20.4
Approach			1657 11.4	1456 11.4	0.778	25.2	LOS C	15.0	115.0	0.76	0.70	0.77	19.8
North: The Sands Ave													
7	L2	All MCs	1039 11.4	958 11.4	0.552	4.8	LOS A	0.0	0.0	0.00	0.46	0.00	45.0
8	T1	All MCs	1458 11.4	1344 11.4	0.988	66.5	LOS E	24.9	191.5	0.90	1.21	1.35	11.1
Approach			2497 11.4	2302 11.4	0.988	40.8	LOS D	24.9	191.5	0.53	0.90	0.79	22.7
West: Eastbound off ramp													
10	L2	All MCs	768 11.4	768 11.4	0.631	34.4	LOS C	12.9	99.0	0.85	0.82	0.85	26.2
12	R2	All MCs	86 11.4	86 11.4	0.702	64.0	LOS E	3.3	25.2	1.00	0.88	1.15	18.4
Approach			855 11.4	855 11.4	0.702	37.4	LOS D	12.9	99.0	0.86	0.83	0.88	25.1
All Vehicles			5008 11.4	4612 12.4	0.988	35.2	LOS D	24.9	191.5	0.66	0.82	0.80	22.7
Site: 2440a [2440 Papamoa Eastern Int South_AM]													
South: Road 1													
1	L2	All MCs	232 11.9	232 11.9	0.200	12.5	LOS B	3.1	23.6	0.40	0.64	0.40	40.9
2	T1	All MCs	1063 11.9	1063 11.9	* 1.138	187.9	LOS F	44.5	343.5	1.00	1.88	2.14	6.1
Approach			1295 11.9	1295 11.9	1.138	156.5	LOS F	44.5	343.5	0.89	1.66	1.83	8.6
East: Westbound Off-ramp													
4	L2	All MCs	163 11.9	163 11.9	0.197	23.4	LOS C	3.3	25.4	0.61	0.70	0.61	30.9
6	R2	All MCs	589 11.9	589 11.9	* 1.121	188.3	LOS F	20.8	160.3	1.00	1.46	2.14	8.3
Approach			753 11.9	753 11.9	1.121	152.6	LOS F	20.8	160.3	0.91	1.29	1.80	9.8
North: PEI Bridge													
8	T1	All MCs	612 11.9	567 12.0	0.752	18.4	LOS B	14.0	108.0	0.74	0.67	0.74	16.7
9	R2	All MCs	951 11.9	881 12.0	* 1.144	181.1	LOS F	14.9	115.0	1.00	1.45	2.08	10.0
Approach			1562 11.9	1447 12.0	1.144	117.4	LOS F	14.9	115.0	0.90	1.14	1.56	10.5
All Vehicles			3609 11.9	3495 12.3	1.144	139.5	LOS F	44.5	343.5	0.90	1.37	1.71	9.6

Site Level of Service (LOS) Method: Delay (SIDRA). Site LOS Method is specified in the Network Data dialog (Override Site Data tab).

Vehicle movement LOS values are based on average delay per movement.

Intersection and Approach LOS values are based on average delay for all vehicle movements.

Delay Model: SIDRA Standard (Control Delay: Geometric Delay is included).

Gap-Acceptance Capacity Formula: SIDRA Standard (Akçelik M3D).

HV (%) values are calculated for All Movement Classes of All Heavy Vehicle Model Designation.

Arrival Flows used in performance calculations are adjusted to include any Initial Queued Demand and Upstream Capacity Constraint effects.

* Critical Movement (Signal Timing)

MOVEMENT SUMMARY

Site: 2859a [2859 Boulv_TheSand_AM (Site Folder: General)]

Output produced by SIDRA INTERSECTION Version: 9.1.6.228

Network: N101
[2063_Opt10D_AM (Network Folder: General)]

Site Category: (None)

Signals - EQUISAT (Fixed-Time/SCATS) Coordinated Cycle Time = 120 seconds (Network Optimum Cycle Time - Minimum Delay)

Vehicle Movement Performance															
Mov ID	Turn	Mov Class	Demand Flows		Arrival Flows		Deg. Satn	Aver. Delay	Level of Service	Aver. Back Of Queue		Prop. Que	Eff. Stop Rate	Aver. No. of Cycles	Aver. Speed
			[Total HV]	%	[Total HV]	%	v/c	sec		[Veh. veh	Dist]				km/h
			veh/h		veh/h					veh	m				
South: The Sands Avenue															
1	L2	All MCs	505	6.3	473	6.3	0.312	5.0	LOS A	1.2	8.8	0.13	0.54	0.13	41.6
2	T1	All MCs	60	6.3	56	6.3	*0.212	26.8	LOS C	1.1	8.0	0.55	0.42	0.55	32.2
3	R2	All MCs	288	6.3	270	6.3	0.536	52.9	LOS D	4.4	32.7	0.93	0.78	0.93	19.3
Approach			854	6.3	799	6.3	0.536	22.7	LOS C	4.4	32.7	0.43	0.61	0.43	29.4
East: The Boulevard (E)															
4	L2	All MCs	320	6.3	320	6.3	0.626	23.0	LOS C	7.7	56.8	0.71	0.78	0.71	25.2
5	T1	All MCs	246	6.3	246	6.3	*0.359	46.7	LOS D	3.9	28.9	0.92	0.74	0.92	24.4
6	R2	All MCs	27	6.3	27	6.3	0.103	52.5	LOS D	0.9	6.3	0.90	0.71	0.90	26.2
Approach			594	6.3	594	6.3	0.626	34.2	LOS C	7.7	56.8	0.81	0.76	0.81	24.8
North: Wairakei Town Centre															
7	L2	All MCs	4	6.3	4	6.3	0.440	71.6	LOS E	0.9	6.5	1.00	0.73	1.00	23.0
8	T1	All MCs	39	6.3	39	6.3	0.440	67.2	LOS E	0.9	6.5	1.00	0.73	1.00	18.0
9	R2	All MCs	20	6.3	20	6.3	*0.225	67.4	LOS E	0.7	5.4	0.99	0.70	0.99	23.0
Approach			63	6.3	63	6.3	0.440	67.6	LOS E	0.9	6.5	1.00	0.72	1.00	20.1
West: The Boulevard (W)															
10	L2	All MCs	14	6.3	14	6.3	0.153	24.6	LOS C	2.7	19.8	0.62	0.53	0.62	36.1
11	T1	All MCs	248	6.3	248	6.3	0.153	20.0	LOS C	2.7	19.9	0.62	0.52	0.62	34.3
12	R2	All MCs	668	6.3	668	6.3	*0.903	47.0	LOS D	10.1	74.3	1.00	1.05	1.30	16.3
Approach			931	6.3	931	6.3	0.903	39.4	LOS D	10.1	74.3	0.89	0.90	1.11	21.2
All Vehicles			2441	6.3	2387	6.4	0.903	33.3	LOS C	10.1	74.3	0.72	0.76	0.80	24.5

Site Level of Service (LOS) Method: Delay (SIDRA). Site LOS Method is specified in the Network Data dialog (Override Site Data tab).

Vehicle movement LOS values are based on average delay per movement.

Intersection and Approach LOS values are based on average delay for all vehicle movements.

Delay Model: SIDRA Standard (Control Delay: Geometric Delay is included).

Queue Model: SIDRA queue estimation methods are used for Back of Queue and Queue at Start of Green.

Gap-Acceptance Capacity Formula: SIDRA Standard (Akçelik M3D).

HV (%) values are calculated for All Movement Classes of All Heavy Vehicle Model Designation.

Arrival Flows used in performance calculations are adjusted to include any Initial Queued Demand and Upstream Capacity Constraint effects.

* Critical Movement (Signal Timing)

Pedestrian Movement Performance											
Mov ID	Crossing	Dem. Flow	Aver. Delay	Level of Service	AVERAGE BACK OF QUEUE		Prop. Que	Eff. Stop Rate	Travel Time	Travel Dist.	Aver. Speed
		ped/h	sec		[Ped ped	Dist]			sec	m	m/sec
					ped	m					

South: The Sands Avenue											
P1 Full	32	54.2	LOS E	0.1	0.1	0.95	0.95	69.6	20.0	0.29	
East: The Boulevard (E)											
P21 Stage 1	32	29.5	LOS C	0.1	0.1	0.90	0.90	44.9	20.0	0.45	
P22 Stage 2	32	54.2	LOS E	0.1	0.1	0.95	0.95	69.6	20.0	0.29	
North: Wairakei Town Centre											
P3 Full	32	54.2	LOS E	0.1	0.1	0.95	0.95	69.6	20.0	0.29	
West: The Boulevard (W)											
P4 Full	32	54.2	LOS E	0.1	0.1	0.95	0.95	69.6	20.0	0.29	
All Pedestrians	158	49.3	LOS E	0.1	0.1	0.94	0.94	64.7	20.0	0.31	

Level of Service (LOS) Method: SIDRA Pedestrian LOS Method (Based on Average Delay)

Pedestrian movement LOS values are based on average delay per pedestrian movement.

Intersection LOS value for Pedestrians is based on average delay for all pedestrian movements.

SIDRA INTERSECTION 9.1 | Copyright © 2000-2024 Kcelik and Associates Pty Ltd | sidrasolutions.com

Organisation: AJW | Licence: NETWORK / 1PC | Processed: Friday, 27 March 2026 7:45:56 pm

Project: C:\Users\annaj\OneDrive\AW Consulting\Projects\Boffa Miskell Jobs\Wairakei South\ITA Work Feb 2026\Final SIDRA Modelling\Third Round Base Sidra File\2063_TTHM 10D Mitigated.sip9

MOVEMENT SUMMARY

Site: 2860a [2860 The Sand_Bill Miller_AM (Site Folder: General)]

Output produced by SIDRA INTERSECTION Version: 9.1.6.228

Network: N101
[2063_Opt10D_AM (Network Folder: General)]

Site Category: (None)

Signals - EQUISAT (Fixed-Time/SCATS) Coordinated Cycle Time = 120 seconds (Network Optimum Cycle Time - Minimum Delay)

Vehicle Movement Performance															
Mov ID	Turn	Mov Class	Demand Flows [Total HV] veh/h	%	Arrival Flows [Total HV] veh/h	%	Deg. Satn v/c	Aver. Delay sec	Level of Service	Aver. Back Of Queue [Veh. veh]	Prop. Que	Eff. Stop Rate	Aver. No. of Cycles	Aver. Speed km/h	
South: The Sands Ave (S)															
1	L2	All MCs	7	8.8	7	8.8	0.004	4.6	LOS A	0.0	0.0	0.02	0.49	0.02	44.1
2	T1	All MCs	801	8.8	746	8.8	0.324	0.5	LOS A	0.4	2.9	0.03	0.03	0.03	47.8
3	R2	All MCs	86	8.8	80	8.8	*0.920	78.9	LOS E	3.3	24.8	1.00	0.95	1.35	6.1
Approach			895	8.8	833	8.8	0.920	8.1	LOS A	3.3	24.8	0.12	0.12	0.16	28.8
East: Bill Miller Dr (E)															
4	L2	All MCs	149	8.8	149	8.8	0.504	39.4	LOS D	4.2	32.0	0.85	0.90	0.85	8.0
5	T1	All MCs	2	8.8	2	8.8	*0.058	44.5	LOS D	0.5	4.1	0.86	0.68	0.86	23.6
6	R2	All MCs	34	8.8	34	8.8	0.058	49.1	LOS D	0.5	4.1	0.86	0.68	0.86	6.6
Approach			185	8.8	185	8.8	0.504	41.2	LOS D	4.2	32.0	0.85	0.86	0.85	8.0
North: The Sands Ave (N)															
7	L2	All MCs	135	8.8	135	8.8	0.086	5.0	LOS A	0.3	2.2	0.10	0.52	0.10	35.5
8	T1	All MCs	1049	8.8	1049	8.8	*0.943	45.3	LOS D	19.3	145.0	0.92	1.07	1.19	10.2
9	R2	All MCs	9	8.8	9	8.8	0.108	68.6	LOS E	0.4	2.7	1.00	0.68	1.00	20.2
Approach			1194	8.8	1194	8.8	0.943	40.9	LOS D	19.3	145.0	0.83	1.00	1.07	11.3
West: Bill Miller Dr (W)															
10	L2	All MCs	18	8.8	18	8.8	0.205	67.5	LOS E	0.7	4.9	0.99	0.70	0.99	17.8
Approach			18	8.8	18	8.8	0.205	67.5	LOS E	0.7	4.9	0.99	0.70	0.99	17.8
All Vehicles			2292	8.8	2230	9.0	0.943	28.9	LOS C	19.3	145.0	0.57	0.66	0.71	14.2

Site Level of Service (LOS) Method: Delay (SIDRA). Site LOS Method is specified in the Network Data dialog (Override Site Data tab).

Vehicle movement LOS values are based on average delay per movement.

Intersection and Approach LOS values are based on average delay for all vehicle movements.

Delay Model: SIDRA Standard (Control Delay: Geometric Delay is included).

Queue Model: SIDRA queue estimation methods are used for Back of Queue and Queue at Start of Green.

Gap-Acceptance Capacity Formula: SIDRA Standard (Akçelik M3D).

HV (%) values are calculated for All Movement Classes of All Heavy Vehicle Model Designation.

Arrival Flows used in performance calculations are adjusted to include any Initial Queued Demand and Upstream Capacity Constraint effects.

* Critical Movement (Signal Timing)

Pedestrian Movement Performance											
Mov ID	Crossing	Dem. Flow ped/h	Aver. Delay sec	Level of Service	AVERAGE BACK OF QUEUE [Ped ped Dist] m		Prop. Que	Eff. Stop Rate	Travel Time sec	Travel Dist. m	Aver. Speed m/sec
South: The Sands Ave (S)											
P1	Full	32	54.2	LOS E	0.1	0.1	0.95	0.95	69.6	20.0	0.29

East: Bill Miller Dr (E)											
P2	Full	32	54.2	LOS E	0.1	0.1	0.95	0.95	69.6	20.0	0.29
North: The Sands Ave (N)											
P3	Full	32	54.2	LOS E	0.1	0.1	0.95	0.95	69.6	20.0	0.29
West: Bill Miller Dr (W)											
P4	Full	32	54.2	LOS E	0.1	0.1	0.95	0.95	69.6	20.0	0.29
All Pedestrians		126	54.2	LOS E	0.1	0.1	0.95	0.95	69.6	20.0	0.29

Level of Service (LOS) Method: SIDRA Pedestrian LOS Method (Based on Average Delay)

Pedestrian movement LOS values are based on average delay per pedestrian movement.

Intersection LOS value for Pedestrians is based on average delay for all pedestrian movements.

SIDRA INTERSECTION 9.1 | Copyright © 2000-2024 Akcelik and Associates Pty Ltd | sidrasolutions.com

Organisation: AJW | Licence: NETWORK / 1PC | Processed: Friday, 27 March 2026 7:45:56 pm

Project: C:\Users\annaj\OneDrive\AW Consulting\Projects\Boffa Miskell Jobs\Wairakei South\ITA Work Feb 2026\Final SIDRA Modelling\Third Round Base Sidra File\2063_TTHM 10D Mitigated.sip9

MOVEMENT SUMMARY

Site: 2514a [2514 Sands_Te Okuroa_AM (Site Folder: General)]

Output produced by SIDRA INTERSECTION Version: 9.1.6.228

Network: N101
[2063_Opt10D_AM (Network Folder: General)]

Site Category: (None)

Signals - EQUISAT (Fixed-Time/SCATS) Coordinated Cycle Time = 120 seconds (Network Optimum Cycle Time - Minimum Delay)

Vehicle Movement Performance													
Mov ID	Turn	Mov Class	Demand Flows [Total HV] veh/h %	Arrival Flows [Total HV] veh/h %	Deg. Satn v/c	Aver. Delay sec	Level of Service	Aver. Back Of Queue [Veh. veh]	Prop. Que	Eff. Stop Rate	Aver. No. of Cycles	Aver. Speed km/h	
South: The Sand Ave (S)													
1	L2	All MCs	242 10.9	224 10.9	0.164	13.8	LOS B	0.2	1.3	0.03	0.50	0.03	44.9
2	T1	All MCs	812 10.9	750 10.9	0.972	66.1	LOS E	17.9	136.9	1.00	1.13	1.31	12.1
3	R2	All MCs	1047 10.9	968 10.9	* 1.053	130.5	LOS F	26.9	206.0	1.00	1.32	1.68	14.9
Approach			2101 10.9	1941 10.9	1.053	92.2	LOS F	26.9	206.0	0.89	1.16	1.35	15.5
East: Te Okuroa Dr (E)													
4	L2	All MCs	1073 10.9	1073 10.9	1.048	124.2	LOS F	32.9	252.0	1.00	1.38	1.72	11.6
5	T1	All MCs	76 10.9	76 10.9	* 0.263	48.5	LOS D	2.4	18.6	0.92	0.72	0.92	30.2
6	R2	All MCs	35 10.9	35 10.9	0.127	51.8	LOS D	1.1	8.3	0.89	0.72	0.89	21.1
Approach			1183 10.9	1183 10.9	1.048	117.2	LOS F	32.9	252.0	0.99	1.31	1.65	12.7
North: The Sand Ave (N)													
7	L2	All MCs	107 10.9	107 10.9	1.160	233.4	LOS F	17.2	132.0	1.00	1.75	2.19	8.9
8	T1	All MCs	1053 10.9	1053 10.9	* 1.160	225.8	LOS F	17.2	132.0	1.00	1.81	2.17	2.5
9	R2	All MCs	49 10.9	49 10.9	0.108	52.0	LOS D	1.3	10.2	0.79	0.71	0.79	26.4
Approach			1209 10.9	1209 10.9	1.160	219.4	LOS F	17.2	132.0	0.99	1.76	2.11	3.4
West: Te Okuroa Dr (W)													
10	L2	All MCs	46 10.9	46 10.9	0.939	41.4	LOS D	10.4	79.4	1.00	1.16	1.43	16.5
11	T1	All MCs	195 10.9	195 10.9	* 0.939	85.9	LOS F	10.4	79.4	1.00	1.16	1.43	24.5
12	R2	All MCs	373 10.9	373 10.9	0.825	66.1	LOS E	7.7	59.2	1.00	0.96	1.21	18.2
Approach			614 10.9	614 10.9	0.939	70.5	LOS E	10.4	79.4	1.00	1.04	1.30	20.6
All Vehicles			5107 10.9	4948 11.3	1.160	126.6	LOS F	32.9	252.0	0.95	1.33	1.60	11.1

Site Level of Service (LOS) Method: Delay (SIDRA). Site LOS Method is specified in the Network Data dialog (Override Site Data tab).

Vehicle movement LOS values are based on average delay per movement.

Intersection and Approach LOS values are based on average delay for all vehicle movements.

Delay Model: SIDRA Standard (Control Delay: Geometric Delay is included).

Queue Model: SIDRA queue estimation methods are used for Back of Queue and Queue at Start of Green.

Gap-Acceptance Capacity Formula: SIDRA Standard (Akçelik M3D).

HV (%) values are calculated for All Movement Classes of All Heavy Vehicle Model Designation.

Arrival Flows used in performance calculations are adjusted to include any Initial Queued Demand and Upstream Capacity Constraint effects.

* Critical Movement (Signal Timing)

Pedestrian Movement Performance										
Mov ID	Crossing	Dem. Flow ped/h	Aver. Delay sec	Level of Service	AVERAGE BACK OF QUEUE [Ped ped]	Prop. Que	Eff. Stop Rate	Travel Time sec	Travel Dist. m	Aver. Speed m/sec
					[Dist] m					

South: The Sand Ave (S)											
P1	Full	32	54.2	LOS E	0.1	0.1	0.95	0.95	69.6	20.0	0.29
East: Te Okuroa Dr (E)											
P2	Full	32	54.2	LOS E	0.1	0.1	0.95	0.95	69.6	20.0	0.29
P2B	Slip/ Bypass	32	54.2	LOS E	0.1	0.1	0.95	0.95	69.6	20.0	0.29
North: The Sand Ave (N)											
P3	Full	32	54.2	LOS E	0.1	0.1	0.95	0.95	69.6	20.0	0.29
West: Te Okuroa Dr (W)											
P4	Full	32	54.2	LOS E	0.1	0.1	0.95	0.95	69.6	20.0	0.29
All Pedestrians		158	54.2	LOS E	0.1	0.1	0.95	0.95	69.6	20.0	0.29

Level of Service (LOS) Method: SIDRA Pedestrian LOS Method (Based on Average Delay)

Pedestrian movement LOS values are based on average delay per pedestrian movement.

Intersection LOS value for Pedestrians is based on average delay for all pedestrian movements.

SIDRA INTERSECTION 9.1 | Copyright © 2000-2024 Akcelik and Associates Pty Ltd | sidrasolutions.com

Organisation: AJW | Licence: NETWORK / 1PC | Processed: Friday, 27 March 2026 7:45:56 pm

Project: C:\Users\annaj\OneDrive\AW Consulting\Projects\Boffa Miskell Jobs\Wairakei South\ITA Work Feb 2026\Final SIDRA Modelling\Third Round Base Sidra File\2063_TTHM 10D Mitigated.sip9

MOVEMENT SUMMARY

Site: 10003a [10003_AM (Site Folder: General)]

Output produced by SIDRA INTERSECTION Version: 9.1.6.228

Network: N101
[2063_Opt10D_AM (Network Folder: General)]

NA

Site Category: (None)

Signals - EQUISAT (Fixed-Time/SCATS) Isolated Cycle Time = 110 seconds (Site Practical Cycle Time)

Vehicle Movement Performance															
Mov ID	Turn	Mov Class	Demand Flows		Arrival Flows		Deg. Satn	Aver. Delay	Level of Service	Aver. Back Of Queue		Prop. Que	Eff. Stop Rate	Aver. No. of Cycles	Aver. Speed
			[Total HV]	[Total HV]			v/c	sec			[Veh. veh]	[Dist] m			
			veh/h	%	veh/h	%									
South: Road 2															
1	L2	All MCs	4	9.9	4	9.9	0.035	41.2	LOS D	0.3	2.0	0.88	0.63	0.88	10.7
2	T1	All MCs	5	9.9	5	9.9	0.035	47.8	LOS D	0.3	2.0	0.88	0.63	0.88	25.9
3	R2	All MCs	259	9.9	259	9.9	*0.814	63.4	LOS E	5.8	43.8	1.00	0.97	1.28	8.1
Approach			268	9.9	268	9.9	0.814	62.8	LOS E	5.8	43.8	1.00	0.96	1.26	8.5
East: Road 1															
4	L2	All MCs	55	9.9	52	9.9	0.034	4.9	LOS A	0.1	0.7	0.12	0.52	0.12	41.8
5	T1	All MCs	454	9.9	427	9.9	0.252	19.0	LOS B	4.2	32.0	0.65	0.55	0.65	29.2
6	R2	All MCs	48	9.9	46	9.9	*0.482	63.3	LOS E	1.6	12.0	1.00	0.74	1.00	24.6
Approach			557	9.9	524	9.9	0.482	21.5	LOS C	4.2	32.0	0.62	0.56	0.62	29.3
North: Road 2															
7	L2	All MCs	106	9.9	106	9.9	0.193	20.8	LOS C	1.9	14.7	0.63	0.70	0.63	32.2
8	T1	All MCs	4	9.9	4	9.9	*0.128	46.9	LOS D	0.8	6.4	0.92	0.71	0.92	24.4
9	R2	All MCs	24	9.9	24	9.9	0.128	51.5	LOS D	0.8	6.4	0.92	0.71	0.92	21.3
Approach			135	9.9	135	9.9	0.193	27.1	LOS C	1.9	14.7	0.69	0.70	0.69	29.2
West: Road 1															
10	L2	All MCs	20	9.9	20	9.9	0.826	21.6	LOS C	18.2	138.4	0.93	0.90	1.01	33.3
11	T1	All MCs	925	9.9	925	9.9	*0.826	34.5	LOS C	18.2	138.4	0.93	0.93	1.04	24.3
12	R2	All MCs	13	9.9	13	9.9	0.133	61.3	LOS E	0.4	3.2	0.98	0.68	0.98	20.2
Approach			958	9.9	958	9.9	0.826	34.6	LOS C	18.2	138.4	0.93	0.92	1.04	24.5
All Vehicles			1918	9.9	1886	10.1	0.826	34.4	LOS C	18.2	138.4	0.84	0.81	0.93	23.3

Site Level of Service (LOS) Method: Delay (SIDRA). Site LOS Method is specified in the Network Data dialog (Override Site Data tab).

Vehicle movement LOS values are based on average delay per movement.

Intersection and Approach LOS values are based on average delay for all vehicle movements.

Delay Model: SIDRA Standard (Control Delay; Geometric Delay is included).

Queue Model: SIDRA queue estimation methods are used for Back of Queue and Queue at Start of Green.

Gap-Acceptance Capacity Formula: SIDRA Standard (Akçelik M3D).

HV (%) values are calculated for All Movement Classes of All Heavy Vehicle Model Designation.

Arrival Flows used in performance calculations are adjusted to include any Initial Queued Demand and Upstream Capacity Constraint effects.

* Critical Movement (Signal Timing)

Pedestrian Movement Performance												
Mov ID	Crossing	Dem. Flow	Aver. Delay	Level of Service	AVERAGE BACK OF QUEUE		Prop. Que	Eff. Stop Rate	Travel Time	Travel Dist.	Aver. Speed	
		ped/h	sec			[Ped ped]	[Dist] m			sec	m	m/sec
South: Road 2												
P1	Full	32	49.2	LOS E	0.1	0.1	0.95	0.95	203.1	200.0	0.98	

East: Road 1											
P2	Full	32	49.2	LOS E	0.1	0.1	0.95	0.95	203.1	200.0	0.98
North: Road 2											
P3	Full	32	49.2	LOS E	0.1	0.1	0.95	0.95	203.1	200.0	0.98
West: Road 1											
P4	Full	32	49.2	LOS E	0.1	0.1	0.95	0.95	203.1	200.0	0.98
All Pedestrians		126	49.2	LOS E	0.1	0.1	0.95	0.95	203.1	200.0	0.98

Level of Service (LOS) Method: SIDRA Pedestrian LOS Method (Based on Average Delay)

Pedestrian movement LOS values are based on average delay per pedestrian movement.

Intersection LOS value for Pedestrians is based on average delay for all pedestrian movements.

SIDRA INTERSECTION 9.1 | Copyright © 2000-2024 Akcelik and Associates Pty Ltd | sidrasolutions.com

Organisation: AJW | Licence: NETWORK / 1PC | Processed: Friday, 27 March 2026 7:45:56 pm

Project: C:\Users\annaj\OneDrive\AW Consulting\Projects\Boffa Miskell Jobs\Wairakei South\ITA Work Feb 2026\Final SIDRA Modelling\Third Round Base Sidra File\2063_TTHM 10D Mitigated.sip9

MOVEMENT SUMMARY

Site: 10007a [10007_AM (Site Folder: General)]

Output produced by SIDRA INTERSECTION Version: 9.1.6.228

Network: N101
[2063_Opt10D_AM (Network Folder: General)]

NA

Site Category: (None)

Signals - EQUISAT (Fixed-Time/SCATS) Isolated Cycle Time = 70 seconds (Site Practical Cycle Time)

Vehicle Movement Performance															
Mov ID	Turn	Mov Class	Demand Flows		Arrival Flows		Deg. Satn	Aver. Delay	Level of Service	Aver. Back Of Queue		Prop. Que	Eff. Stop Rate	Aver. No. of Cycles	Aver. Speed
			[Total HV]	[Total HV]	[Total HV]	[Total HV]	v/c	sec		[Veh. veh	Dist]				km/h
			veh/h	%	veh/h	%				veh	m				
SouthEast: Road 4															
21	L2	All MCs	41	10.8	41	10.8	0.094	23.1	LOS C	0.8	5.9	0.74	0.67	0.74	31.4
22	T1	All MCs	11	10.8	11	10.8	0.094	18.4	LOS B	0.8	5.9	0.74	0.67	0.74	38.2
23	R2	All MCs	2	10.8	2	10.8	0.014	37.5	LOS D	0.0	0.3	0.93	0.61	0.93	24.9
Approach			54	10.8	54	10.8	0.094	22.7	LOS C	0.8	5.9	0.75	0.67	0.75	33.0
NorthEast: Road 1															
24	L2	All MCs	4	10.8	4	10.9	0.561	35.6	LOS D	3.3	25.0	0.97	0.78	0.97	33.6
25	T1	All MCs	335	10.8	317	10.9	0.561	30.9	LOS C	3.3	25.0	0.97	0.78	0.97	25.4
26	R2	All MCs	144	10.8	136	10.9	*0.791	43.6	LOS D	3.2	24.5	1.00	0.96	1.32	29.7
Approach			483	10.8	457	10.9	0.791	34.7	LOS C	3.3	25.0	0.98	0.84	1.08	27.3
NorthWest: Road 4															
27	L2	All MCs	465	10.8	465	10.8	0.872	41.3	LOS D	11.5	88.3	1.00	1.02	1.30	23.9
28	T1	All MCs	7	10.8	7	10.8	*0.872	36.7	LOS D	11.5	88.3	1.00	1.02	1.30	32.4
29	R2	All MCs	5	10.8	5	10.8	*0.036	40.1	LOS D	0.1	0.8	0.94	0.64	0.94	24.3
Approach			478	10.8	478	10.8	0.872	41.3	LOS D	11.5	88.3	1.00	1.02	1.29	23.4
SouthWest: Road 1															
30	L2	All MCs	15	10.8	15	10.8	0.873	45.1	LOS D	6.2	47.1	1.00	1.09	1.42	26.9
31	T1	All MCs	484	10.8	484	10.8	*0.873	40.4	LOS D	6.2	47.2	1.00	1.09	1.42	13.7
32	R2	All MCs	29	10.8	29	10.8	0.171	37.7	LOS D	0.6	4.6	0.95	0.71	0.95	28.2
Approach			528	10.8	528	10.8	0.873	40.4	LOS D	6.2	47.2	1.00	1.07	1.39	15.6
All Vehicles			1543	10.8	1517	11.0	0.873	38.3	LOS D	11.5	88.3	0.98	0.97	1.24	22.8

Site Level of Service (LOS) Method: Delay (SIDRA). Site LOS Method is specified in the Network Data dialog (Override Site Data tab).

Vehicle movement LOS values are based on average delay per movement.

Intersection and Approach LOS values are based on average delay for all vehicle movements.

Delay Model: SIDRA Standard (Control Delay; Geometric Delay is included).

Queue Model: SIDRA queue estimation methods are used for Back of Queue and Queue at Start of Green.

Gap-Acceptance Capacity Formula: SIDRA Standard (Akçelik M3D).

HV (%) values are calculated for All Movement Classes of All Heavy Vehicle Model Designation.

Arrival Flows used in performance calculations are adjusted to include any Initial Queued Demand and Upstream Capacity Constraint effects.

* Critical Movement (Signal Timing)

Pedestrian Movement Performance											
Mov ID	Crossing	Dem. Flow	Aver. Delay	Level of Service	AVERAGE BACK OF QUEUE		Prop. Que	Eff. Stop Rate	Travel Time	Travel Dist.	Aver. Speed
		ped/h	sec		[Ped ped	Dist]			sec	m	m/sec
					ped	m					
SouthEast: Road 4											
P5	Full	32	29.3	LOS C	0.1	0.1	0.92	0.92	183.1	200.0	1.09

NorthEast: Road 1											
P6	Full	32	29.3	LOS C	0.1	0.1	0.92	0.92	183.1	200.0	1.09
NorthWest: Road 4											
P7	Full	32	29.3	LOS C	0.1	0.1	0.92	0.92	183.1	200.0	1.09
SouthWest: Road 1											
P8	Full	32	29.3	LOS C	0.1	0.1	0.92	0.92	183.1	200.0	1.09
All Pedestrians		126	29.3	LOS C	0.1	0.1	0.92	0.92	183.1	200.0	1.09

Level of Service (LOS) Method: SIDRA Pedestrian LOS Method (Based on Average Delay)

Pedestrian movement LOS values are based on average delay per pedestrian movement.

Intersection LOS value for Pedestrians is based on average delay for all pedestrian movements.

SIDRA INTERSECTION 9.1 | Copyright © 2000-2024 Akcelik and Associates Pty Ltd | sidrasolutions.com

Organisation: AJW | Licence: NETWORK / 1PC | Processed: Friday, 27 March 2026 7:45:56 pm

Project: C:\Users\annaj\OneDrive\AW Consulting\Projects\Boffa Miskell Jobs\Wairakei South\ITA Work Feb 2026\Final SIDRA Modelling\Third Round Base Sidra File\2063_TTHM 10D Mitigated.sip9

MOVEMENT SUMMARY

Site: 10008a [10008_AM (Site Folder: General)]

Output produced by SIDRA INTERSECTION Version: 9.1.6.228

Network: N101
[2063_Opt10D_AM (Network Folder: General)]

New Site

Site Category: (None)

Signals - EQUISAT (Fixed-Time/SCATS) Isolated Cycle Time = 70 seconds (Site Practical Cycle Time)

Vehicle Movement Performance															
Mov ID	Turn	Mov Class	Demand Flows		Arrival Flows		Deg. Satn	Aver. Delay	Level of Service	Aver. Back Of Queue		Prop. Que	Eff. Stop Rate	Aver. No. of Cycles	Aver. Speed
			[Total HV]	[Total HV]	[Total HV]	[Total HV]	v/c	sec		[Veh. veh	Dist]				km/h
			veh/h	%	veh/h	%					m				
South: Road 1															
1	L2	All MCs	3	16.8	3	16.8	0.329	23.2	LOS C	1.8	14.1	0.92	0.72	0.92	26.6
2	T1	All MCs	179	16.8	179	16.8	0.329	29.4	LOS C	1.8	14.2	0.92	0.72	0.92	26.5
3	R2	All MCs	12	16.8	12	16.8	0.041	31.4	LOS C	0.2	1.7	0.86	0.67	0.86	34.3
Approach			194	16.8	194	16.8	0.329	29.4	LOS C	1.8	14.2	0.92	0.72	0.92	27.2
East: Bell Road															
4	L2	All MCs	47	16.8	47	16.8	0.037	5.7	LOS A	0.1	1.2	0.25	0.55	0.25	43.9
5	T1	All MCs	78	16.8	78	16.8	*0.182	23.1	LOS C	1.3	10.6	0.83	0.65	0.83	32.0
6	R2	All MCs	12	16.8	12	16.8	*0.081	38.5	LOS D	0.2	1.9	0.95	0.67	0.95	25.9
Approach			137	16.8	137	16.8	0.182	18.4	LOS B	1.3	10.6	0.64	0.62	0.64	34.6
North: Road 1															
7	L2	All MCs	1	16.8	1	17.1	0.002	21.4	LOS C	0.0	0.1	0.69	0.58	0.69	35.0
8	T1	All MCs	232	16.8	221	17.1	*0.401	30.0	LOS C	2.2	17.6	0.94	0.74	0.94	17.1
9	R2	All MCs	152	16.8	145	17.1	*0.510	34.5	LOS C	2.9	23.3	0.95	0.79	0.95	15.7
Approach			384	16.8	367	17.1	0.510	31.8	LOS C	2.9	23.3	0.95	0.76	0.95	16.6
West: Bell Road															
10	L2	All MCs	337	16.8	337	16.8	0.264	5.8	LOS A	1.2	9.6	0.29	0.59	0.29	42.5
11	T1	All MCs	20	16.8	20	16.8	0.047	22.1	LOS C	0.3	2.6	0.79	0.57	0.79	38.4
12	R2	All MCs	4	16.8	4	16.8	0.030	37.9	LOS D	0.1	0.7	0.94	0.63	0.94	23.3
Approach			361	16.8	361	16.8	0.264	7.1	LOS A	1.2	9.6	0.32	0.59	0.32	41.7
All Vehicles			1076	16.8	1059	17.1	0.510	21.2	LOS C	2.9	23.3	0.69	0.68	0.69	29.0

Site Level of Service (LOS) Method: Delay (SIDRA). Site LOS Method is specified in the Network Data dialog (Override Site Data tab).

Vehicle movement LOS values are based on average delay per movement.

Intersection and Approach LOS values are based on average delay for all vehicle movements.

Delay Model: SIDRA Standard (Control Delay; Geometric Delay is included).

Queue Model: SIDRA queue estimation methods are used for Back of Queue and Queue at Start of Green.

Gap-Acceptance Capacity Formula: SIDRA Standard (Akçelik M3D).

HV (%) values are calculated for All Movement Classes of All Heavy Vehicle Model Designation.

Arrival Flows used in performance calculations are adjusted to include any Initial Queued Demand and Upstream Capacity Constraint effects.

* Critical Movement (Signal Timing)

Pedestrian Movement Performance											
Mov ID	Crossing	Dem. Flow	Aver. Delay	Level of Service	AVERAGE BACK OF QUEUE		Prop. Que	Eff. Stop Rate	Travel Time	Travel Dist.	Aver. Speed
		ped/h	sec		[Ped ped	Dist]			sec	m	m/sec
						m					
South: Road 1											
P1	Full	32	29.3	LOS C	0.1	0.1	0.92	0.92	183.1	200.0	1.09

East: Bell Road											
P2	Full	32	29.3	LOS C	0.1	0.1	0.92	0.92	183.1	200.0	1.09
North: Road 1											
P3	Full	32	29.3	LOS C	0.1	0.1	0.92	0.92	183.1	200.0	1.09
West: Bell Road											
P4	Full	32	29.3	LOS C	0.1	0.1	0.92	0.92	183.1	200.0	1.09
All Pedestrians		126	29.3	LOS C	0.1	0.1	0.92	0.92	183.1	200.0	1.09

Level of Service (LOS) Method: SIDRA Pedestrian LOS Method (Based on Average Delay)

Pedestrian movement LOS values are based on average delay per pedestrian movement.

Intersection LOS value for Pedestrians is based on average delay for all pedestrian movements.

SIDRA INTERSECTION 9.1 | Copyright © 2000-2024 Akcelik and Associates Pty Ltd | sidrasolutions.com

Organisation: AJW | Licence: NETWORK / 1PC | Processed: Friday, 27 March 2026 7:45:56 pm

Project: C:\Users\annaj\OneDrive\AW Consulting\Projects\Boffa Miskell Jobs\Wairakei South\ITA Work Feb 2026\Final SIDRA Modelling\Third Round Base Sidra File\2063_TTHM 10D Mitigated.sip9

MOVEMENT SUMMARY

Site: 10015a [10015_AM (Site Folder: General)]

Output produced by SIDRA INTERSECTION Version: 9.1.6.228

Network: N101
[2063_Opt10D_AM (Network Folder: General)]

New Site

Site Category: (None)

Signals - EQUISAT (Fixed-Time/SCATS) Isolated Cycle Time = 70 seconds (Site Practical Cycle Time)

Vehicle Movement Performance															
Mov ID	Turn	Mov Class	Demand Flows		Arrival Flows		Deg. Satn	Aver. Delay	Level of Service	Aver. Back Of Queue		Prop. Que	Eff. Stop Rate	Aver. No. of Cycles	Aver. Speed
			[Total HV]	[Total HV]	[Total HV]	[Total HV]	v/c	sec		[Veh. veh	Dist]				km/h
			veh/h	%	veh/h	%					m				
South: Road 1															
1	L2	All MCs	3	19.9	3	19.9	0.125	22.8	LOS C	0.6	5.2	0.88	0.66	0.88	35.0
2	T1	All MCs	65	19.9	65	19.9	0.125	28.4	LOS C	0.6	5.2	0.89	0.66	0.89	26.9
3	R2	All MCs	2	19.9	2	19.9	0.008	30.9	LOS C	0.0	0.3	0.85	0.61	0.85	33.8
Approach			71	19.9	71	19.9	0.125	28.2	LOS C	0.6	5.2	0.88	0.65	0.88	27.8
East: Road 6															
4	L2	All MCs	1	19.9	1	19.9	0.020	14.6	LOS B	0.1	1.1	0.77	0.54	0.77	31.8
5	T1	All MCs	7	19.9	7	19.9	0.020	22.6	LOS C	0.1	1.1	0.77	0.54	0.77	38.9
6	R2	All MCs	27	19.9	27	19.9	*0.196	39.3	LOS D	0.6	4.7	0.96	0.71	0.96	24.5
Approach			36	19.9	36	19.9	0.196	35.1	LOS D	0.6	4.7	0.92	0.67	0.92	28.2
North: Road 1															
7	L2	All MCs	45	19.9	44	20.2	0.082	22.4	LOS C	0.6	5.2	0.72	0.69	0.72	36.9
8	T1	All MCs	97	19.9	93	20.2	*0.224	28.8	LOS C	1.2	9.5	0.90	0.68	0.90	26.6
9	R2	All MCs	73	19.9	70	20.2	*0.252	33.0	LOS C	1.3	10.9	0.90	0.75	0.90	33.4
Approach			215	19.9	207	20.2	0.252	28.8	LOS C	1.3	10.9	0.87	0.71	0.87	32.0
West: Road 6															
10	L2	All MCs	46	19.9	46	19.9	0.160	17.8	LOS B	1.2	9.9	0.77	0.68	0.77	31.9
11	T1	All MCs	31	19.9	31	19.9	*0.160	29.9	LOS C	1.2	9.9	0.77	0.68	0.77	38.5
12	R2	All MCs	3	19.9	3	19.9	0.023	37.9	LOS D	0.1	0.5	0.94	0.62	0.94	25.5
Approach			80	19.9	80	19.9	0.160	23.2	LOS C	1.2	9.9	0.78	0.68	0.78	34.9
All Vehicles			401	19.9	393	20.3	0.252	28.2	LOS C	1.3	10.9	0.86	0.69	0.86	31.6

Site Level of Service (LOS) Method: Delay (SIDRA). Site LOS Method is specified in the Network Data dialog (Override Site Data tab).

Vehicle movement LOS values are based on average delay per movement.

Intersection and Approach LOS values are based on average delay for all vehicle movements.

Delay Model: SIDRA Standard (Control Delay; Geometric Delay is included).

Queue Model: SIDRA queue estimation methods are used for Back of Queue and Queue at Start of Green.

Gap-Acceptance Capacity Formula: SIDRA Standard (Akçelik M3D).

HV (%) values are calculated for All Movement Classes of All Heavy Vehicle Model Designation.

Arrival Flows used in performance calculations are adjusted to include any Initial Queued Demand and Upstream Capacity Constraint effects.

* Critical Movement (Signal Timing)

Pedestrian Movement Performance											
Mov ID	Crossing	Dem. Flow	Aver. Delay	Level of Service	AVERAGE BACK OF QUEUE		Prop. Que	Eff. Stop Rate	Travel Time	Travel Dist.	Aver. Speed
		ped/h	sec		[Ped ped	Dist]			sec	m	m/sec
						m					
South: Road 1											
P1	Full	32	29.3	LOS C	0.1	0.1	0.92	0.92	183.1	200.0	1.09

East: Road 6											
P2	Full	32	29.3	LOS C	0.1	0.1	0.92	0.92	183.1	200.0	1.09
North: Road 1											
P3	Full	32	29.3	LOS C	0.1	0.1	0.92	0.92	183.1	200.0	1.09
West: Road 6											
P4	Full	32	29.3	LOS C	0.1	0.1	0.92	0.92	183.1	200.0	1.09
All Pedestrians		126	29.3	LOS C	0.1	0.1	0.92	0.92	183.1	200.0	1.09

Level of Service (LOS) Method: SIDRA Pedestrian LOS Method (Based on Average Delay)

Pedestrian movement LOS values are based on average delay per pedestrian movement.

Intersection LOS value for Pedestrians is based on average delay for all pedestrian movements.

SIDRA INTERSECTION 9.1 | Copyright © 2000-2024 Akcelik and Associates Pty Ltd | sidrasolutions.com

Organisation: AJW | Licence: NETWORK / 1PC | Processed: Friday, 27 March 2026 7:45:56 pm

Project: C:\Users\annaj\OneDrive\AW Consulting\Projects\Boffa Miskell Jobs\Wairakei South\ITA Work Feb 2026\Final SIDRA Modelling\Third Round Base Sidra File\2063_TTHM 10D Mitigated.sip9

MOVEMENT SUMMARY

Site: 10016a [10016_AM (Site Folder: General)]

Output produced by SIDRA INTERSECTION Version: 9.1.6.228

Network: N101
[2063_Opt10D_AM (Network Folder: General)]

New Site

Site Category: (None)

Signals - EQUISAT (Fixed-Time/SCATS) Isolated Cycle Time = 60 seconds (Site Practical Cycle Time)

Vehicle Movement Performance															
Mov ID	Turn	Mov Class	Demand Flows		Arrival Flows		Deg. Satn	Aver. Delay	Level of Service	Aver. Back Of Queue		Prop. Que	Eff. Stop Rate	Aver. No. of Cycles	Aver. Speed
			[Total HV]	[Total HV]	[Total HV]	[Total HV]	v/c	sec		[Veh. veh	Dist]				km/h
			veh/h	%	veh/h	%					m				
South: Road 1															
1	L2	All MCs	1	19.1	1	19.1	0.009	18.1	LOS B	0.0	0.4	0.80	0.55	0.80	38.5
2	T1	All MCs	2	19.1	2	19.1	0.009	23.5	LOS C	0.0	0.4	0.80	0.55	0.80	31.6
3	R2	All MCs	1	19.1	1	19.1	0.005	29.6	LOS C	0.0	0.1	0.88	0.59	0.88	34.8
Approach			4	19.1	4	19.1	0.009	23.7	LOS C	0.0	0.4	0.82	0.56	0.82	34.8
East: Road 7															
4	L2	All MCs	1	19.1	1	19.1	0.016	16.7	LOS B	0.1	0.6	0.82	0.56	0.82	37.5
5	T1	All MCs	4	19.1	4	19.1	0.016	23.4	LOS C	0.1	0.6	0.82	0.56	0.82	39.2
6	R2	All MCs	18	19.1	18	19.1	*0.109	33.1	LOS C	0.3	2.6	0.94	0.69	0.94	26.4
Approach			23	19.1	23	19.1	0.109	30.6	LOS C	0.3	2.6	0.91	0.66	0.91	30.2
North: Road 1															
7	L2	All MCs	28	19.1	27	19.4	0.048	17.7	LOS B	0.3	2.7	0.67	0.66	0.67	38.7
8	T1	All MCs	1	19.1	1	19.4	*0.048	22.7	LOS C	0.3	2.7	0.67	0.66	0.67	39.8
9	R2	All MCs	74	19.1	71	19.4	*0.327	31.9	LOS C	1.2	10.1	0.94	0.75	0.94	34.4
Approach			103	19.1	100	19.4	0.327	27.9	LOS C	1.2	10.1	0.87	0.73	0.87	35.5
West: Road 7															
10	L2	All MCs	51	19.1	51	19.1	0.157	18.9	LOS B	1.0	7.8	0.78	0.69	0.78	33.8
11	T1	All MCs	19	19.1	19	19.1	*0.157	27.7	LOS C	1.0	7.8	0.78	0.69	0.78	39.6
12	R2	All MCs	2	19.1	2	19.1	0.013	32.1	LOS C	0.0	0.3	0.92	0.61	0.92	35.0
Approach			72	19.1	72	19.1	0.157	21.6	LOS C	1.0	7.8	0.79	0.69	0.79	35.9
All Vehicles			202	19.1	199	19.4	0.327	25.9	LOS C	1.2	10.1	0.84	0.70	0.84	35.1

Site Level of Service (LOS) Method: Delay (SIDRA). Site LOS Method is specified in the Network Data dialog (Override Site Data tab).

Vehicle movement LOS values are based on average delay per movement.

Intersection and Approach LOS values are based on average delay for all vehicle movements.

Delay Model: SIDRA Standard (Control Delay; Geometric Delay is included).

Queue Model: SIDRA queue estimation methods are used for Back of Queue and Queue at Start of Green.

Gap-Acceptance Capacity Formula: SIDRA Standard (Akçelik M3D).

HV (%) values are calculated for All Movement Classes of All Heavy Vehicle Model Designation.

Arrival Flows used in performance calculations are adjusted to include any Initial Queued Demand and Upstream Capacity Constraint effects.

* Critical Movement (Signal Timing)

Pedestrian Movement Performance											
Mov ID	Crossing	Dem. Flow	Aver. Delay	Level of Service	AVERAGE BACK OF QUEUE		Prop. Que	Eff. Stop Rate	Travel Time	Travel Dist.	Aver. Speed
		ped/h	sec		[Ped ped	Dist]			sec	m	m/sec
						m					
South: Road 1											
P1	Full	32	24.3	LOS C	0.0	0.0	0.90	0.90	178.2	200.0	1.12

East: Road 7											
P2 Full	32	24.3	LOS C	0.0	0.0	0.90	0.90	178.2	200.0	1.12	
North: Road 1											
P3 Full	32	24.3	LOS C	0.0	0.0	0.90	0.90	178.2	200.0	1.12	
West: Road 7											
P4 Full	32	24.3	LOS C	0.0	0.0	0.90	0.90	178.2	200.0	1.12	
All Pedestrians	126	24.3	LOS C	0.0	0.0	0.90	0.90	178.2	200.0	1.12	

Level of Service (LOS) Method: SIDRA Pedestrian LOS Method (Based on Average Delay)

Pedestrian movement LOS values are based on average delay per pedestrian movement.

Intersection LOS value for Pedestrians is based on average delay for all pedestrian movements.

SIDRA INTERSECTION 9.1 | Copyright © 2000-2024 Akcelik and Associates Pty Ltd | sidrasolutions.com

Organisation: AJW | Licence: NETWORK / 1PC | Processed: Friday, 27 March 2026 7:45:56 pm

Project: C:\Users\annaj\OneDrive\AW Consulting\Projects\Boffa Miskell Jobs\Wairakei South\ITA Work Feb 2026\Final SIDRA Modelling\Third Round Base Sidra File\2063_TTHM 10D Mitigated.sip9

MOVEMENT SUMMARY

 Site: 101 [1348 Bell Rd Parton Rd AM (Site Folder: General)]

Output produced by SIDRA INTERSECTION Version: 9.1.6.228

 Network: N101
[2063_Opt10D_AM (Network Folder: General)]

New Site
Site Category: (None)
Stop (Two-Way)

Vehicle Movement Performance															
Mov ID	Turn	Mov Class	Demand Flows		Arrival Flows		Deg. Satn	Aver. Delay	Level of Service	Aver. Back of Queue	Prop. Que	Eff. Stop Rate	Aver. No. of Cycles	Aver. Speed	
			[Total HV] veh/h	%	[Total HV] veh/h	%									v/c
East: Bell Road															
5	T1	All MCs	363	5.1	361	5.1	0.191	0.1	LOS A	0.0	0.0	0.00	0.00	0.00	99.9
6	R2	All MCs	135	5.1	134	5.1	0.163	11.2	LOS B	0.3	2.0	0.61	0.83	0.61	87.1
Approach			498	5.1	494	5.1	0.191	3.1	NA	0.3	2.0	0.17	0.23	0.17	95.6
North: Parton Road															
7	L2	All MCs	174	5.1	174	5.1	0.579	17.0	LOS C	1.4	10.6	0.76	1.12	1.31	52.4
9	R2	All MCs	167	5.1	167	5.1	0.579	20.4	LOS C	1.4	10.6	0.76	1.12	1.31	52.4
Approach			341	5.1	341	5.1	0.579	18.7	LOS C	1.4	10.6	0.76	1.12	1.31	52.4
West: Bell Road															
10	L2	All MCs	103	5.1	103	5.1	0.354	8.0	LOS A	0.0	0.0	0.00	0.11	0.00	84.6
11	T1	All MCs	560	5.1	560	5.1	0.354	0.1	LOS A	0.0	0.0	0.00	0.11	0.00	95.1
Approach			663	5.1	663	5.1	0.354	1.3	NA	0.0	0.0	0.00	0.11	0.00	92.4
All Vehicles			1502	5.1	1499	5.1	0.579	5.8	NA	1.4	10.6	0.23	0.38	0.35	88.9

Site Level of Service (LOS) Method: Delay (SIDRA). Site LOS Method is specified in the Network Data dialog (Override Site Data tab).

Vehicle movement LOS values are based on average delay per movement.

Minor Road Approach LOS values are based on average delay for all vehicle movements.

NA (TWSC): Level of Service is not defined for major road approaches or the intersection as a whole for Two-Way Sign Control (HCM LOS rule).

Two-Way Sign Control Capacity Model: SIDRA Standard.

Delay Model: SIDRA Standard (Control Delay: Geometric Delay is included).

Queue Model: SIDRA queue estimation methods are used for Back of Queue and Queue at Start of Gap.

Gap-Acceptance Capacity Formula: SIDRA Standard (Akçelik M3D).

HV (%) values are calculated for All Movement Classes of All Heavy Vehicle Model Designation.

Arrival Flows used in performance calculations are adjusted to include any Initial Queued Demand and Upstream Capacity Constraint effects.

SIDRA INTERSECTION 9.1 | Copyright © 2000-2024 Akcelik and Associates Pty Ltd | sidrasolutions.com

Organisation: BOFFA MISKELL | Licence: NETWORK / 1PC | Processed: Saturday, 28 March 2026 1:55:49 pm

Project: U:\2025\BM250088_BSa_Wairakei_South_Masterplan\Documents\Transport\Modelling\Sidra Network\260328 Sidra Models for ITA from Anna\2063_TTHM 10D Mitigated_v1.sip9

USER REPORT FOR NETWORK SITE

Project: 2063_TTHM 10D Mitigated_v1

Template: Default Site User Report

 Site: 101 [1348 Bell Rd Parton Rd AM (Site Folder: General)]

 Network: 1 [2063_Opt10D_AM (Network Folder: General)]

New Site
Site Category: (None)
Stop (Two-Way)

Site Layout

Layout pictures are schematic functional drawings reflecting input data. They are not design drawings.

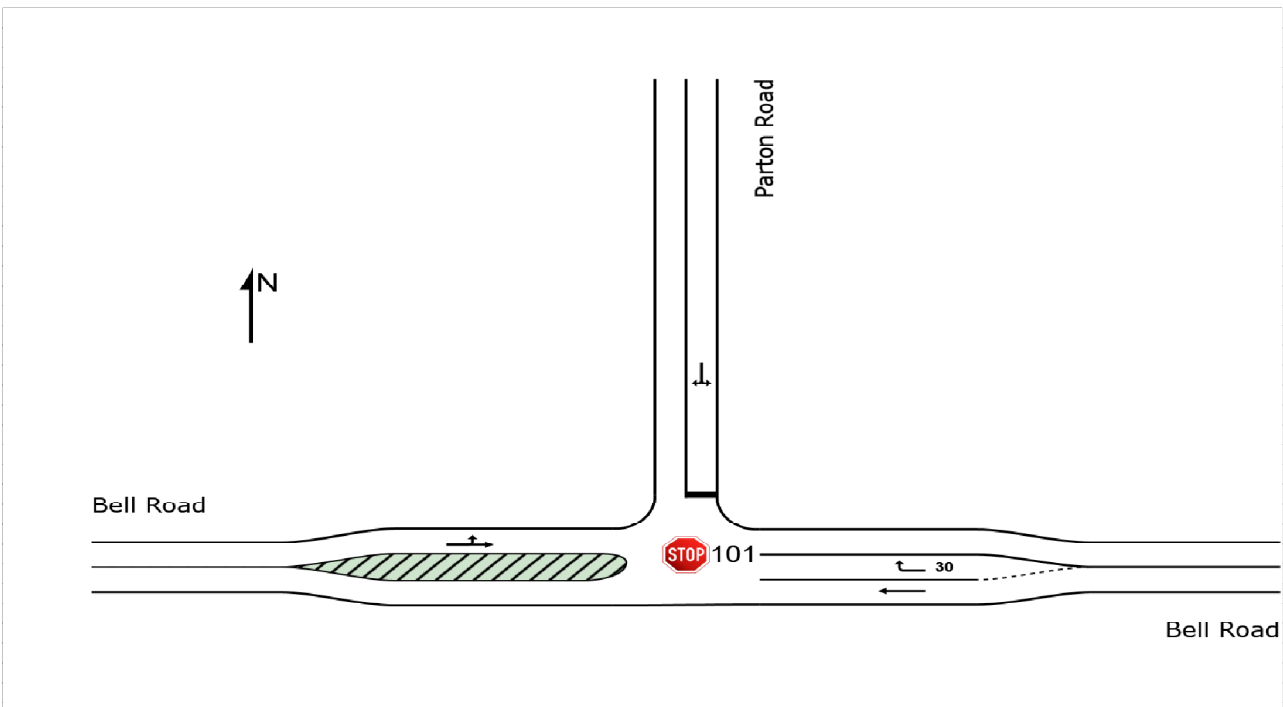

SIDRA INTERSECTION 9.1 | Copyright © 2000-2024 Akcelik and Associates Pty Ltd | sidrasolutions.com

Organisation: BOFFA MISKELL | Licence: NETWORK / 1PC | Created: Thursday, 23 April 2026 3:12:51 pm

Project: U:\2025\BM250088_BSa_Wairakei_South_Masterplan\Documents\Transport\Modelling\Sidra Network\260328 Sidra Models for ITA from Anna\2063_TTHM 10D Mitigated_v1.sip9

MOVEMENT SUMMARY

 Site: 101 [1348 Bell Rd Parton Rd AM (Site Folder: General)]

Output produced by SIDRA INTERSECTION Version: 9.1.6.228

 Network: N101
[2063_Opt10D_AM (Network Folder: General)]

New Site
Site Category: (None)
Stop (Two-Way)

Vehicle Movement Performance															
Mov ID	Turn	Mov Class	Demand Flows		Arrival Flows		Deg. Satn	Aver. Delay	Level of Service	Aver. Back Of Queue	Prop. Que		Eff. Stop Rate	Aver. No. of Cycles	Aver. Speed km/h
			[Total HV] veh/h	%	[Total HV] veh/h	%					[Veh. veh	[Dist] m			
East: Bell Road															
5	T1	All MCs	363	5.1	361	5.1	0.191	0.1	LOS A	0.0	0.0	0.00	0.00	0.00	99.9
6	R2	All MCs	135	5.1	134	5.1	0.163	11.4	LOS B	0.3	2.0	0.61	0.83	0.61	87.0
Approach			498	5.1	494	5.1	0.191	3.2	NA	0.3	2.0	0.17	0.22	0.17	95.6
North: Parton Road															
7	L2	All MCs	174	5.1	174	5.1	0.242	13.7	LOS B	0.4	2.9	0.59	0.97	0.60	60.3
9	R2	All MCs	167	5.1	167	5.1	0.337	17.3	LOS C	0.5	3.9	0.75	1.04	0.94	54.3
Approach			341	5.1	341	5.1	0.337	15.5	LOS C	0.5	3.9	0.67	1.00	0.77	57.2
West: Bell Road															
10	L2	All MCs	103	5.1	103	5.1	0.354	8.0	LOS A	0.0	0.0	0.00	0.11	0.00	84.6
11	T1	All MCs	560	5.1	560	5.1	0.354	0.1	LOS A	0.0	0.0	0.00	0.11	0.00	95.2
Approach			663	5.1	663	5.1	0.354	1.3	NA	0.0	0.0	0.00	0.11	0.00	92.4
All Vehicles			1502	5.1	1499	5.1	0.354	5.1	NA	0.5	3.9	0.21	0.35	0.23	89.9

Site Level of Service (LOS) Method: Delay (SIDRA). Site LOS Method is specified in the Network Data dialog (Override Site Data tab).

Vehicle movement LOS values are based on average delay per movement.

Minor Road Approach LOS values are based on average delay for all vehicle movements.

NA (TWSC): Level of Service is not defined for major road approaches or the intersection as a whole for Two-Way Sign Control (HCM LOS rule).

Two-Way Sign Control Capacity Model: SIDRA Standard.

Delay Model: SIDRA Standard (Control Delay: Geometric Delay is included).

Queue Model: SIDRA queue estimation methods are used for Back of Queue and Queue at Start of Gap.

Gap-Acceptance Capacity Formula: SIDRA Standard (Akçelik M3D).

HV (%) values are calculated for All Movement Classes of All Heavy Vehicle Model Designation.

Arrival Flows used in performance calculations are adjusted to include any Initial Queued Demand and Upstream Capacity Constraint effects.

SIDRA INTERSECTION 9.1 | Copyright © 2000-2024 Akcelik and Associates Pty Ltd | sidrasolutions.com

Organisation: AJW | Licence: NETWORK / 1PC | Processed: Friday, 27 March 2026 9:45:56 pm

Project: U:\2025\BM250088_BSa_Wairakei_South_Masterplan\Documents\Transport\Modelling\Sidra Network\260328 Sidra Models for ITA from Anna\2063_TTHM 10D Mitigated.sip9

MOVEMENT SUMMARY

Site: 101v [2140 Te Puke Hwy Bell Rd AM Signals (Site Folder: General)]

Output produced by SIDRA INTERSECTION Version: 9.1.6.228

Network: N101
[2063_Opt10D_AM (Network Folder: General)]

New Site

Site Category: (None)

Signals - EQUISAT (Fixed-Time/SCATS) Isolated Cycle Time = 50 seconds (Site Practical Cycle Time)

Vehicle Movement Performance															
Mov ID	Turn	Mov Class	Demand Flows		Arrival Flows		Deg. Satn	Aver. Delay	Level of Service	Aver. Back Of Queue	Prop. Que	Eff. Stop Rate	Aver. No. of Cycles	Aver. Speed	
			[Total HV] veh/h	%	[Total HV] veh/h	%									v/c
South: Te Puke Hwy															
2	T1	All MCs	489	6.4	489	6.4	0.422	5.3	LOS A	3.8	28.1	0.55	0.48	0.55	99.1
3	R2	All MCs	252	6.4	252	6.4	*0.787	33.7	LOS C	4.2	31.0	1.00	0.91	1.30	94.2
Approach			741	6.4	741	6.4	0.787	14.9	LOS B	4.2	31.0	0.70	0.63	0.80	97.4
East: Bell Road															
4	L2	All MCs	357	6.4	355	6.4	0.358	13.0	LOS B	2.4	17.5	0.58	0.76	0.58	96.7
6	R2	All MCs	177	6.4	176	6.4	*0.708	33.6	LOS C	2.8	21.0	1.00	0.86	1.20	51.8
Approach			534	6.4	531	6.4	0.708	19.8	LOS B	2.8	21.0	0.72	0.79	0.79	93.7
North: Te Puke Hwy															
7	L2	All MCs	407	6.4	407	6.4	0.343	11.1	LOS B	2.0	14.5	0.47	0.73	0.47	62.8
8	T1	All MCs	663	6.4	663	6.4	*0.742	17.7	LOS B	6.6	48.8	0.90	0.80	0.99	97.0
Approach			1071	6.4	1071	6.4	0.742	15.2	LOS B	6.6	48.8	0.74	0.78	0.79	95.9
All Vehicles			2345	6.4	2343	6.4	0.787	16.2	LOS B	6.6	48.8	0.72	0.73	0.79	96.0

Site Level of Service (LOS) Method: Delay (SIDRA). Site LOS Method is specified in the Network Data dialog (Override Site Data tab).

Vehicle movement LOS values are based on average delay per movement.

Intersection and Approach LOS values are based on average delay for all vehicle movements.

Delay Model: SIDRA Standard (Control Delay: Geometric Delay is included).

Queue Model: SIDRA queue estimation methods are used for Back of Queue and Queue at Start of Green.

Gap-Acceptance Capacity Formula: SIDRA Standard (Akçelik M3D).

HV (%) values are calculated for All Movement Classes of All Heavy Vehicle Model Designation.

Arrival Flows used in performance calculations are adjusted to include any Initial Queued Demand and Upstream Capacity Constraint effects.

* Critical Movement (Signal Timing)

SIDRA INTERSECTION 9.1 | Copyright © 2000-2024 Akcelik and Associates Pty Ltd | sidrasolutions.com

Organisation: AJW | Licence: NETWORK / 1PC | Processed: Friday, 27 March 2026 7:45:56 pm

Project: C:\Users\annaj\OneDrive\AW Consulting\Projects\Boffa Miskell Jobs\Wairakei South\ITA Work Feb 2026\Final SIDRA Modelling\Third Round Base Sidra File\2063_TTHM 10D Mitigated.sip9

MOVEMENT SUMMARY

Site: 10013a [10013_AM (Site Folder: General)]

Output produced by SIDRA INTERSECTION Version: 9.1.6.228

Network: N101
[2063_Opt10D_AM (Network Folder: General)]

Site Category: (None)
Roundabout

Vehicle Movement Performance															
Mov ID	Turn	Mov Class	Demand Flows		Arrival Flows		Deg. Satn	Aver. Delay	Level of Service	Aver. Back Of Queue		Prop. Que	Eff. Stop Rate	Aver. No. of Cycles	Aver. Speed
			[Total HV]	%	[Total HV]	%				[Veh. veh	Dist]				
			veh/h	%	veh/h	%	v/c	sec			m				km/h
South: Road 4															
1	L2	All MCs	248	5.7	248	5.7	0.428	4.5	LOS A	1.3	9.3	0.57	0.54	0.57	41.2
2	T1	All MCs	101	5.7	101	5.7	0.428	4.3	LOS A	1.3	9.3	0.57	0.54	0.57	43.5
3	R2	All MCs	129	5.7	129	5.7	0.428	9.3	LOS A	1.3	9.3	0.57	0.54	0.57	41.2
Approach			479	5.7	479	5.7	0.428	5.7	LOS A	1.3	9.3	0.57	0.54	0.57	41.8
East: Bell Road															
4	L2	All MCs	85	5.7	83	5.8	0.255	5.5	LOS A	0.5	4.0	0.51	0.59	0.51	45.0
5	T1	All MCs	129	5.7	126	5.8	0.255	5.3	LOS A	0.5	4.0	0.51	0.59	0.51	42.6
6	R2	All MCs	19	5.7	18	5.8	0.255	10.3	LOS B	0.5	4.0	0.51	0.59	0.51	43.4
Approach			234	5.7	227	5.8	0.255	5.8	LOS A	0.5	4.0	0.51	0.59	0.51	43.8
North: Road 4															
7	L2	All MCs	1	5.7	1	5.7	0.220	7.1	LOS A	0.6	4.2	0.77	0.72	0.77	32.5
8	T1	All MCs	40	5.7	40	5.7	0.220	6.9	LOS A	0.6	4.2	0.77	0.72	0.77	40.5
9	R2	All MCs	116	5.7	116	5.7	0.220	11.8	LOS B	0.6	4.2	0.77	0.72	0.77	32.5
Approach			157	5.7	157	5.7	0.220	10.5	LOS B	0.6	4.2	0.77	0.72	0.77	35.7
West: Bell Road															
10	L2	All MCs	191	5.7	191	5.7	0.651	5.4	LOS A	2.7	19.6	0.73	0.62	0.76	48.1
11	T1	All MCs	231	5.7	231	5.7	0.651	5.2	LOS A	2.7	19.6	0.73	0.62	0.76	48.1
12	R2	All MCs	318	5.7	318	5.7	0.651	10.1	LOS B	2.7	19.6	0.73	0.62	0.76	48.0
Approach			739	5.7	739	5.7	0.651	7.4	LOS A	2.7	19.6	0.73	0.62	0.76	48.1
All Vehicles			1608	5.7	1602	5.7	0.651	7.0	LOS A	2.7	19.6	0.66	0.60	0.67	46.9

Site Level of Service (LOS) Method: Delay (SIDRA). Site LOS Method is specified in the Network Data dialog (Override Site Data tab).

Roundabout LOS Method: SIDRA Roundabout LOS.

Vehicle movement LOS values are based on average delay per movement.

Intersection and Approach LOS values are based on average delay for all vehicle movements.

Roundabout Capacity Model: SIDRA Standard.

Delay Model: SIDRA Standard (Control Delay: Geometric Delay is included).

Queue Model: SIDRA queue estimation methods are used for Back of Queue and Queue at Start of Gap.

Gap-Acceptance Capacity Formula: SIDRA Standard (Akçelik M3D).

HV (%) values are calculated for All Movement Classes of All Heavy Vehicle Model Designation.

Arrival Flows used in performance calculations are adjusted to include any Initial Queued Demand and Upstream Capacity Constraint effects.

SIDRA INTERSECTION 9.1 | Copyright © 2000-2024 Akcelik and Associates Pty Ltd | sidrasolutions.com

Organisation: AJW | Licence: NETWORK / 1PC | Processed: Friday, 27 March 2026 7:45:56 pm

Project: C:\Users\lannaj\OneDrive\AW Consulting\Projects\Boffa Miskell Jobs\Wairakei South\ITA Work Feb 2026\Final SIDRA Modelling\Third Round Base Sidra File\2063_TTHM 10D Mitigated.sip9

MOVEMENT SUMMARY

Site: 99a [MIBA Internal Roundabout AM (Site Folder: General)]

Output produced by SIDRA INTERSECTION Version: 9.1.6.228

Network: N101
[2063_Opt10D_AM (Network Folder: General)]

New Site
Site Category: (None)
Roundabout

Vehicle Movement Performance															
Mov ID	Turn	Mov Class	Demand Flows		Arrival Flows		Deg. Satn	Aver. Delay	Level of Service	Aver. Back Of Queue		Prop. Que	Eff. Stop Rate	Aver. No. of Cycles	Aver. Speed
			[Total HV] veh/h	%	[Total HV] veh/h	%				[Veh. veh	[Dist] m				
South: Internal Road South															
1	L2	All MCs	86	5.0	86	5.0	0.099	4.6	LOSA	0.2	1.5	0.33	0.53	0.33	43.6
2	T1	All MCs	1	5.0	1	5.0	0.099	4.5	LOSA	0.2	1.5	0.33	0.53	0.33	45.8
3	R2	All MCs	20	5.0	20	5.0	0.099	7.7	LOSA	0.2	1.5	0.33	0.53	0.33	43.5
Approach			107	5.0	107	5.0	0.099	5.2	LOSA	0.2	1.5	0.33	0.53	0.33	43.6
East: Latham Drive East															
4	L2	All MCs	115	5.0	115	5.0	0.184	4.6	LOSA	0.4	3.0	0.34	0.52	0.34	43.7
5	T1	All MCs	44	5.0	44	5.0	0.184	4.5	LOSA	0.4	3.0	0.34	0.52	0.34	36.7
6	R2	All MCs	48	5.0	48	5.0	0.184	7.7	LOSA	0.4	3.0	0.34	0.52	0.34	43.4
Approach			207	5.0	207	5.0	0.184	5.3	LOSA	0.4	3.0	0.34	0.52	0.34	43.0
North: Internal Road North															
7	L2	All MCs	25	5.0	25	5.0	0.077	4.5	LOSA	0.2	1.2	0.32	0.57	0.32	42.8
8	T1	All MCs	1	5.0	1	5.0	0.077	4.4	LOSA	0.2	1.2	0.32	0.57	0.32	45.0
9	R2	All MCs	59	5.0	59	5.0	0.077	7.7	LOSA	0.2	1.2	0.32	0.57	0.32	42.2
Approach			85	5.0	85	5.0	0.077	6.7	LOSA	0.2	1.2	0.32	0.57	0.32	42.5
West: Latham Drive West															
10	L2	All MCs	96	5.0	93	5.0	0.174	4.1	LOSA	0.3	2.5	0.20	0.52	0.20	42.7
11	T1	All MCs	47	5.0	46	5.0	0.174	4.0	LOSA	0.3	2.5	0.20	0.52	0.20	38.0
12	R2	All MCs	80	5.0	78	5.0	0.174	7.2	LOSA	0.3	2.5	0.20	0.52	0.20	42.4
Approach			223	5.0	217	5.0	0.174	5.2	LOSA	0.3	2.5	0.20	0.52	0.20	42.0
All Vehicles			623	5.0	617	5.0	0.184	5.4	LOSA	0.4	3.0	0.29	0.53	0.29	42.7

Site Level of Service (LOS) Method: Delay (SIDRA). Site LOS Method is specified in the Network Data dialog (Override Site Data tab).

Roundabout LOS Method: SIDRA Roundabout LOS.

Vehicle movement LOS values are based on average delay per movement.

Intersection and Approach LOS values are based on average delay for all vehicle movements.

Roundabout Capacity Model: SIDRA Standard.

Delay Model: SIDRA Standard (Control Delay: Geometric Delay is included).

Queue Model: SIDRA queue estimation methods are used for Back of Queue and Queue at Start of Gap.

Gap-Acceptance Capacity Formula: SIDRA Standard (Akçelik M3D).

HV (%) values are calculated for All Movement Classes of All Heavy Vehicle Model Designation.

Arrival Flows used in performance calculations are adjusted to include any Initial Queued Demand and Upstream Capacity Constraint effects.

SIDRA INTERSECTION 9.1 | Copyright © 2000-2024 Akcelik and Associates Pty Ltd | sidrasolutions.com

Organisation: AJW | Licence: NETWORK / 1PC | Processed: Friday, 27 March 2026 7:45:56 pm

Project: C:\Users\annaj\OneDrive\AW Consulting\Projects\Boffa Miskell Jobs\Wairakei South\ITA Work Feb 2026\Final SIDRA Modelling\Third Round Base Sidra File\2063_TTHM 10D Mitigated.sip9

CCG PHASING SUMMARY

Common Control Group: CCG1 [CCG_1]

Output produced by SIDRA INTERSECTION Version: 9.1.6.228

Network: N101
[2063_Opt10D_AM (Network Folder: General)]

EQUISAT (Fixed-Time/SCATS) Coordinated Cycle Time = 120 seconds (Network Optimum Cycle Time - Minimum Delay)

Timings based on settings in the Network Timing dialog

Phase Times determined by the program

Downstream lane blockage effects included in determining phase times

Phase Sequence: CCG Phasing

Input Phase Sequence: A, B, C, D

Output Phase Sequence: A, B, C, D

Reference Phase: Phase A

Offset: 0 seconds (Program)

Phase Timing Summary (CCG)

Phase	A	B	C	D
Phase Change Time (sec)	0	33	56	90
Green Time (sec)	27	17	28	24
Phase Time (sec)	33	23	34	30
Phase Split	28%	19%	28%	25%
Phase Frequency (%)	100.0	100.0	100.0	100.0

See the Timing Analysis report for more detailed information including input values of Yellow Time and All-Red Time, and information on any adjustments to Intergreen Time, Phase Time and Green Time values in cases of Pedestrian Actuation, Minor Phase Actuation and Phase Frequency values (user-specified or implied) less than 100%.

Output Phase Sequence (CCG)

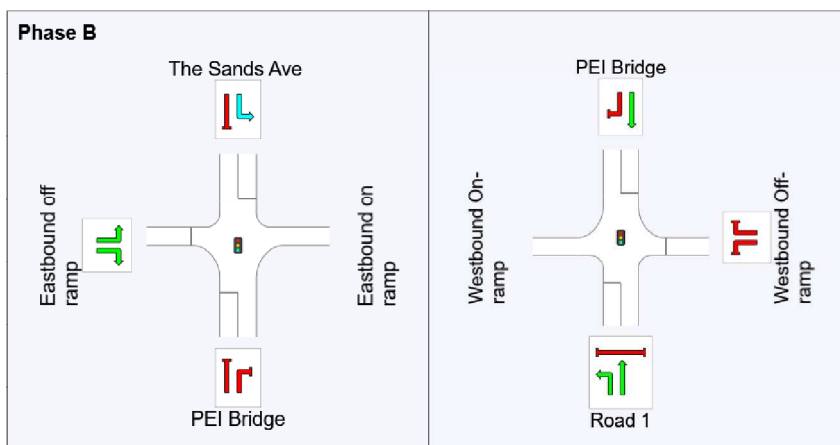
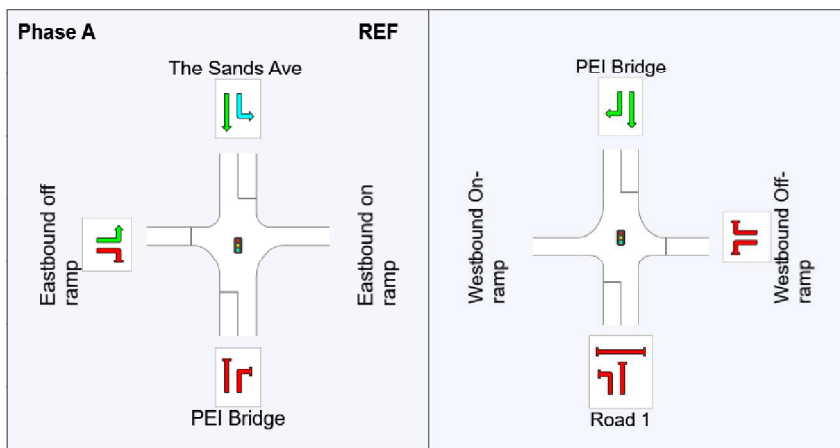

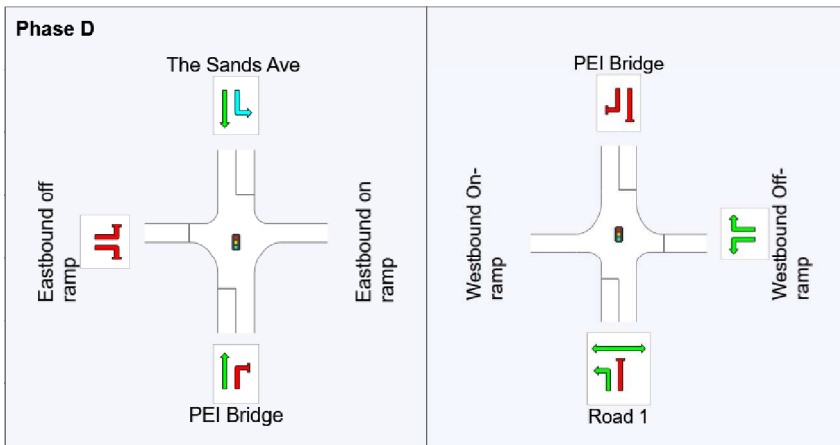
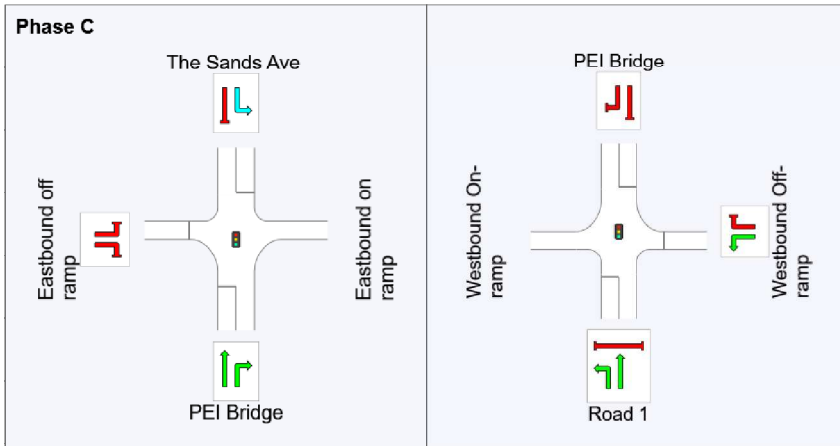

REF: Reference Phase
 VAR: Variable Phase

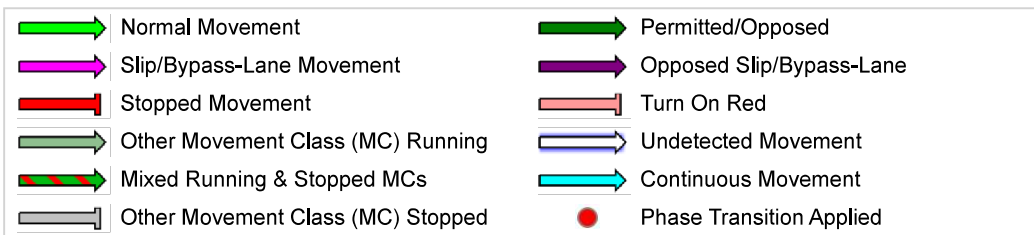

SIDRA INTERSECTION 9.1 | Copyright © 2000-2024 Akcelik and Associates Pty Ltd | sidrasolutions.com

Organisation: AJW | Licence: NETWORK / 1PC | Processed: Friday, 27 March 2026 7:45:56 pm

Project: C:\Users\annaj\OneDrive\AW Consulting\Projects\Boffa Miskell Jobs\Wairakei South\ITA Work Feb 2026\Final SIDRA Modelling\Third Round Base Sidra File\2063_TTHM 10D Mitigated.sip9

PHASING SUMMARY

Site: 2859a [2859 Boulv_TheSand_AM (Site Folder: General)]

Output produced by SIDRA INTERSECTION Version: 9.1.6.228

Network: N101
[2063_Opt10D_AM (Network Folder: General)]

Site Category: (None)

Signals - EQUISAT (Fixed-Time/SCATS) Coordinated Cycle Time = 120 seconds (Network Optimum Cycle Time - Minimum Delay)

Timings based on settings in the Network Timing dialog

Phase Times determined by the program

Downstream lane blockage effects included in determining phase times

Green Split Priority has been specified

Phase Sequence: DDO - Copy

Input Phase Sequence: A, B*, C*, D, D1*, E, F, F1*

Output Phase Sequence: A, B*, D, D1*, E, F, F1*

Reference Phase: Phase A

Offset: 37 seconds (Program)

(* Variable Phase)

Phase Timing Summary

Phase	A	B	D	D1	E	F	F1
Phase Change Time (sec)	42	65	92	104	115	7	31
Green Time (sec)	22	21	6	5	6	18	5
Phase Time (sec)	28	27	12	11	12	24	6
Phase Split	23%	23%	10%	9%	10%	20%	5%
Phase Frequency (%)	100.0	100.0	100.0	100.0	100.0	100.0	23.1 ³

See the Timing Analysis report for more detailed information including input values of Yellow Time and All-Red Time, and information on any adjustments to Intergreen Time, Phase Time and Green Time values in cases of Pedestrian Actuation, Minor Phase Actuation and Phase Frequency values (user-specified or implied) less than 100%.

³ Phase Frequency has been estimated from actuated movement probabilities.

Output Phase Sequence

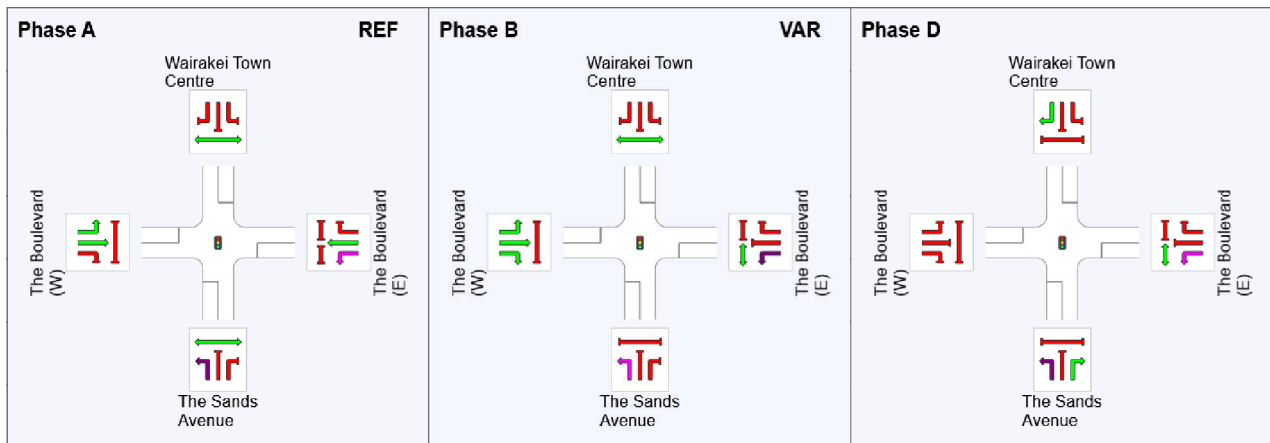

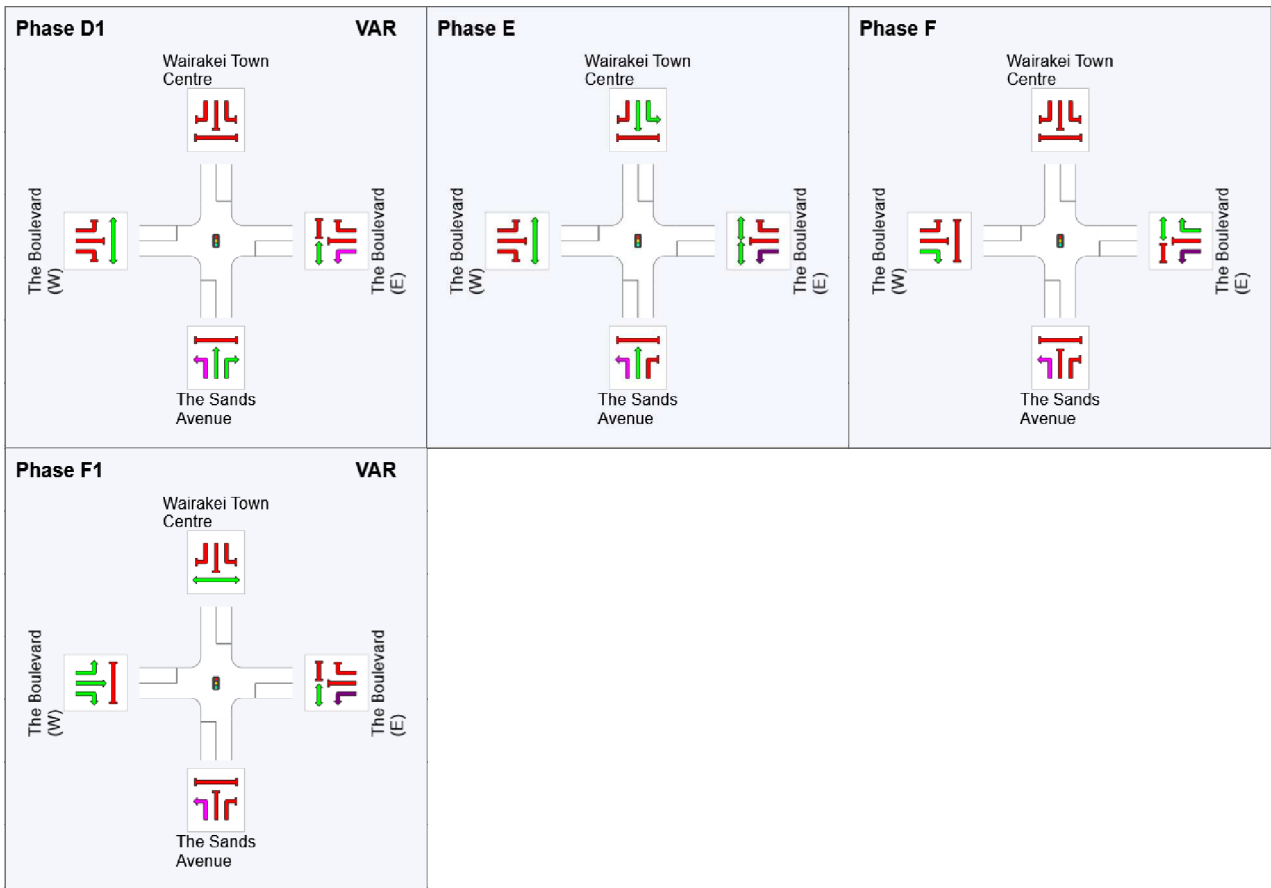

REF: Reference Phase
 VAR: Variable Phase



SIDRA INTERSECTION 9.1 | Copyright © 2000-2024 Akcelik and Associates Pty Ltd | sidrasolutions.com

Organisation: AJW | Licence: NETWORK / 1PC | Processed: Friday, 27 March 2026 7:45:56 pm

Project: C:\Users\anna\OneDrive\AW Consulting\Projects\Boffa Miskell Jobs\Wairakei South\ITA Work Feb 2026\Final SIDRA Modelling\Third Round Base Sidra File\2063_TTHM 10D Mitigated.sip9

PHASING SUMMARY

Site: 2860a [2860 The Sand_Bill Miller_AM (Site Folder: General)]

Output produced by SIDRA INTERSECTION Version: 9.1.6.228

Network: N101
[2063_Opt10D_AM (Network Folder: General)]

Site Category: (None)

Signals - EQUISAT (Fixed-Time/SCATS) Coordinated Cycle Time = 120 seconds (Network Optimum Cycle Time - Minimum Delay)

Timings based on settings in the Network Timing dialog

Phase Times determined by the program

Downstream lane blockage effects included in determining phase times

Green Split Priority has been specified

Phase Sequence: DDO - Copy (phase reduction applied)

Input Phase Sequence: A, D, E, F

Output Phase Sequence: A, D, F

Reference Phase: Phase A

Offset: 89 seconds (Program)

Phase Timing Summary

Phase	A	D	F
Phase Change Time (sec)	89	50	77
Green Time (sec)	75	21	6
Phase Time (sec)	81	27	12
Phase Split	68%	23%	10%
Phase Frequency (%)	100.0	100.0	100.0





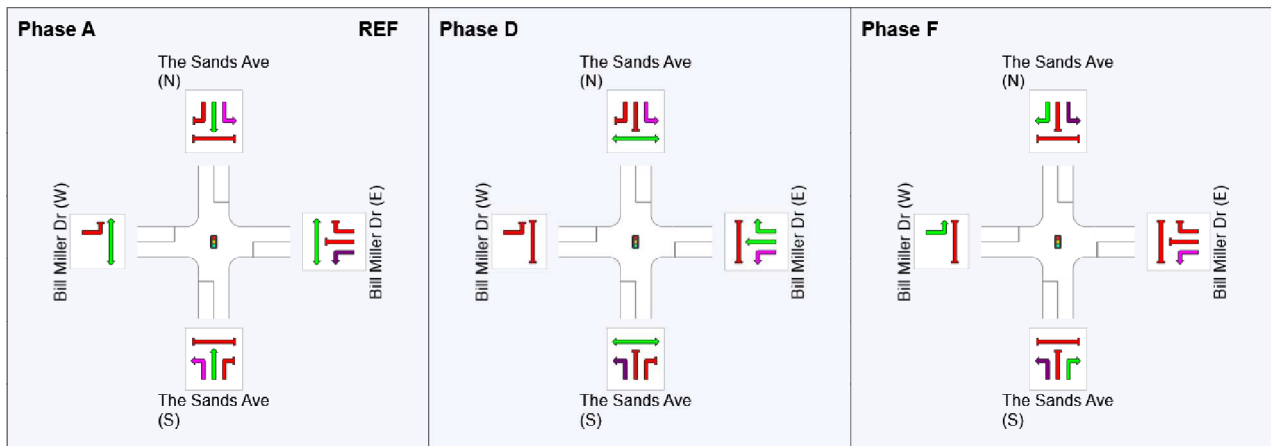







See the Timing Analysis report for more detailed information including input values of Yellow Time and All-Red Time, and information on any adjustments to Intergreen Time, Phase Time and Green Time values in cases of Pedestrian Actuation, Minor Phase Actuation and Phase Frequency values (user-specified or implied) less than 100%.

Output Phase Sequence



REF: Reference Phase

VAR: Variable Phase

	Normal Movement		Permitted/Opposed
	Slip/Bypass-Lane Movement		Opposed Slip/Bypass-Lane
	Stopped Movement		Turn On Red
	Other Movement Class (MC) Running		Undetected Movement
	Mixed Running & Stopped MCs		Continuous Movement
	Other Movement Class (MC) Stopped		Phase Transition Applied

SIDRA INTERSECTION 9.1 | Copyright © 2000-2024 Akcelik and Associates Pty Ltd | sidrasolutions.com

Organisation: AJW | Licence: NETWORK / 1PC | Processed: Friday, 27 March 2026 7:45:56 pm

Project: C:\Users\annaj\OneDrive\AW Consulting\Projects\Boffa Miskell Jobs\Wairakei South\ITA Work Feb 2026\Final SIDRA Modelling\Third Round Base Sidra File\2063_TTHM 10D Mitigated.sip9

PHASING SUMMARY

Site: 2514a [2514 Sands_Te Okuroa_AM (Site Folder: General)]

Output produced by SIDRA INTERSECTION Version: 9.1.6.228

Network: N101
[2063_Opt10D_AM (Network Folder: General)]

Site Category: (None)

Signals - EQUISAT (Fixed-Time/SCATS) Coordinated Cycle Time = 120 seconds (Network Optimum Cycle Time - Minimum Delay)

Timings based on settings in the Network Timing dialog

Phase Times determined by the program

Downstream lane blockage effects not included in determining phase times

Phase Sequence: Variable Phasing

Input Phase Sequence: A, D, E, F

Output Phase Sequence: A, D, E, F

Reference Phase: Phase A

Offset: 77 seconds (Program)

Phase Timing Summary

Phase	A	D	E	F
Phase Change Time (sec)	77	111	14	39
Green Time (sec)	28	17	19	32
Phase Time (sec)	34	23	25	38
Phase Split	28%	19%	21%	32%
Phase Frequency (%)	100.0	100.0	100.0	100.0

See the Timing Analysis report for more detailed information including input values of Yellow Time and All-Red Time, and information on any adjustments to Intergreen Time, Phase Time and Green Time values in cases of Pedestrian Actuation, Minor Phase Actuation and Phase Frequency values (user-specified or implied) less than 100%.

Output Phase Sequence

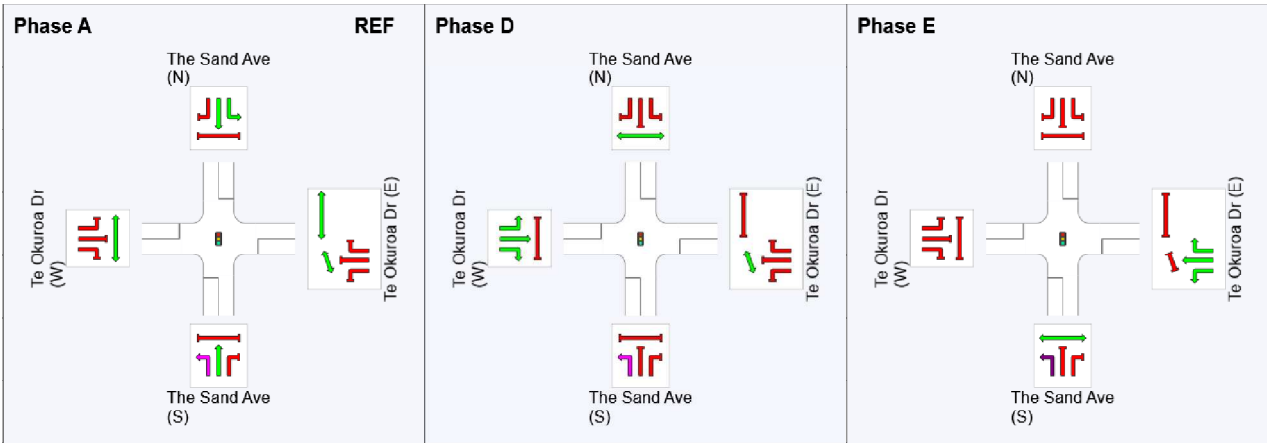

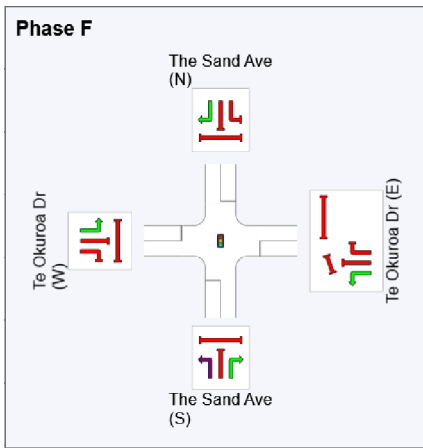

REF: Reference Phase
 VAR: Variable Phase



SIDRA INTERSECTION 9.1 | Copyright © 2000-2024 Kcelik and Associates Pty Ltd | sidrasolutions.com

Organisation: AJW | Licence: NETWORK / 1PC | Processed: Friday, 27 March 2026 7:45:56 pm

Project: C:\Users\annaj\OneDrive\AW Consulting\Projects\Boffa Miskell Jobs\Wairakei South\ITA Work Feb 2026\Final SIDRA Modelling\Third Round Base Sidra File\2063_TTHM 10D Mitigated.sip9

PHASING SUMMARY

Site: 10003a [10003_AM (Site Folder: General)]

Output produced by SIDRA INTERSECTION Version: 9.1.6.228

Network: N101
[2063_Opt10D_AM (Network Folder: General)]

NA

Site Category: (None)

Signals - EQUISAT (Fixed-Time/SCATS) Isolated Cycle Time = 110 seconds (Site Practical Cycle Time)

Timings based on settings in the Site Phasing & Timing dialog

Phase Times determined by the program

Downstream lane blockage effects included in determining phase times

Green Split Priority has been specified

Phase Sequence: Four-Phase Split Phasing

Input Phase Sequence: A, B, C, D

Output Phase Sequence: A, B, C, D

Reference Phase: Phase A

Offset: 0 seconds (User)

Phase Timing Summary





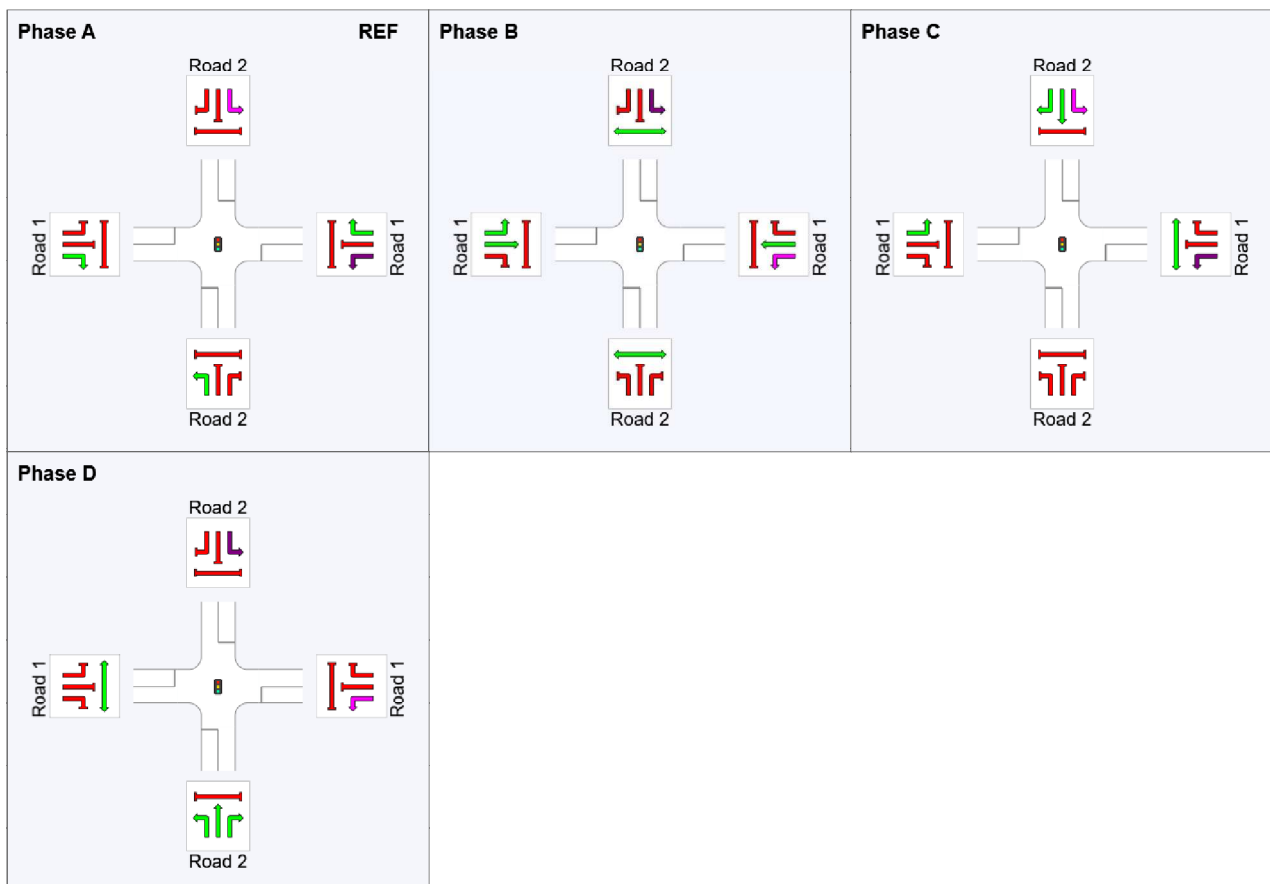

Phase	A	B	C	D
Phase Change Time (sec)	0	12	69	89
Green Time (sec)	6	51	14	15
Phase Time (sec)	12	57	20	21
Phase Split	11%	52%	18%	19%
Phase Frequency (%)	100.0	100.0	100.0	100.0

See the Timing Analysis report for more detailed information including input values of Yellow Time and All-Red Time, and information on any adjustments to Intergreen Time, Phase Time and Green Time values in cases of Pedestrian Actuation, Minor Phase Actuation and Phase Frequency values (user-specified or implied) less than 100%.

Output Phase Sequence



REF: Reference Phase
VAR: Variable Phase

	Normal Movement		Permitted/Opposed
	Slip/Bypass-Lane Movement		Opposed Slip/Bypass-Lane
	Stopped Movement		Turn On Red
	Other Movement Class (MC) Running		Undetected Movement
	Mixed Running & Stopped MCs		Continuous Movement
	Other Movement Class (MC) Stopped		Phase Transition Applied

SIDRA INTERSECTION 9.1 | Copyright © 2000-2024 Akcelik and Associates Pty Ltd | sidrasolutions.com

Organisation: AJW | Licence: NETWORK / 1PC | Processed: Friday, 27 March 2026 7:45:56 pm

Project: C:\Users\anna\OneDrive\AW Consulting\Projects\Boffa Miskell Jobs\Wairakei South\ITA Work Feb 2026\Final SIDRA Modelling\Third Round Base Sidra File\2063_TTHM 10D Mitigated.sip9

PHASING SUMMARY

Site: 10007a [10007_AM (Site Folder: General)]

Output produced by SIDRA INTERSECTION Version: 9.1.6.228

Network: N101
[2063_Opt10D_AM (Network Folder: General)]

NA

Site Category: (None)

Signals - EQUISAT (Fixed-Time/SCATS) Isolated Cycle Time = 70 seconds (Site Practical Cycle Time)

Timings based on settings in the Site Phasing & Timing dialog

Phase Times determined by the program

Downstream lane blockage effects included in determining phase times

Phase Sequence: Four-Phase Leading Right Turns

Input Phase Sequence: A, B, C, D

Output Phase Sequence: A, B, C, D

Reference Phase: Phase B

Offset: 0 seconds (User)

Phase Timing Summary





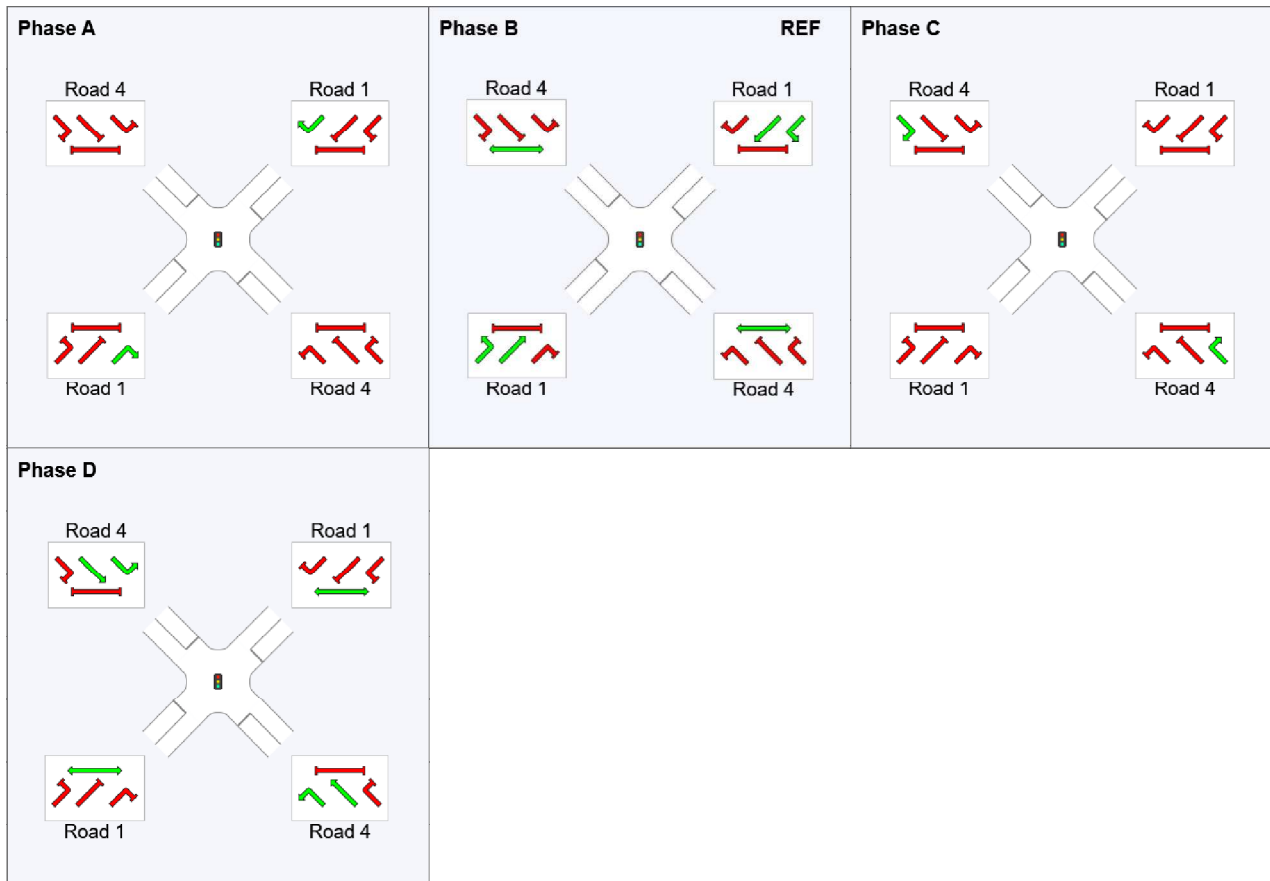

Phase	A	B	C	D
Phase Change Time (sec)	57	0	17	29
Green Time (sec)	7	11	6	22
Phase Time (sec)	13	17	12	28
Phase Split	19%	24%	17%	40%
Phase Frequency (%)	100.0	100.0	100.0	100.0

See the Timing Analysis report for more detailed information including input values of Yellow Time and All-Red Time, and information on any adjustments to Intergreen Time, Phase Time and Green Time values in cases of Pedestrian Actuation, Minor Phase Actuation and Phase Frequency values (user-specified or implied) less than 100%.

Output Phase Sequence



REF: Reference Phase
VAR: Variable Phase

	Normal Movement		Permitted/Opposed
	Slip/Bypass-Lane Movement		Opposed Slip/Bypass-Lane
	Stopped Movement		Turn On Red
	Other Movement Class (MC) Running		Undetected Movement
	Mixed Running & Stopped MCs		Continuous Movement
	Other Movement Class (MC) Stopped		Phase Transition Applied

PHASING SUMMARY

Site: 10008a [10008_AM (Site Folder: General)]

Output produced by SIDRA INTERSECTION Version: 9.1.6.228

Network: N101
[2063_Opt10D_AM (Network Folder: General)]

New Site

Site Category: (None)

Signals - EQUISAT (Fixed-Time/SCATS) Isolated Cycle Time = 70 seconds (Site Practical Cycle Time)

Timings based on settings in the Site Phasing & Timing dialog

Phase Times determined by the program

Downstream lane blockage effects included in determining phase times

Phase Sequence: Four-Phase Leading Right Turns

Input Phase Sequence: A, B, C, D

Output Phase Sequence: A, B, C, D

Reference Phase: Phase B

Offset: 0 seconds (User)

Phase Timing Summary







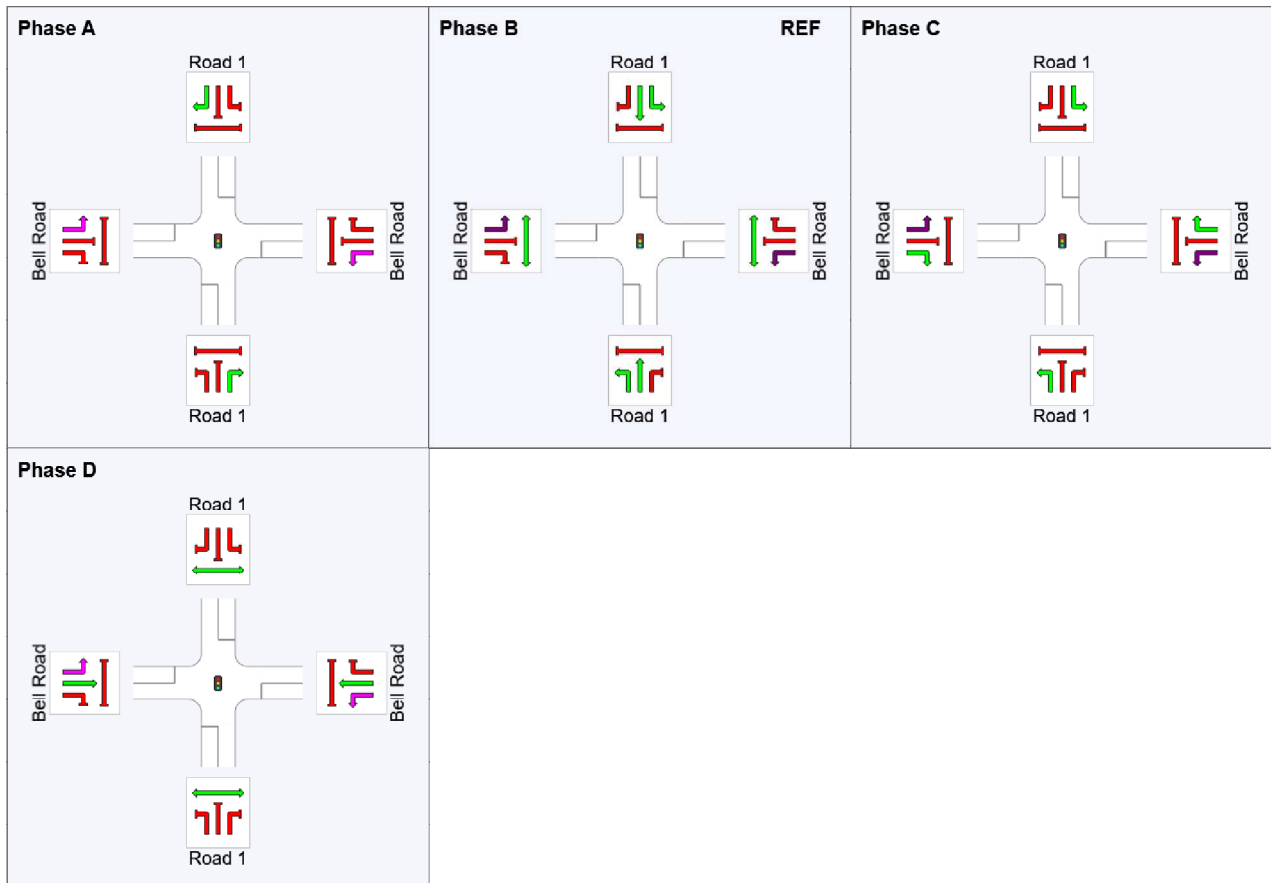

Phase	A	B	C	D
Phase Change Time (sec)	52	0	17	29
Green Time (sec)	12	11	6	17
Phase Time (sec)	18	17	12	23
Phase Split	26%	24%	17%	33%
Phase Frequency (%)	100.0	100.0	100.0	100.0

See the Timing Analysis report for more detailed information including input values of Yellow Time and All-Red Time, and information on any adjustments to Intergreen Time, Phase Time and Green Time values in cases of Pedestrian Actuation, Minor Phase Actuation and Phase Frequency values (user-specified or implied) less than 100%.

Output Phase Sequence



REF: Reference Phase
VAR: Variable Phase

	Normal Movement		Permitted/Opposed
	Slip/Bypass-Lane Movement		Opposed Slip/Bypass-Lane
	Stopped Movement		Turn On Red
	Other Movement Class (MC) Running		Undetected Movement
	Mixed Running & Stopped MCs		Continuous Movement
	Other Movement Class (MC) Stopped		Phase Transition Applied

PHASING SUMMARY

Site: 10015a [10015_AM (Site Folder: General)]

Output produced by SIDRA INTERSECTION Version: 9.1.6.228

Network: N101
[2063_Opt10D_AM (Network Folder: General)]

New Site

Site Category: (None)

Signals - EQUISAT (Fixed-Time/SCATS) Isolated Cycle Time = 70 seconds (Site Practical Cycle Time)

Timings based on settings in the Site Phasing & Timing dialog

Phase Times determined by the program

Downstream lane blockage effects included in determining phase times

Phase Sequence: Four-Phase Leading Right Turns

Input Phase Sequence: A, B, C, D

Output Phase Sequence: A, B, C, D

Reference Phase: Phase B

Offset: 0 seconds (User)

Phase Timing Summary







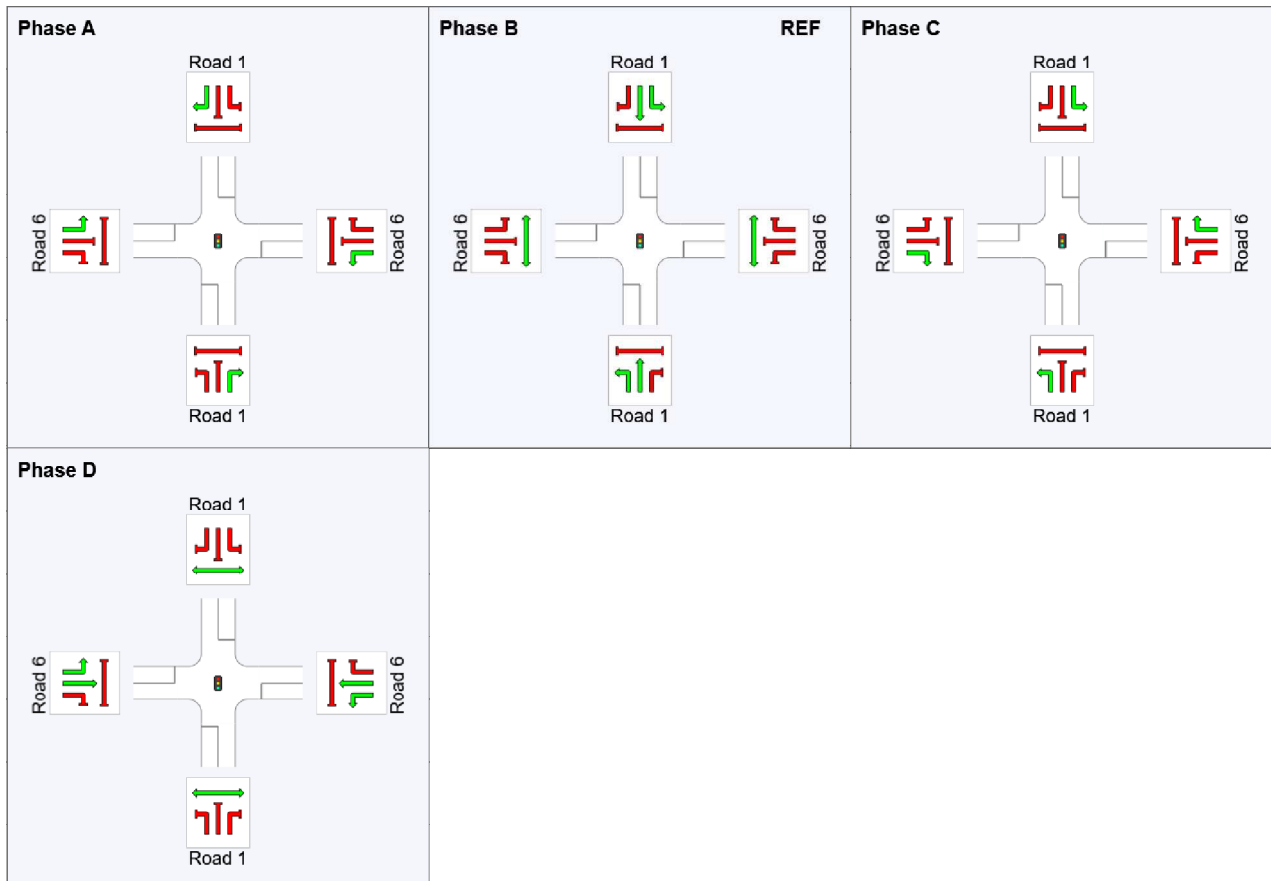



Phase	A	B	C	D
Phase Change Time (sec)	52	0	17	29
Green Time (sec)	12	11	6	17
Phase Time (sec)	18	17	12	23
Phase Split	26%	24%	17%	33%
Phase Frequency (%)	100.0	100.0	100.0	100.0

See the Timing Analysis report for more detailed information including input values of Yellow Time and All-Red Time, and information on any adjustments to Intergreen Time, Phase Time and Green Time values in cases of Pedestrian Actuation, Minor Phase Actuation and Phase Frequency values (user-specified or implied) less than 100%.

Output Phase Sequence



REF: Reference Phase
VAR: Variable Phase

	Normal Movement		Permitted/Opposed
	Slip/Bypass-Lane Movement		Opposed Slip/Bypass-Lane
	Stopped Movement		Turn On Red
	Other Movement Class (MC) Running		Undetected Movement
	Mixed Running & Stopped MCs		Continuous Movement
	Other Movement Class (MC) Stopped		Phase Transition Applied

PHASING SUMMARY

Site: 10016a [10016_AM (Site Folder: General)]

Output produced by SIDRA INTERSECTION Version: 9.1.6.228

Network: N101
[2063_Opt10D_AM (Network Folder: General)]

New Site

Site Category: (None)

Signals - EQUISAT (Fixed-Time/SCATS) Isolated Cycle Time = 60 seconds (Site Practical Cycle Time)

Timings based on settings in the Site Phasing & Timing dialog

Phase Times determined by the program

Downstream lane blockage effects included in determining phase times

Phase Sequence: Four-Phase Leading Right Turns

Input Phase Sequence: A, B, C, D

Output Phase Sequence: A, B, C, D

Reference Phase: Phase B

Offset: 0 seconds (User)

Phase Timing Summary







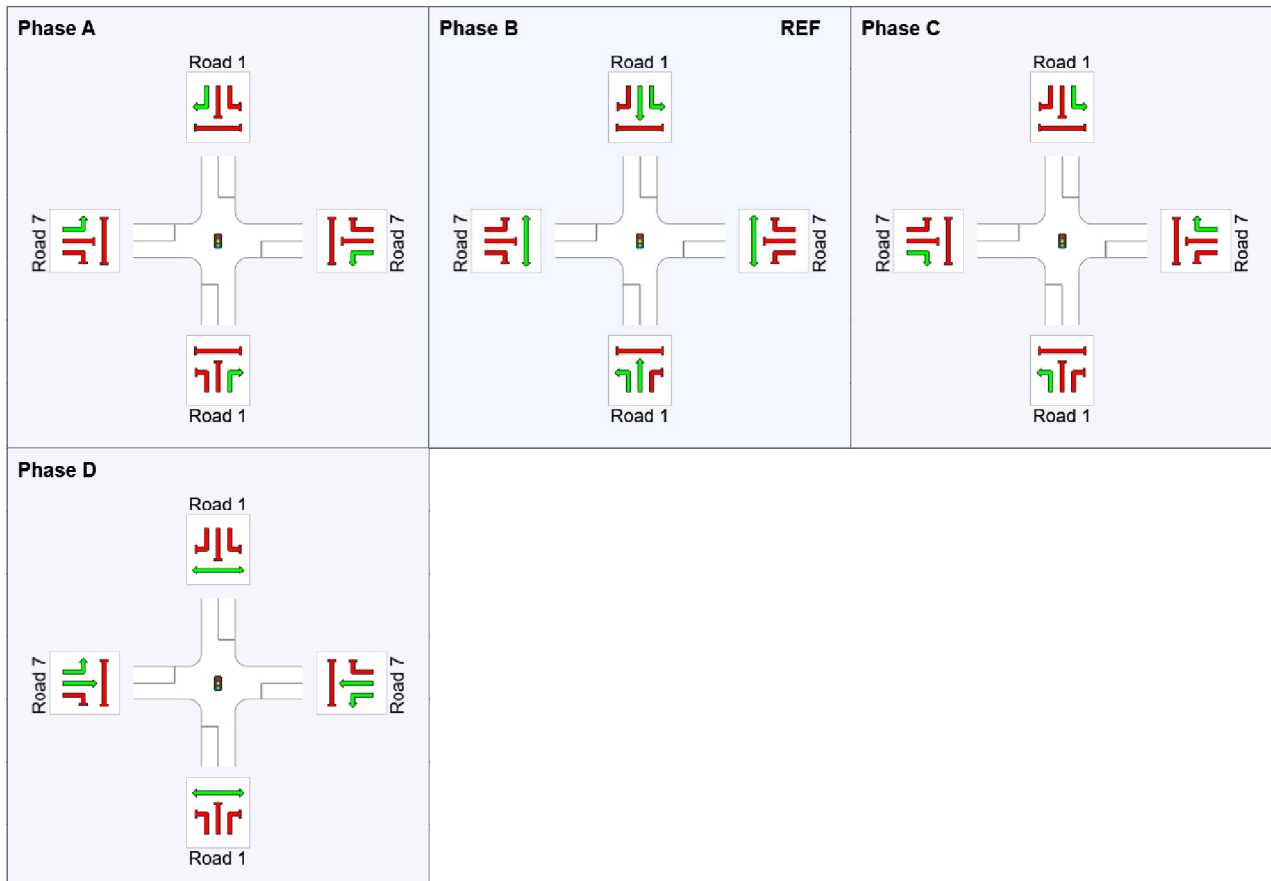





Phase	A	B	C	D
Phase Change Time (sec)	46	0	17	29
Green Time (sec)	8	11	6	11
Phase Time (sec)	14	17	12	17
Phase Split	23%	28%	20%	28%
Phase Frequency (%)	100.0	100.0	100.0	100.0

See the Timing Analysis report for more detailed information including input values of Yellow Time and All-Red Time, and information on any adjustments to Intergreen Time, Phase Time and Green Time values in cases of Pedestrian Actuation, Minor Phase Actuation and Phase Frequency values (user-specified or implied) less than 100%.

Output Phase Sequence



REF: Reference Phase
VAR: Variable Phase

	Normal Movement		Permitted/Opposed
	Slip/Bypass-Lane Movement		Opposed Slip/Bypass-Lane
	Stopped Movement		Turn On Red
	Other Movement Class (MC) Running		Undetected Movement
	Mixed Running & Stopped MCs		Continuous Movement
	Other Movement Class (MC) Stopped		Phase Transition Applied

PHASING SUMMARY

Site: 101v [2140 Te Puke Hwy Bell Rd AM Signals (Site Folder: General)]

Output produced by SIDRA INTERSECTION Version: 9.1.6.228

Network: N101
[2063_Opt10D_AM (Network Folder: General)]

New Site

Site Category: (None)

Signals - EQUISAT (Fixed-Time/SCATS) Isolated Cycle Time = 50 seconds (Site Practical Cycle Time)

Timings based on settings in the Site Phasing & Timing dialog

Phase Times determined by the program

Downstream lane blockage effects included in determining phase times

Phase Sequence: Convert Function Default

Input Phase Sequence: A, B, C

Output Phase Sequence: A, B, C

Reference Phase: Phase B

Offset: 0 seconds (User)

Phase Timing Summary

Phase	A	B	C
Phase Change Time (sec)	35	0	22
Green Time (sec)	9	16	7
Phase Time (sec)	15	22	13
Phase Split	30%	44%	26%
Phase Frequency (%)	100.0	100.0	100.0

See the Timing Analysis report for more detailed information including input values of Yellow Time and All-Red Time, and information on any adjustments to Intergreen Time, Phase Time and Green Time values in cases of Pedestrian Actuation, Minor Phase Actuation and Phase Frequency values (user-specified or implied) less than 100%.

Output Phase Sequence

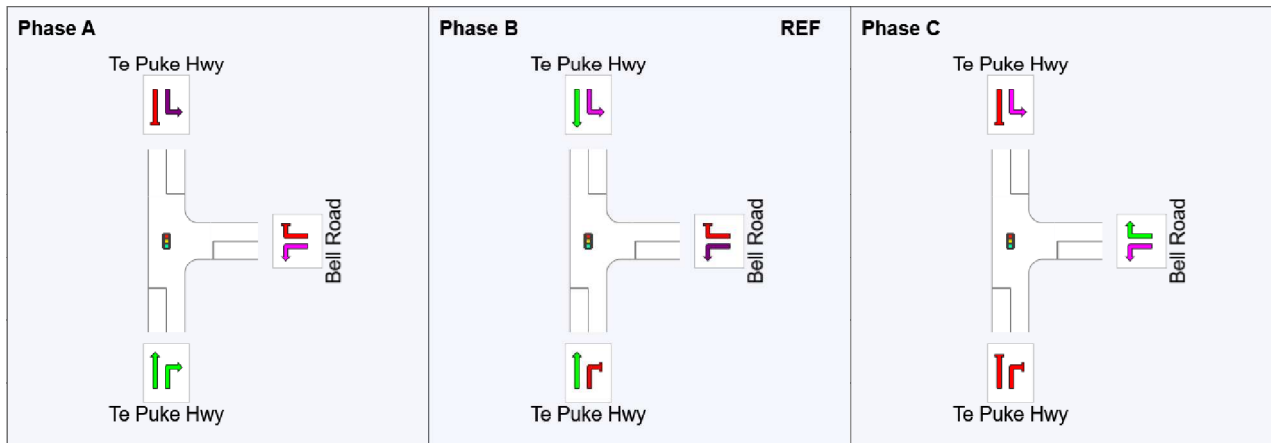

REF: Reference Phase

VAR: Variable Phase

	Normal Movement		Permitted/Opposed
	Slip/Bypass-Lane Movement		Opposed Slip/Bypass-Lane
	Stopped Movement		Turn On Red
	Other Movement Class (MC) Running		Undetected Movement
	Mixed Running & Stopped MCs		Continuous Movement
	Other Movement Class (MC) Stopped		Phase Transition Applied

SIGNAL OFFSETS

Network: N101 [2063_Opt10D_AM (Network Folder: General)]

Output produced by SIDRA INTERSECTION Version: 9.1.6.228

New Network

Network Category: (None)

Network Cycle Time = 120 seconds (Network Optimum Cycle Time - Minimum Delay)

SIGNAL OFFSETS

Offset Definition: Green Start

Reference Site / CCG: CCG1 [CCG_1]¹

Site ID	2440a ¹	2439a ¹	2514a	2860a	2859a
CCG ID (if applicable)	CCG1	CCG1	NA	NA	NA
Offset (sec)	0	0	77	89	37
Program / User	P	P	P	P	P
Reference Phase	A	A	A	A	A
Route ID	R101	R101	R101	R101	R101

¹ Reference Site / CCG as specified in the Network Timing dialog, Network Timing Data tab. This Site / CCG is included in the Route with the highest Offset Priority and is used in offset calculations.

ROUTE OFFSET RESULTS

Route ID: R101

Route Name: Sands NB

Offset Priority: 1

Offset Method: Start of Green (Leading)

Movement Class for Offset Calculation: Light Vehicles

Site ID	2440a ¹	2439a ¹	2514a	2860a	2859a
Reference Phase	A	A	A	A	A
Offset (sec)	0	0	77	89	37
Calculated offset used (Yes / No)	Yes	Yes	Yes	Yes	Yes
Approach	S	S	S	S	S
Turn	T1	T1	T1	T1	T1
Stopline Travel Distance (m)	370.4	129.6	267.7	156.5	161.7
Stopline Travel Time (sec)	28	11	21	12	13
Start Phase of Movement	B	C	A	A	D1
Relative Offset - Phase (sec)	0	39	21	12	15
Relative Offset - Movement (sec)	0	0	21	12	15
Phase Change Time (sec)	33	56	77	89	104
Displayed Green Start Time (sec)	39	62	83	95	110
Displayed Green Time (sec)	51	58	28	75	17
Effective Green Start Time (sec)	42	65	86	98	113
Effective Green Time (sec)	51	58	28	75	17
Green Time Ratio	0.425	0.483	0.233	0.625	0.142
% Arriving During Green	42.5	71.0	36.9	98.0	53.3
Platoon Ratio	1.000	1.470	1.581	1.568	3.760
Equivalent AT	3	4	5	5	6
Average Delay (sec)	187.9	14.9	66.1	0.5	26.8
% Back of Queue - Distance (m)	343.5	115.0	136.9	2.9	8.0
% Back of Queue - Vehicles	44.5	15.0	17.9	0.4	1.1
Effective Stop Rate	1.88	0.64	1.13	0.03	0.42
Proportion Queued	1.00	0.70	1.00	0.03	0.55

Route ID: R102

Route Name: Sands SB

Offset Priority: 2

Offset Method: Start of Green (Leading)

Movement Class for Offset Calculation: Light Vehicles

Site ID	2859a	2860a	2514a	2439a ¹	2440a ¹
Reference Phase	A	A	A	A	A
Offset (sec)	37	89	77	0	0
Calculated offset used (Yes / No)	No	No	No	No	No

Approach	N	N	N	N	N
Turn	T1	T1	T1	T1	T1
Stoptline Travel Distance (m)	0.0	169.9	149.4	274.6	129.1
Stoptline Travel Time (sec)	0	15	12	22	10
Start Phase of Movement	E	A	A	D	A
Relative Offset - Phase (sec)	0	94	108	13	13
Relative Offset - Movement (sec)	0	94	108	13	13
Phase Change Time (sec)	115	89	77	90	0
Displayed Green Start Time (sec)	1	95	83	96	6
Displayed Green Time (sec)	6	75	28	57	50
Effective Green Start Time (sec)	4	98	86	99	9
Effective Green Time (sec)	6	75	28	57	50
Green Time Ratio	0.050	0.625	0.233	0.475	0.417
% Arriving During Green	5.0	75.1	9.5	71.2	64.2
Platoon Ratio	1.000	1.201	0.409	1.499	1.541
Equivalent AT	3	4	1	4	5
Average Delay (sec)	67.2	45.3	225.8	66.5	18.4
% Back of Queue - Distance (m)	6.5	145.0	132.0	191.5	108.0
% Back of Queue - Vehicles	0.9	19.3	17.2	24.9	14.0
Effective Stop Rate	0.73	1.07	1.81	1.21	0.67
Proportion Queued	1.00	0.92	1.00	0.90	0.74

- 1 Reference Site / CCG as specified in the Network Timing dialog, Network Timing Data tab. This Site / CCG is included in the Route with the highest Offset Priority and is used in offset calculations.

SIDRA INTERSECTION 9.1 | Copyright © 2000-2024 Akcelik and Associates Pty Ltd | sidrasolutions.com

Organisation: AJW | Licence: NETWORK / 1PC | Processed: Friday, 27 March 2026 7:45:56 pm

Project: C:\Users\annaj\OneDrive\AW Consulting\Projects\Boffa Miskell Jobs\Wairakei South\ITA Work Feb 2026\Final SIDRA Modelling\Third Round Base Sidra File\2063_TTHM 10D Mitigated.sip9

SITE LAYOUT

Site: 2122a [2122 TEL Te Puke Highway AM (Site Folder: General)]

New Site
Site Category: (None)
Roundabout

Layout pictures are schematic functional drawings reflecting input data. They are not design drawings.

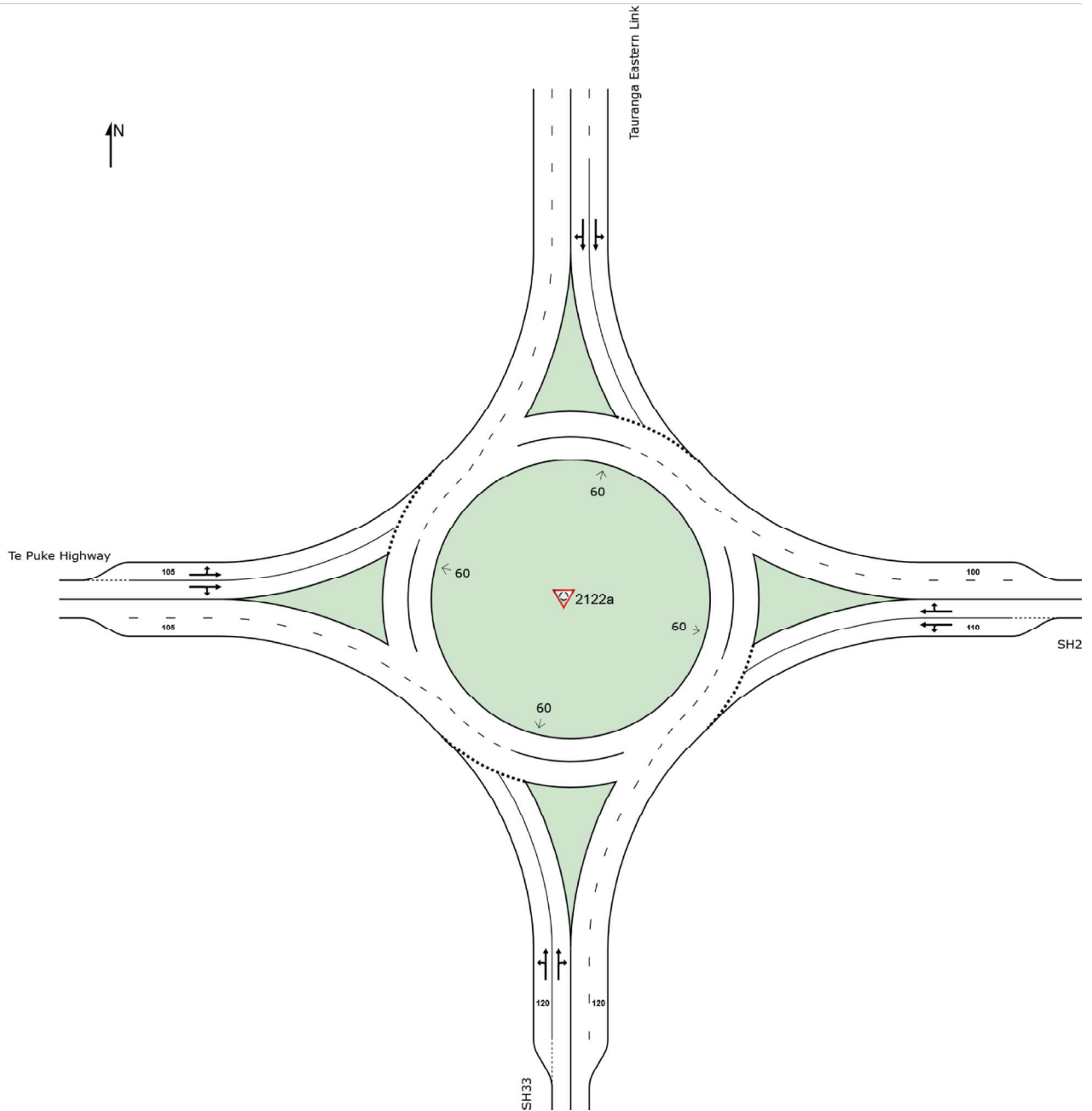

SIDRA INTERSECTION 9.1 | Copyright © 2000-2024 Kcelik and Associates Pty Ltd | sidrasolutions.com

Organisation: AJW | Licence: NETWORK / 1PC | Created: Friday, 27 March 2026 7:57:20 pm

Project: C:\Users\anna\OneDrive\AW Consulting\Projects\Boffa Miskell Jobs\Wairakei South\ITA Work Feb 2026\Final SIDRA Modelling\Third Round Base Sidra File\2063_TTHM 10D Mitigated.sip9

MOVEMENT SUMMARY

 Site: 2122a [2122 TEL Te Puke Highway AM (Site Folder: General)]

Output produced by SIDRA INTERSECTION Version: 9.1.6.228

New Site
 Site Category: (None)
 Roundabout

Vehicle Movement Performance															
Mov ID	Turn	Mov Class	Demand Flows		Arrival Flows		Deg. Satn	Aver. Delay	Level of Service	95% Back Of Queue	Prop. Que	Eff. Stop Rate	Aver. No. of Cycles	Aver. Speed	
			[Total HV]	%	[Total HV]	%	v/c	sec		[Veh. veh	Dist] m			km/h	
South: SH33															
1	L2	All MCs	133	18.3	133	18.3	0.539	8.9	LOS A	4.6	37.2	0.95	0.91	1.17	49.6
2	T1	All MCs	489	19.8	489	19.8	0.539	9.3	LOS A	4.6	37.2	0.94	0.93	1.17	44.5
3	R2	All MCs	1	0.0	1	0.0	0.539	17.9	LOS B	3.8	31.4	0.92	0.94	1.17	43.7
Approach			623	19.4	623	19.4	0.539	9.3	LOS A	4.6	37.2	0.94	0.92	1.17	48.5
East: SH2															
4	L2	All MCs	1	0.0	1	0.0	0.261	7.1	LOS A	1.5	12.2	0.84	0.74	0.84	45.9
5	T1	All MCs	138	16.0	138	16.0	0.261	6.4	LOS A	1.5	12.2	0.84	0.74	0.84	49.7
6	R2	All MCs	707	15.2	707	15.2	0.970	41.2	LOS D	22.3	176.3	1.00	1.83	2.81	33.0
Approach			846	15.3	846	15.3	0.970	35.5	LOS D	22.3	176.3	0.97	1.65	2.49	43.7
North: Tauranga Eastern Link															
7	L2	All MCs	939	8.1	939	8.1	0.796	5.1	LOS A	10.0	75.4	0.84	0.77	1.03	46.3
8	T1	All MCs	574	17.6	574	17.6	0.796	6.1	LOS A	10.0	77.1	0.88	0.85	1.13	45.0
9	R2	All MCs	285	17.3	285	17.3	0.796	13.1	LOS B	9.6	77.1	0.89	0.86	1.14	49.5
Approach			1798	12.6	1798	12.6	0.796	6.7	LOS A	10.0	77.1	0.86	0.81	1.08	48.5
West: Te Puke Highway															
10	L2	All MCs	61	43.1	61	43.1	0.348	9.0	LOS A	1.9	16.4	0.85	0.81	0.90	49.7
11	T1	All MCs	183	12.6	183	12.6	0.381	6.8	LOS A	2.6	20.6	0.86	0.80	0.91	49.6
12	R2	All MCs	197	15.5	197	15.5	0.381	12.2	LOS B	2.6	20.6	0.89	0.78	0.92	49.5
Approach			441	18.1	441	18.1	0.381	9.5	LOS A	2.6	20.6	0.87	0.79	0.92	49.6
All Vehicles			3708	15.0	3708	15.0	0.970	14.0	LOS B	22.3	176.3	0.90	1.02	1.39	48.0

Site Level of Service (LOS) Method: Delay (SIDRA). Site LOS Method is specified in the Parameter Settings dialog (Options tab).
 Roundabout LOS Method: SIDRA Roundabout LOS.
 Vehicle movement LOS values are based on average delay per movement.
 Intersection and Approach LOS values are based on average delay for all vehicle movements.
 Roundabout Capacity Model: SIDRA Standard.
 Delay Model: SIDRA Standard (Control Delay: Geometric Delay is included).
 Queue Model: SIDRA queue estimation methods are used for Back of Queue and Queue at Start of Gap.
 Gap-Acceptance Capacity Formula: SIDRA Standard (Akçelik M3D).
 HV (%) values are calculated for All Movement Classes of All Heavy Vehicle Model Designation.
 Arrival Flows used in performance calculations are adjusted to include any Initial Queued Demand and Upstream Capacity Constraint effects.

SITE LAYOUT

Site: 1335 [1335 Tara Rd Parton Rd RAB AM (Site Folder: General)]

New Site
Site Category: (None)
Roundabout

Layout pictures are schematic functional drawings reflecting input data. They are not design drawings.

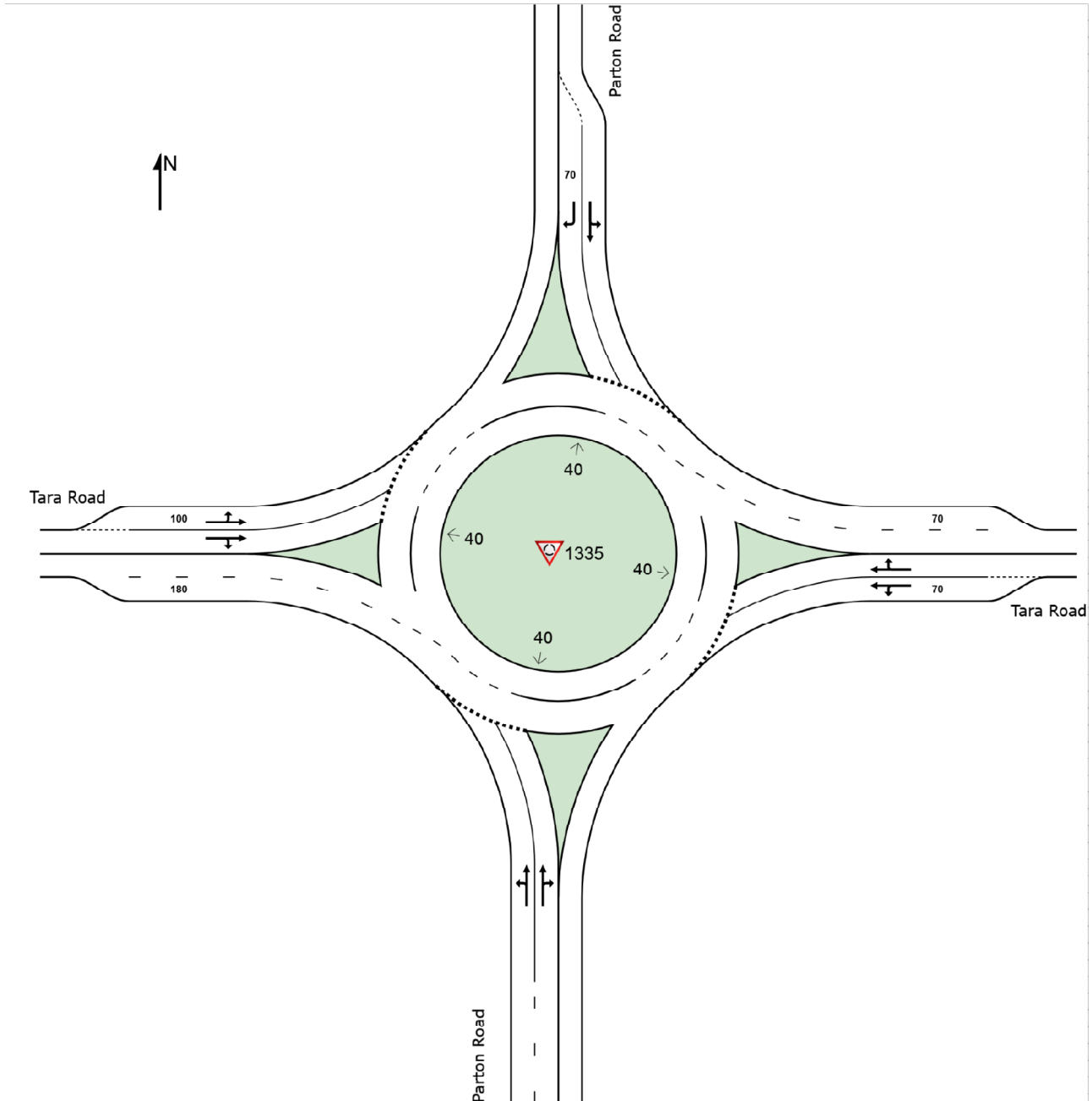

SIDRA INTERSECTION 9.1 | Copyright © 2000-2024 Akcelik and Associates Pty Ltd | sidrasolutions.com

Organisation: AJW | Licence: NETWORK / 1PC | Created: Friday, 27 March 2026 7:57:28 pm

Project: C:\Users\annaj\OneDrive\AW Consulting\Projects\Boffa Miskell Jobs\Wairakei South\ITA Work Feb 2026\Final SIDRA Modelling\Third Round Base Sidra File\2063_TTHM 10D Mitigated.sip9

MOVEMENT SUMMARY

 Site: 1335 [1335 Tara Rd Parton Rd RAB AM (Site Folder: General)]

Output produced by SIDRA INTERSECTION Version: 9.1.6.228

New Site
 Site Category: (None)
 Roundabout

Vehicle Movement Performance															
Mov ID	Turn	Mov Class	Demand Flows		Arrival Flows		Deg. Satn	Aver. Delay	Level of Service	95% Back Of Queue	Dist	Prop. Que	Eff. Stop Rate	Aver. No. of Cycles	Aver. Speed
			[Total HV]	%	[Total HV]	%	v/c	sec		[Veh. veh	m				km/h
South: Parton Road															
1	L2	All MCs	97	4.8	97	4.8	0.128	5.3	LOS A	0.6	4.0	0.62	0.65	0.62	49.9
2	T1	All MCs	37	4.8	37	4.8	0.141	3.4	LOS A	0.7	4.8	0.61	0.66	0.61	44.9
3	R2	All MCs	103	4.8	103	4.8	0.141	9.7	LOS A	0.7	4.8	0.61	0.66	0.61	44.4
Approach			237	4.8	237	4.8	0.141	6.9	LOS A	0.7	4.8	0.62	0.66	0.62	46.5
East: Tara Road															
4	L2	All MCs	162	4.8	162	4.8	0.390	3.1	LOS A	2.0	14.8	0.47	0.34	0.47	46.9
5	T1	All MCs	761	4.8	761	4.8	0.390	2.7	LOS A	2.0	14.8	0.48	0.33	0.48	50.5
6	R2	All MCs	7	4.8	7	4.8	0.390	8.9	LOS A	2.0	14.5	0.49	0.33	0.49	46.4
Approach			931	4.8	931	4.8	0.390	2.9	LOS A	2.0	14.8	0.48	0.33	0.48	49.8
North: Parton Road															
7	L2	All MCs	12	4.8	12	4.8	0.096	4.5	LOS A	0.4	3.0	0.53	0.45	0.53	46.7
8	T1	All MCs	69	4.8	69	4.8	0.096	3.6	LOS A	0.4	3.0	0.53	0.45	0.53	46.9
9	R2	All MCs	174	4.8	174	4.8	0.155	9.4	LOS A	0.7	5.3	0.53	0.67	0.53	46.4
Approach			255	4.8	255	4.8	0.155	7.6	LOS A	0.7	5.3	0.53	0.60	0.53	46.5
West: Tara Road															
10	L2	All MCs	115	4.8	115	4.8	0.185	3.9	LOS A	0.9	6.7	0.32	0.40	0.32	50.7
11	T1	All MCs	431	4.8	431	4.8	0.304	3.5	LOS A	1.8	12.9	0.33	0.41	0.33	50.3
12	R2	All MCs	102	4.8	102	4.8	0.304	10.0	LOS A	1.8	12.9	0.33	0.42	0.33	49.5
Approach			647	4.8	647	4.8	0.304	4.6	LOS A	1.8	12.9	0.33	0.41	0.33	50.3
All Vehicles			2069	4.8	2069	4.8	0.390	4.4	LOS A	2.0	14.8	0.46	0.43	0.46	49.1

Site Level of Service (LOS) Method: Delay (SIDRA). Site LOS Method is specified in the Parameter Settings dialog (Options tab).
 Roundabout LOS Method: SIDRA Roundabout LOS.
 Vehicle movement LOS values are based on average delay per movement.
 Intersection and Approach LOS values are based on average delay for all vehicle movements.
 Roundabout Capacity Model: SIDRA Standard.
 Delay Model: SIDRA Standard (Control Delay: Geometric Delay is included).
 Queue Model: SIDRA queue estimation methods are used for Back of Queue and Queue at Start of Gap.
 Gap-Acceptance Capacity Formula: SIDRA Standard (Akçelik M3D).
 HV (%) values are calculated for All Movement Classes of All Heavy Vehicle Model Designation.
 Arrival Flows used in performance calculations are adjusted to include any Initial Queued Demand and Upstream Capacity Constraint effects.

SIDRA Network and Intersection Outputs

2063 10D Mitigated PM

NETWORK LAYOUT

Network: N101 [2063_Opt10D_PM (Network Folder: General)]

New Network
 Network Category: (None)

Layout pictures are schematic functional drawings reflecting input data. They are not design drawings.

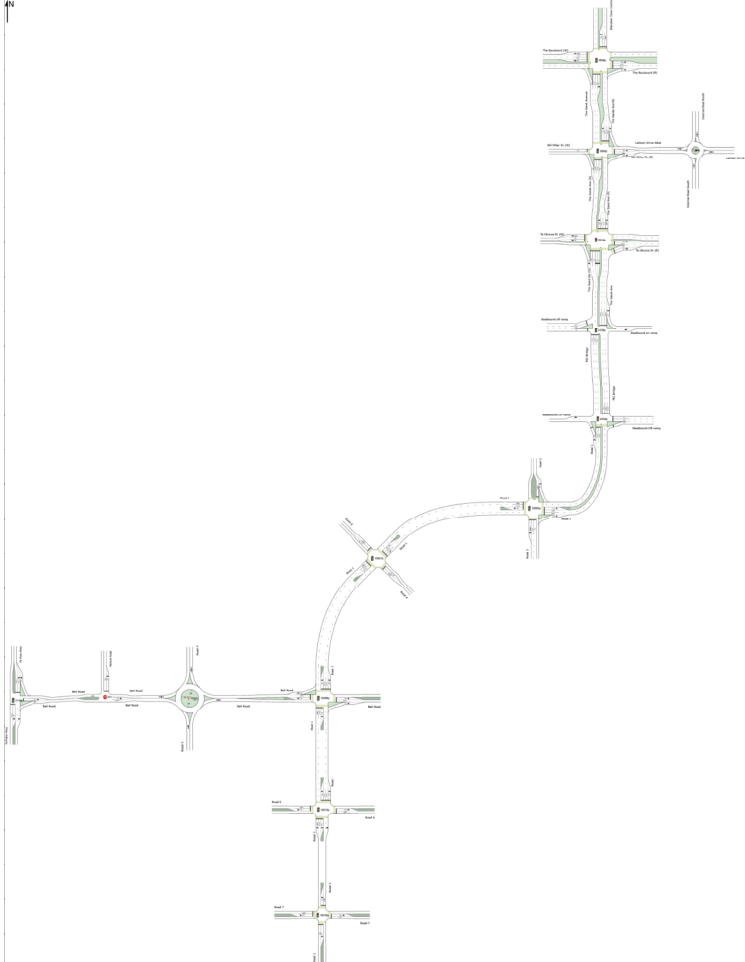

SITES IN NETWORK		
Site ID	CCG ID	Site Name
2859p	NA	2859 Boulv_TheSand_PM
2860p	NA	2860 The Sand_Bill Miller_PM
2514p	NA	2514 Sands_Te Okuroa_PM
2439p	CCG1	2439 Papamoia Eastern Int North_PM
2440p	CCG1	2440 Papamoia Eastern Int South_PM
10003p	NA	10003_PM
10007p	NA	10007_PM
10008p	NA	10008_PM
10015p	NA	10015_PM
10016p	NA	10016_PM
10013p	NA	10013_PM
101	NA	1348 Bell Rd Parton Rd PM
2140p	NA	2140 Te Puke Hwy Bell Rd PM Signals
99p	NA	MIBA Internal Roundabout PM

APPROACH LEVEL OF SERVICE

Approach Level of Service

Network: N101 [2063_Opt10D_PM (Network Folder: General)]

Output produced by SIDRA INTERSECTION Version: 9.1.6.228

New Network

Network Category: (None)

Network Cycle Time = 100 seconds (Network Optimum Cycle Time - Minimum Delay)

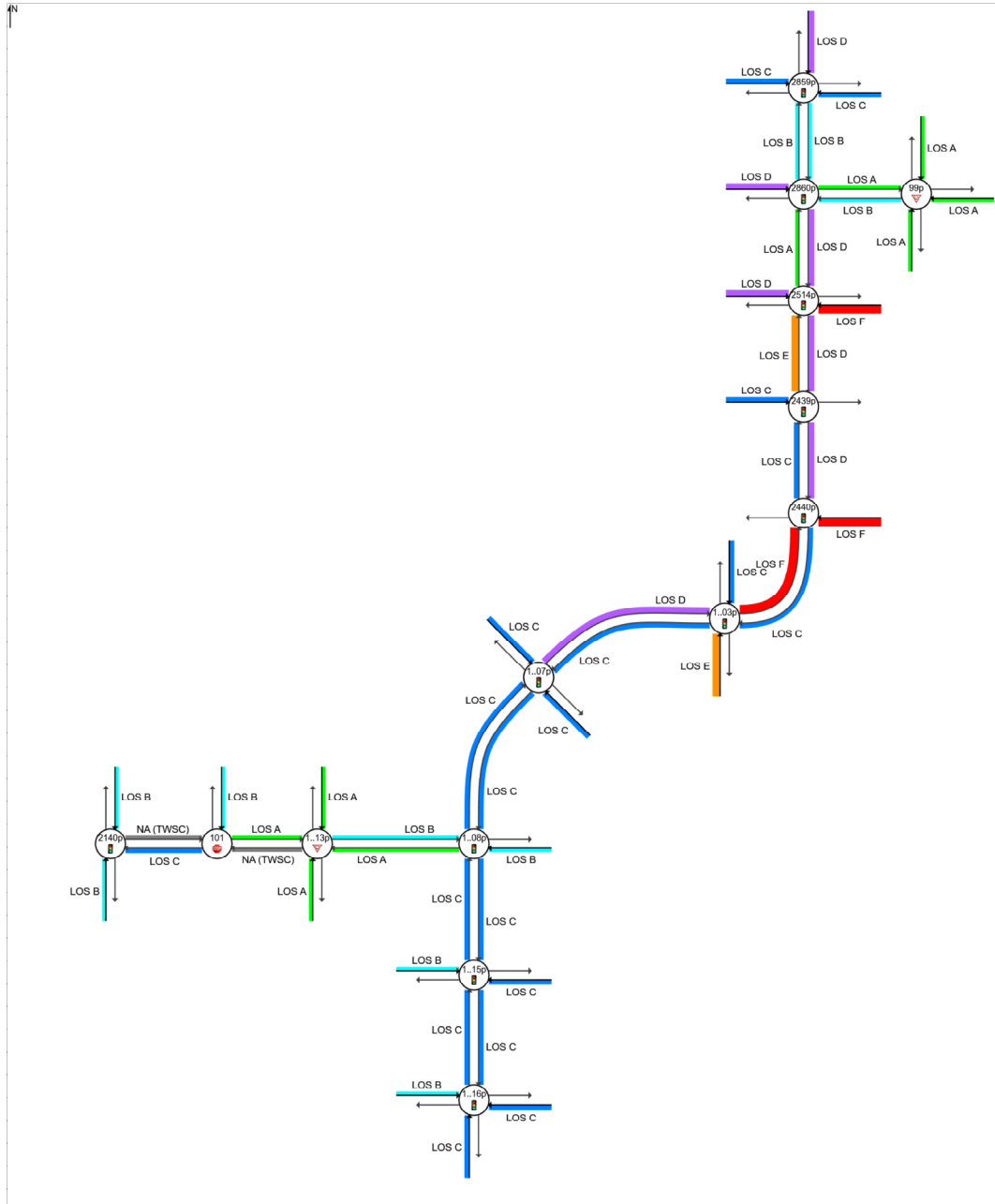

Colour code based on Level of Service

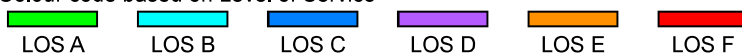

NA (TWSC): Level of Service is not defined for major road approaches or the intersection as a whole for Two-Way Sign Control (HCM LOS rule).

Site Level of Service (LOS) Method: Delay (SIDRA). Site LOS Method is specified in the Network Data dialog (Override Site Data tab).

Delay Model: SIDRA Standard (Control Delay: Geometric Delay is included).

DEGREE OF SATURATION

Ratio of Arrival Flow to Capacity, v/c ratio per lane

Network: N101 [2063_Opt10D_PM (Network Folder: General)]

Output produced by SIDRA INTERSECTION Version: 9.1.6.228

New Network

Network Category: (None)

Network Cycle Time = 100 seconds (Network Optimum Cycle Time - Minimum Delay)

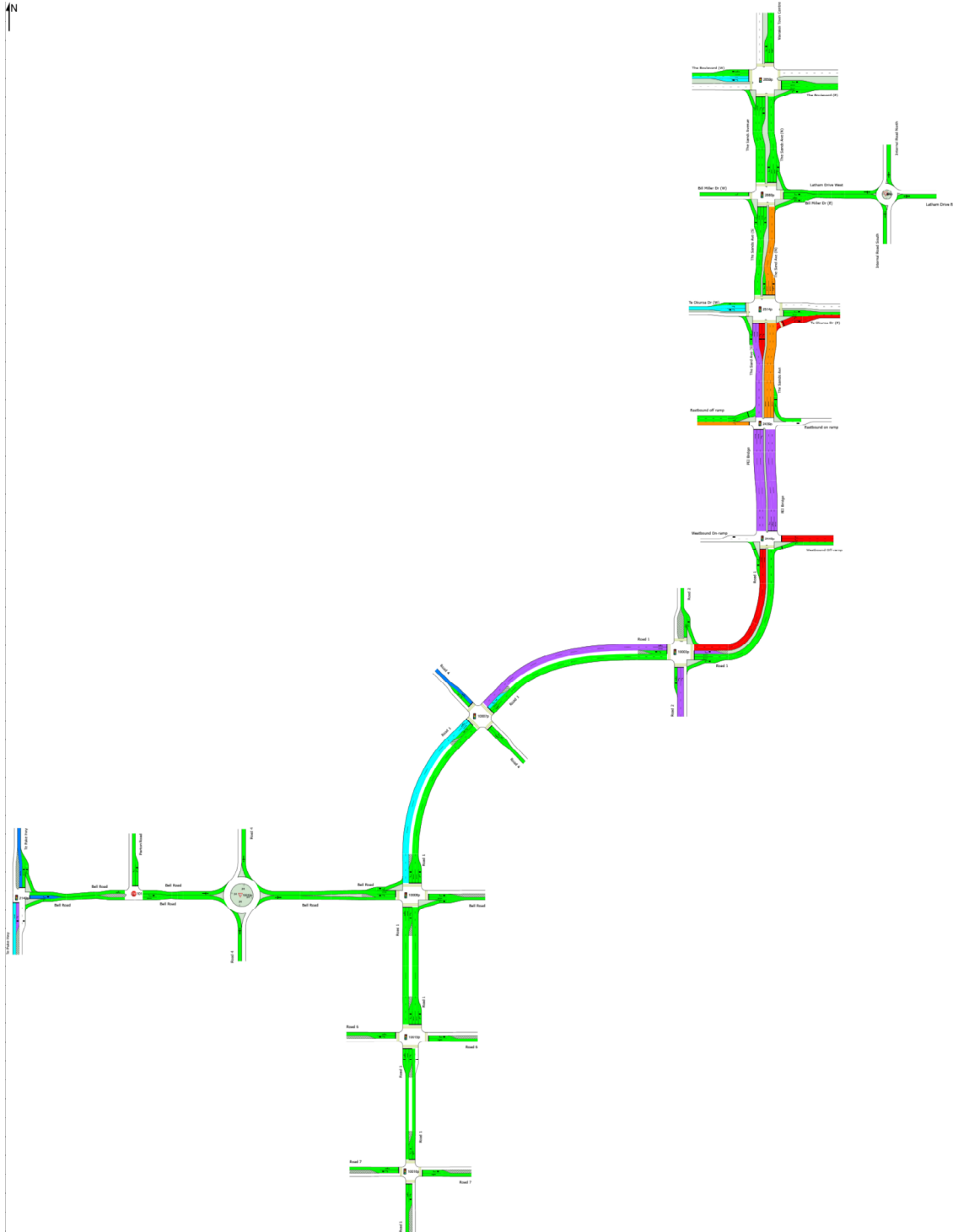

Colour code based on Degree of Saturation

[< 0.6] [0.6 - 0.7] [0.7 - 0.8] [0.8 - 0.9] [0.9 - 1.0] [> 1.0]

QUEUE STORAGE RATIO (PERCENTILE)

Ratio of the 95% Back of Queue Distance to the available queue storage distance per lane

Network: N101 [2063_Opt10D_PM (Network Folder: General)]

Output produced by SIDRA INTERSECTION Version: 9.1.6.228

New Network

Network Category: (None)

Network Cycle Time = 100 seconds (Network Optimum Cycle Time - Minimum Delay)

Short Lanes are not included in determining Queue Storage Ratios.

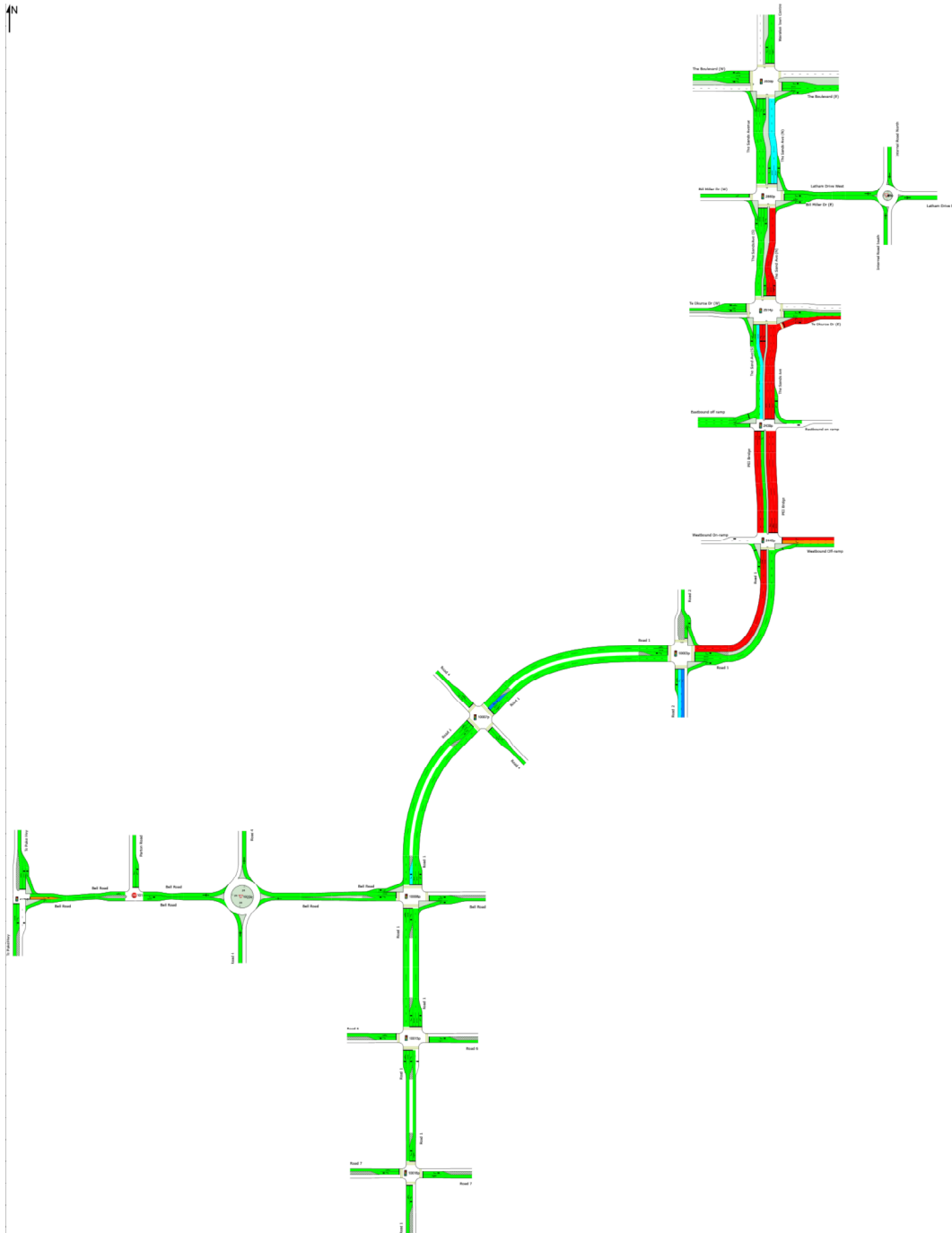

Colour code based on Queue Storage Ratio

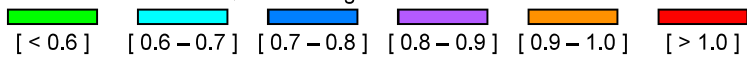

Queue Model: SIDRA queue estimation methods are used for Back of Queue and Queue at Start of Green.

CCG MOVEMENT SUMMARY

Common Control Group: CCG1 [CCG_PM1]

Output produced by SIDRA INTERSECTION Version: 9.1.6.228

Network: N101
[2063_Opt10D_PM (Network Folder: General)]

EQUISAT (Fixed-Time/SCATS) Coordinated Cycle Time = 100 seconds (Network Optimum Cycle Time - Minimum Delay)

Vehicle Movement Performance (CCG)															
Mov ID	Turn	Mov Class	Demand Flows		Arrival Flows		Deg. Satn	Aver. Delay	Level of Service	Aver. Back Of Queue		Prop. Que	Eff. Stop Rate	Aver. No. of Cycles	Aver. Speed
			[Total HV]	%	[Total HV]	%				[Veh. veh	Dist]				
Site: 2439p [2439 Papamoa Eastern Int North_PM]															
South: PEI Bridge															
2	T1	All MCs	1707	7.7	1153	8.0	0.810	19.5	LOS B	14.3	107.2	0.82	0.76	0.86	16.1
3	R2	All MCs	165	7.7	112	8.0	0.898	66.1	LOS E	3.8	28.3	1.00	0.96	1.31	20.2
Approach			1873	7.7	1264	8.0	0.898	23.7	LOS C	14.3	107.2	0.84	0.78	0.90	17.2
North: The Sands Ave															
7	L2	All MCs	760	7.7	687	7.7	0.386	4.5	LOS A	0.0	0.0	0.00	0.46	0.00	45.2
8	T1	All MCs	1891	7.7	1710	7.7	0.964	48.5	LOS D	23.7	177.2	0.96	1.20	1.35	14.1
Approach			2651	7.7	2397	7.7	0.964	35.9	LOS D	23.7	177.2	0.68	0.99	0.96	22.5
West: Eastbound off ramp															
10	L2	All MCs	794	7.7	794	7.7	0.446	21.8	LOS C	7.6	56.6	0.69	0.76	0.69	31.7
12	R2	All MCs	101	7.7	101	7.7	0.947	81.3	LOS F	4.1	30.9	1.00	1.17	1.75	15.7
Approach			895	7.7	895	7.7	0.947	28.5	LOS C	7.6	56.6	0.72	0.80	0.81	28.5
All Vehicles			5418	7.7	4556	9.2	0.964	31.0	LOS C	23.7	177.2	0.73	0.89	0.91	22.9
Site: 2440p [2440 Papamoa Eastern Int South_PM]															
South: Road 1															
1	L2	All MCs	284	7.0	284	7.0	0.287	17.1	LOS B	4.4	32.7	0.56	0.70	0.56	38.7
2	T1	All MCs	849	7.0	849	7.0	* 1.513	512.9	LOS F	47.2	350.0	1.00	2.97	4.15	2.4
Approach			1134	7.0	1134	7.0	1.513	388.6	LOS F	47.2	350.0	0.89	2.40	3.25	4.2
East: Westbound Off-ramp															
4	L2	All MCs	366	7.0	366	7.0	0.545	30.7	LOS C	8.6	63.7	0.84	0.81	0.84	27.6
6	R2	All MCs	1018	7.0	1018	7.0	* 1.473	480.0	LOS F	67.1	497.5	1.00	2.37	3.98	3.6
Approach			1384	7.0	1384	7.0	1.473	361.1	LOS F	67.1	497.5	0.96	1.96	3.15	4.7
North: PEI Bridge															
8	T1	All MCs	876	7.0	797	7.0	0.855	19.9	LOS B	15.5	115.0	0.85	0.83	0.92	15.9
9	R2	All MCs	1116	7.0	1016	7.0	* 0.897	47.3	LOS D	15.5	115.0	0.99	0.99	1.19	24.2
Approach			1992	7.0	1813	7.0	0.897	35.2	LOS D	15.5	115.0	0.93	0.92	1.07	22.6
All Vehicles			4509	7.0	4331	7.3	1.513	231.9	LOS F	67.1	497.5	0.93	1.64	2.31	6.3

Site Level of Service (LOS) Method: Delay (SIDRA). Site LOS Method is specified in the Network Data dialog (Override Site Data tab).

Vehicle movement LOS values are based on average delay per movement.

Intersection and Approach LOS values are based on average delay for all vehicle movements.

Delay Model: SIDRA Standard (Control Delay: Geometric Delay is included).

Gap-Acceptance Capacity Formula: SIDRA Standard (Akçelik M3D).

HV (%) values are calculated for All Movement Classes of All Heavy Vehicle Model Designation.

Arrival Flows used in performance calculations are adjusted to include any Initial Queued Demand and Upstream Capacity Constraint effects.

* Critical Movement (Signal Timing)

MOVEMENT SUMMARY

Site: 2859p [2859 Boulv_TheSand_PM (Site Folder: General)]

Output produced by SIDRA INTERSECTION Version: 9.1.6.228

Network: N101
[2063_Opt10D_PM (Network Folder: General)]

Site Category: (None)

Signals - EQUISAT (Fixed-Time/SCATS) Coordinated Cycle Time = 100 seconds (Network Optimum Cycle Time - Minimum Delay)

Vehicle Movement Performance													
Mov ID	Turn	Mov Class	Demand Flows [Total HV]	Arrival Flows [Total HV]	Deg. Satn	Aver. Delay	Level of Service	Aver. Back Of Queue	Prop. Que	Eff. Stop Rate	Aver. No. of Cycles	Aver. Speed	
			veh/h %	veh/h %	v/c	sec		[Veh. veh]				km/h	
								Dist]					
								m					
South: The Sands Avenue													
1	L2	All MCs	868 3.3	713 3.3	0.489	6.0	LOS A	4.1	29.4	0.31	0.61	0.31	40.6
2	T1	All MCs	248 3.3	204 3.3	*0.382	10.2	LOS B	2.1	15.4	0.37	0.31	0.37	41.3
3	R2	All MCs	381 3.3	313 3.3	0.308	21.6	LOS C	2.4	17.1	0.53	0.66	0.53	29.9
Approach			1498 3.3	1230 3.3	0.489	10.6	LOS B	4.1	29.4	0.38	0.57	0.38	37.5
East: The Boulevard (E)													
4	L2	All MCs	173 3.3	173 3.3	0.117	6.6	LOS A	1.1	7.6	0.22	0.57	0.22	39.0
5	T1	All MCs	316 3.3	316 3.3	*0.394	37.2	LOS D	4.1	29.7	0.91	0.74	0.91	27.2
6	R2	All MCs	38 3.3	38 3.3	*0.348	56.7	LOS E	1.2	8.4	0.99	0.73	0.99	25.2
Approach			526 3.3	526 3.3	0.394	28.6	LOS C	4.1	29.7	0.69	0.68	0.69	28.7
North: Wairakei Town Centre													
7	L2	All MCs	16 3.3	16 3.3	0.491	57.3	LOS E	1.7	12.4	1.00	0.75	1.00	25.7
8	T1	All MCs	96 3.3	96 3.3	0.491	52.7	LOS D	1.8	12.6	1.00	0.75	1.00	20.8
9	R2	All MCs	60 3.3	60 3.3	*0.551	57.8	LOS E	1.9	13.6	1.00	0.77	1.04	24.9
Approach			172 3.3	172 3.3	0.551	54.9	LOS D	1.9	13.6	1.00	0.76	1.01	22.9
West: The Boulevard (W)													
10	L2	All MCs	49 3.3	49 3.3	0.196	28.2	LOS C	2.7	19.4	0.73	0.65	0.73	34.1
11	T1	All MCs	217 3.3	217 3.3	0.196	23.6	LOS C	2.8	19.8	0.73	0.61	0.73	32.3
12	R2	All MCs	438 3.3	438 3.3	*0.603	27.0	LOS C	4.0	29.0	0.96	0.81	0.96	22.8
Approach			704 3.3	704 3.3	0.603	26.1	LOS C	4.0	29.0	0.87	0.74	0.87	27.4
All Vehicles			2900 3.3	2632 3.6	0.603	21.2	LOS C	4.1	29.7	0.61	0.65	0.61	31.1

Site Level of Service (LOS) Method: Delay (SIDRA). Site LOS Method is specified in the Network Data dialog (Override Site Data tab).

Vehicle movement LOS values are based on average delay per movement.

Intersection and Approach LOS values are based on average delay for all vehicle movements.

Delay Model: SIDRA Standard (Control Delay: Geometric Delay is included).

Queue Model: SIDRA queue estimation methods are used for Back of Queue and Queue at Start of Green.

Gap-Acceptance Capacity Formula: SIDRA Standard (Akçelik M3D).

HV (%) values are calculated for All Movement Classes of All Heavy Vehicle Model Designation.

Arrival Flows used in performance calculations are adjusted to include any Initial Queued Demand and Upstream Capacity Constraint effects.

* Critical Movement (Signal Timing)

Pedestrian Movement Performance											
Mov ID	Crossing	Dem. Flow	Aver. Delay	Level of Service	AVERAGE BACK OF QUEUE		Prop. Que	Eff. Stop Rate	Travel Time	Travel Dist.	Aver. Speed
		ped/h	sec		[Ped ped]	Dist]			sec	m	m/sec
						m					

South: The Sands Avenue											
P1 Full	32	44.2	LOS E	0.1	0.1	0.94	0.94	59.6	20.0	0.34	
East: The Boulevard (E)											
P21 Stage 1	32	28.4	LOS C	0.1	0.1	0.88	0.88	43.8	20.0	0.46	
P22 Stage 2	32	44.2	LOS E	0.1	0.1	0.94	0.94	59.6	20.0	0.34	
North: Wairakei Town Centre											
P3 Full	32	44.2	LOS E	0.1	0.1	0.94	0.94	59.6	20.0	0.34	
West: The Boulevard (W)											
P4 Full	32	44.2	LOS E	0.1	0.1	0.94	0.94	59.6	20.0	0.34	
All Pedestrians	158	41.1	LOS E	0.1	0.1	0.93	0.93	56.5	20.0	0.35	

Level of Service (LOS) Method: SIDRA Pedestrian LOS Method (Based on Average Delay)

Pedestrian movement LOS values are based on average delay per pedestrian movement.

Intersection LOS value for Pedestrians is based on average delay for all pedestrian movements.

SIDRA INTERSECTION 9.1 | Copyright © 2000-2024 Kcelik and Associates Pty Ltd | sidrasolutions.com

Organisation: AJW | Licence: NETWORK / 1PC | Processed: Friday, 27 March 2026 7:50:12 pm

Project: C:\Users\annaj\OneDrive\AW Consulting\Projects\Boffa Miskell Jobs\Wairakei South\ITA Work Feb 2026\Final SIDRA Modelling\Third Round Base Sidra File\2063_TTHM 10D Mitigated.sip9

MOVEMENT SUMMARY

Site: 2860p [2860 The Sand_Bill Miller_PM (Site Folder: General)]

Output produced by SIDRA INTERSECTION Version: 9.1.6.228

Network: N101
[2063_Opt10D_PM (Network Folder: General)]

Site Category: (None)

Signals - EQUISAT (Fixed-Time/SCATS) Coordinated Cycle Time = 100 seconds (Network Optimum Cycle Time - Minimum Delay)

Vehicle Movement Performance													
Mov ID	Turn	Mov Class	Demand Flows [Total HV]	Arrival Flows [Total HV]	Deg. Satn	Aver. Delay	Level of Service	Aver. Back Of Queue	Prop. Que	Eff. Stop Rate	Aver. No. of Cycles	Aver. Speed	
			veh/h %	veh/h %	v/c	sec		[Veh. veh]	[Dist] m			km/h	
South: The Sands Ave (S)													
1	L2	All MCs	19 3.9	15 3.9	0.010	4.6	LOS A	0.0	0.1	0.03	0.50	0.03	44.2
2	T1	All MCs	1421 3.9	1152 3.9	*0.531	2.8	LOS A	4.3	30.8	0.22	0.19	0.22	39.6
3	R2	All MCs	41 3.9	33 3.9	*0.307	58.8	LOS E	1.1	7.6	1.00	0.74	1.00	7.8
Approach			1481 3.9	1200 3.9	0.531	4.4	LOS A	4.3	30.8	0.24	0.21	0.24	35.9
East: Bill Miller Dr (E)													
4	L2	All MCs	232 3.9	232 3.9	0.303	9.3	LOS A	2.5	18.3	0.45	0.66	0.45	22.2
5	T1	All MCs	6 3.9	6 3.9	0.120	41.4	LOS D	0.8	5.9	0.91	0.70	0.91	24.6
6	R2	All MCs	55 3.9	55 3.9	0.120	45.9	LOS D	0.8	5.9	0.91	0.71	0.91	7.0
Approach			293 3.9	293 3.9	0.303	16.8	LOS B	2.5	18.3	0.54	0.67	0.54	16.4
North: The Sands Ave (N)													
7	L2	All MCs	133 3.9	133 3.9	0.084	4.8	LOS A	0.2	1.3	0.08	0.52	0.08	35.7
8	T1	All MCs	860 3.9	860 3.9	0.458	16.3	LOS B	8.6	62.3	0.72	0.58	0.72	20.8
9	R2	All MCs	14 3.9	14 3.9	0.126	57.5	LOS E	0.4	3.1	1.00	0.69	1.00	22.3
Approach			1006 3.9	1006 3.9	0.458	15.3	LOS B	8.6	62.3	0.64	0.57	0.64	22.1
West: Bill Miller Dr (W)													
10	L2	All MCs	22 3.9	22 3.9	0.111	49.1	LOS D	0.6	4.4	0.93	0.70	0.93	21.5
Approach			22 3.9	22 3.9	0.111	49.1	LOS D	0.6	4.4	0.93	0.70	0.93	21.5
All Vehicles			2802 3.9	2521 4.3	0.531	10.6	LOS B	8.6	62.3	0.44	0.42	0.44	25.9

Site Level of Service (LOS) Method: Delay (SIDRA). Site LOS Method is specified in the Network Data dialog (Override Site Data tab).

Vehicle movement LOS values are based on average delay per movement.

Intersection and Approach LOS values are based on average delay for all vehicle movements.

Delay Model: SIDRA Standard (Control Delay: Geometric Delay is included).

Queue Model: SIDRA queue estimation methods are used for Back of Queue and Queue at Start of Green.

Gap-Acceptance Capacity Formula: SIDRA Standard (Akçelik M3D).

HV (%) values are calculated for All Movement Classes of All Heavy Vehicle Model Designation.

Arrival Flows used in performance calculations are adjusted to include any Initial Queued Demand and Upstream Capacity Constraint effects.

* Critical Movement (Signal Timing)

Pedestrian Movement Performance											
Mov ID	Crossing	Dem. Flow	Aver. Delay	Level of Service	AVERAGE BACK OF QUEUE		Prop. Que	Eff. Stop Rate	Travel Time	Travel Dist.	Aver. Speed
		ped/h	sec		[Ped ped]	[Dist] m			sec	m	m/sec
South: The Sands Ave (S)											
P1	Full	32	44.2	LOS E	0.1	0.1	0.94	0.94	59.6	20.0	0.34

East: Bill Miller Dr (E)											
P2	Full	32	44.2	LOS E	0.1	0.1	0.94	0.94	59.6	20.0	0.34
North: The Sands Ave (N)											
P3	Full	32	44.2	LOS E	0.1	0.1	0.94	0.94	59.6	20.0	0.34
West: Bill Miller Dr (W)											
P4	Full	32	44.2	LOS E	0.1	0.1	0.94	0.94	59.6	20.0	0.34
All Pedestrians		126	44.2	LOS E	0.1	0.1	0.94	0.94	59.6	20.0	0.34

Level of Service (LOS) Method: SIDRA Pedestrian LOS Method (Based on Average Delay)

Pedestrian movement LOS values are based on average delay per pedestrian movement.

Intersection LOS value for Pedestrians is based on average delay for all pedestrian movements.

SIDRA INTERSECTION 9.1 | Copyright © 2000-2024 Akcelik and Associates Pty Ltd | sidrasolutions.com

Organisation: AJW | Licence: NETWORK / 1PC | Processed: Friday, 27 March 2026 7:50:12 pm

Project: C:\Users\annaj\OneDrive\AW Consulting\Projects\Boffa Miskell Jobs\Wairakei South\ITA Work Feb 2026\Final SIDRA Modelling\Third Round Base Sidra File\2063_TTHM 10D Mitigated.sip9

MOVEMENT SUMMARY

Site: 2514p [2514 Sands_Te Okuroa_PM (Site Folder: General)]

Output produced by SIDRA INTERSECTION Version: 9.1.6.228

Network: N101
[2063_Opt10D_PM (Network Folder: General)]

Site Category: (None)

Signals - EQUISAT (Fixed-Time/SCATS) Coordinated Cycle Time = 100 seconds (Network Optimum Cycle Time - Minimum Delay)

Vehicle Movement Performance													
Mov ID	Turn	Mov Class	Demand Flows [Total HV]	Arrival Flows [Total HV]	Deg. Satn	Aver. Delay	Level of Service	Aver. Back Of Queue	Prop. Que	Eff. Stop Rate	Aver. No. of Cycles	Aver. Speed	
			veh/h %	veh/h %	v/c	sec		[Veh. veh	Dist] m			km/h	
South: The Sand Ave (S)													
1	L2	All MCs	398 7.5	310 7.7	0.221	8.5	LOS A	0.6	4.1	0.09	0.52	0.09	44.7
2	T1	All MCs	1317 7.5	1026 7.7	0.813	24.0	LOS C	13.7	102.5	0.84	0.78	0.89	23.5
3	R2	All MCs	792 7.5	617 7.7	1.094	154.7	LOS F	16.9	126.1	1.00	1.51	2.11	13.2
Approach			2506 7.5	1952 7.7	1.094	62.8	LOS E	16.9	126.1	0.77	0.97	1.15	18.4
East: Te Okuroa Dr (E)													
4	L2	All MCs	1327 7.5	1327 7.5	* 1.241	277.8	LOS F	52.4	390.3	1.00	1.99	2.90	6.1
5	T1	All MCs	102 7.5	102 7.5	0.305	39.1	LOS D	2.7	20.1	0.91	0.72	0.91	32.8
6	R2	All MCs	75 7.5	75 7.5	0.236	43.1	LOS D	2.0	14.5	0.90	0.75	0.90	23.4
Approach			1504 7.5	1504 7.5	1.241	249.9	LOS F	52.4	390.3	0.99	1.84	2.67	6.9
North: The Sand Ave (N)													
7	L2	All MCs	53 7.5	53 7.5	0.907	56.7	LOS E	11.9	88.9	1.00	1.09	1.28	23.5
8	T1	All MCs	993 7.5	993 7.5	* 0.907	47.6	LOS D	12.2	91.0	1.00	1.08	1.28	9.5
9	R2	All MCs	51 7.5	51 7.5	0.478	59.8	LOS E	1.6	12.0	1.00	0.76	1.00	21.7
Approach			1096 7.5	1096 7.5	0.907	48.6	LOS D	12.2	91.0	1.00	1.07	1.27	11.6
West: Te Okuroa Dr (W)													
10	L2	All MCs	84 7.5	84 7.5	0.553	25.5	LOS C	3.8	28.1	0.96	0.82	0.96	26.1
11	T1	All MCs	84 7.5	84 7.5	0.553	43.4	LOS D	3.8	28.1	0.96	0.82	0.96	34.1
12	R2	All MCs	308 7.5	308 7.5	* 0.654	49.6	LOS D	4.9	34.2	0.99	0.84	1.04	21.7
Approach			477 7.5	477 7.5	0.654	44.2	LOS D	4.9	34.2	0.98	0.83	1.01	25.0
All Vehicles			5583 7.5	5029 8.3	1.241	113.9	LOS F	52.4	390.3	0.91	1.24	1.62	11.4

Site Level of Service (LOS) Method: Delay (SIDRA). Site LOS Method is specified in the Network Data dialog (Override Site Data tab).

Vehicle movement LOS values are based on average delay per movement.

Intersection and Approach LOS values are based on average delay for all vehicle movements.

Delay Model: SIDRA Standard (Control Delay: Geometric Delay is included).

Queue Model: SIDRA queue estimation methods are used for Back of Queue and Queue at Start of Green.

Gap-Acceptance Capacity Formula: SIDRA Standard (Akçelik M3D).

HV (%) values are calculated for All Movement Classes of All Heavy Vehicle Model Designation.

Arrival Flows used in performance calculations are adjusted to include any Initial Queued Demand and Upstream Capacity Constraint effects.

* Critical Movement (Signal Timing)

Pedestrian Movement Performance											
Mov ID	Crossing	Dem. Flow	Aver. Delay	Level of Service	AVERAGE BACK OF QUEUE		Prop. Que	Eff. Stop Rate	Travel Time	Travel Dist.	Aver. Speed
		ped/h	sec		[Ped ped	Dist] m			sec	m	m/sec

South: The Sand Ave (S)											
P1	Full	32	44.2	LOS E	0.1	0.1	0.94	0.94	59.6	20.0	0.34
East: Te Okuroa Dr (E)											
P2	Full	32	44.2	LOS E	0.1	0.1	0.94	0.94	59.6	20.0	0.34
P2B	Slip/ Bypass	32	44.2	LOS E	0.1	0.1	0.94	0.94	59.6	20.0	0.34
North: The Sand Ave (N)											
P3	Full	32	44.2	LOS E	0.1	0.1	0.94	0.94	59.6	20.0	0.34
West: Te Okuroa Dr (W)											
P4	Full	32	44.2	LOS E	0.1	0.1	0.94	0.94	59.6	20.0	0.34
All Pedestrians		158	44.2	LOS E	0.1	0.1	0.94	0.94	59.6	20.0	0.34

Level of Service (LOS) Method: SIDRA Pedestrian LOS Method (Based on Average Delay)

Pedestrian movement LOS values are based on average delay per pedestrian movement.

Intersection LOS value for Pedestrians is based on average delay for all pedestrian movements.

SIDRA INTERSECTION 9.1 | Copyright © 2000-2024 Akcelik and Associates Pty Ltd | sidrasolutions.com

Organisation: AJW | Licence: NETWORK / 1PC | Processed: Friday, 27 March 2026 7:50:12 pm

Project: C:\Users\annaj\OneDrive\AW Consulting\Projects\Boffa Miskell Jobs\Wairakei South\ITA Work Feb 2026\Final SIDRA Modelling\Third Round Base Sidra File\2063_TTHM 10D Mitigated.sip9

MOVEMENT SUMMARY

Site: 10003p [10003_PM (Site Folder: General)]

Output produced by SIDRA INTERSECTION Version: 9.1.6.228

Network: N101
[2063_Opt10D_PM (Network Folder: General)]

NA

Site Category: (None)

Signals - EQUISAT (Fixed-Time/SCATS) Isolated Cycle Time = 120 seconds (Site Practical Cycle Time)

Vehicle Movement Performance															
Mov ID	Turn	Mov Class	Demand Flows		Arrival Flows		Deg. Satn	Aver. Delay	Level of Service	Aver. Back Of Queue	Prop. Que	Eff. Stop Rate	Aver. No. of Cycles	Aver. Speed	
			[Total HV]	%	[Total HV]	%	v/c	sec		[Veh. veh	Dist]			km/h	
			veh/h		veh/h					veh	m				
South: Road 2															
1	L2	All MCs	8	6.6	8	6.6	0.056	32.9	LOS C	0.7	5.4	0.77	0.61	0.77	12.7
2	T1	All MCs	19	6.6	19	6.6	0.056	37.8	LOS D	0.7	5.4	0.77	0.61	0.77	28.5
3	R2	All MCs	426	6.6	426	6.6	*0.848	63.4	LOS E	9.3	68.7	1.00	1.00	1.26	8.1
Approach			454	6.6	454	6.6	0.848	61.8	LOS E	9.3	68.7	0.99	0.97	1.23	9.1
East: Road 1															
4	L2	All MCs	188	6.6	175	6.6	0.112	5.0	LOSA	0.4	3.0	0.13	0.54	0.13	42.0
5	T1	All MCs	420	6.6	390	6.6	0.284	28.7	LOS C	4.9	36.3	0.75	0.63	0.75	24.1
6	R2	All MCs	80	6.6	74	6.6	*0.838	74.9	LOS E	3.0	22.1	1.00	0.94	1.36	22.5
Approach			688	6.6	639	6.6	0.838	27.6	LOS C	4.9	36.3	0.61	0.64	0.65	27.2
North: Road 2															
7	L2	All MCs	66	6.6	66	6.6	0.202	26.9	LOS C	1.5	11.0	0.69	0.71	0.69	29.2
8	T1	All MCs	7	6.6	7	6.6	*0.107	51.0	LOS D	0.8	5.8	0.92	0.69	0.92	23.6
9	R2	All MCs	17	6.6	17	6.6	0.107	55.6	LOS E	0.8	5.8	0.92	0.69	0.92	20.5
Approach			91	6.6	91	6.6	0.202	34.2	LOS C	1.5	11.0	0.75	0.70	0.75	26.5
West: Road 1															
10	L2	All MCs	36	6.6	36	6.6	0.866	40.5	LOS D	12.7	94.1	0.99	1.05	1.22	27.6
11	T1	All MCs	632	6.6	632	6.6	*0.866	53.3	LOS D	14.0	103.6	0.99	1.05	1.21	19.1
12	R2	All MCs	12	6.6	12	6.6	0.131	66.8	LOS E	0.4	3.1	0.98	0.68	0.98	19.2
Approach			679	6.6	679	6.6	0.866	52.8	LOS D	14.0	103.6	0.99	1.04	1.21	19.7
All Vehicles			1912	6.6	1862	6.8	0.866	45.4	LOS D	14.0	103.6	0.85	0.87	1.00	19.6

Site Level of Service (LOS) Method: Delay (SIDRA). Site LOS Method is specified in the Network Data dialog (Override Site Data tab).

Vehicle movement LOS values are based on average delay per movement.

Intersection and Approach LOS values are based on average delay for all vehicle movements.

Delay Model: SIDRA Standard (Control Delay; Geometric Delay is included).

Queue Model: SIDRA queue estimation methods are used for Back of Queue and Queue at Start of Green.

Gap-Acceptance Capacity Formula: SIDRA Standard (Akçelik M3D).

HV (%) values are calculated for All Movement Classes of All Heavy Vehicle Model Designation.

Arrival Flows used in performance calculations are adjusted to include any Initial Queued Demand and Upstream Capacity Constraint effects.

* Critical Movement (Signal Timing)

Pedestrian Movement Performance											
Mov ID	Crossing	Dem. Flow	Aver. Delay	Level of Service	AVERAGE BACK OF QUEUE		Prop. Que	Eff. Stop Rate	Travel Time	Travel Dist.	Aver. Speed
		ped/h	sec		[Ped ped	Dist]			sec	m	m/sec
					ped	m					
South: Road 2											
P1	Full	32	54.2	LOS E	0.1	0.1	0.95	0.95	208.1	200.0	0.96

East: Road 1											
P2	Full	32	54.2	LOS E	0.1	0.1	0.95	0.95	208.1	200.0	0.96
North: Road 2											
P3	Full	32	54.2	LOS E	0.1	0.1	0.95	0.95	208.1	200.0	0.96
West: Road 1											
P4	Full	32	54.2	LOS E	0.1	0.1	0.95	0.95	208.1	200.0	0.96
All Pedestrians		126	54.2	LOS E	0.1	0.1	0.95	0.95	208.1	200.0	0.96

Level of Service (LOS) Method: SIDRA Pedestrian LOS Method (Based on Average Delay)

Pedestrian movement LOS values are based on average delay per pedestrian movement.

Intersection LOS value for Pedestrians is based on average delay for all pedestrian movements.

SIDRA INTERSECTION 9.1 | Copyright © 2000-2024 Akcelik and Associates Pty Ltd | sidrasolutions.com

Organisation: AJW | Licence: NETWORK / 1PC | Processed: Friday, 27 March 2026 7:50:12 pm

Project: C:\Users\annaj\OneDrive\AW Consulting\Projects\Boffa Miskell Jobs\Wairakei South\ITA Work Feb 2026\Final SIDRA Modelling\Third Round Base Sidra File\2063_TTHM 10D Mitigated.sip9

MOVEMENT SUMMARY

Site: 10007p [10007_PM (Site Folder: General)]

Output produced by SIDRA INTERSECTION Version: 9.1.6.228

Network: N101
[2063_Opt10D_PM (Network Folder: General)]

NA

Site Category: (None)

Signals - EQUISAT (Fixed-Time/SCATS) Isolated Cycle Time = 70 seconds (Site Practical Cycle Time)

Vehicle Movement Performance															
Mov ID	Turn	Mov Class	Demand Flows		Arrival Flows		Deg. Satn	Aver. Delay	Level of Service	Aver. Back Of Queue		Prop. Que	Eff. Stop Rate	Aver. No. of Cycles	Aver. Speed
			[Total HV] veh/h	%	[Total HV] veh/h	%				[Veh. veh	Dist] m				
SouthEast: Road 4															
21	L2	All MCs	21	7.8	21	7.8	0.073	25.3	LOS C	0.6	4.2	0.77	0.65	0.77	30.8
22	T1	All MCs	15	7.8	15	7.8	0.073	20.6	LOS C	0.6	4.2	0.77	0.65	0.77	37.7
23	R2	All MCs	11	7.8	11	7.8	*0.070	38.2	LOS D	0.2	1.6	0.95	0.67	0.95	24.7
Approach			46	7.8	46	7.8	0.073	26.7	LOS C	0.6	4.2	0.81	0.65	0.81	32.2
NorthEast: Road 1															
24	L2	All MCs	11	7.8	10	7.9	0.429	34.7	LOS C	2.5	18.5	0.95	0.75	0.95	33.8
25	T1	All MCs	257	7.8	240	7.9	0.429	30.1	LOS C	2.5	18.5	0.95	0.75	0.95	25.7
26	R2	All MCs	175	7.8	163	7.9	*0.649	37.7	LOS D	3.5	26.0	0.99	0.84	1.08	31.3
Approach			442	7.8	413	7.9	0.649	33.2	LOS C	3.5	26.0	0.97	0.79	1.00	28.9
NorthWest: Road 4															
27	L2	All MCs	328	7.8	328	7.8	0.704	31.3	LOS C	6.8	50.5	0.96	0.87	1.02	26.7
28	T1	All MCs	8	7.8	8	7.8	*0.704	26.6	LOS C	6.8	50.5	0.96	0.87	1.02	34.9
29	R2	All MCs	4	7.8	4	7.8	0.028	37.7	LOS D	0.1	0.6	0.94	0.63	0.94	24.4
Approach			341	7.8	341	7.8	0.704	31.2	LOS C	6.8	50.5	0.96	0.87	1.02	27.0
SouthWest: Road 1															
30	L2	All MCs	58	7.8	58	7.8	0.688	37.3	LOS D	4.2	31.6	1.00	0.87	1.10	29.0
31	T1	All MCs	340	7.8	340	7.8	*0.688	32.7	LOS C	4.3	32.0	1.00	0.87	1.10	15.8
32	R2	All MCs	48	7.8	48	7.8	0.193	34.4	LOS C	0.9	7.0	0.92	0.73	0.92	29.3
Approach			446	7.8	446	7.8	0.688	33.5	LOS C	4.3	32.0	0.99	0.86	1.08	20.6
All Vehicles			1276	7.8	1246	8.0	0.704	32.5	LOS C	6.8	50.5	0.97	0.83	1.03	26.0

Site Level of Service (LOS) Method: Delay (SIDRA). Site LOS Method is specified in the Network Data dialog (Override Site Data tab).

Vehicle movement LOS values are based on average delay per movement.

Intersection and Approach LOS values are based on average delay for all vehicle movements.

Delay Model: SIDRA Standard (Control Delay; Geometric Delay is included).

Queue Model: SIDRA queue estimation methods are used for Back of Queue and Queue at Start of Green.

Gap-Acceptance Capacity Formula: SIDRA Standard (Akçelik M3D).

HV (%) values are calculated for All Movement Classes of All Heavy Vehicle Model Designation.

Arrival Flows used in performance calculations are adjusted to include any Initial Queued Demand and Upstream Capacity Constraint effects.

* Critical Movement (Signal Timing)

Pedestrian Movement Performance											
Mov ID	Crossing	Dem. Flow	Aver. Delay	Level of Service	AVERAGE BACK OF QUEUE		Prop. Que	Eff. Stop Rate	Travel Time	Travel Dist.	Aver. Speed
					[Ped ped	Dist] m					
SouthEast: Road 4											
P5	Full	32	29.3	LOS C	0.1	0.1	0.92	0.92	183.1	200.0	1.09

NorthEast: Road 1											
P6	Full	32	29.3	LOS C	0.1	0.1	0.92	0.92	183.1	200.0	1.09
NorthWest: Road 4											
P7	Full	32	29.3	LOS C	0.1	0.1	0.92	0.92	183.1	200.0	1.09
SouthWest: Road 1											
P8	Full	32	29.3	LOS C	0.1	0.1	0.92	0.92	183.1	200.0	1.09
All Pedestrians		126	29.3	LOS C	0.1	0.1	0.92	0.92	183.1	200.0	1.09

Level of Service (LOS) Method: SIDRA Pedestrian LOS Method (Based on Average Delay)

Pedestrian movement LOS values are based on average delay per pedestrian movement.

Intersection LOS value for Pedestrians is based on average delay for all pedestrian movements.

SIDRA INTERSECTION 9.1 | Copyright © 2000-2024 Akcelik and Associates Pty Ltd | sidrasolutions.com

Organisation: AJW | Licence: NETWORK / 1PC | Processed: Friday, 27 March 2026 7:50:12 pm

Project: C:\Users\annaj\OneDrive\AW Consulting\Projects\Boffa Miskell Jobs\Wairakei South\ITA Work Feb 2026\Final SIDRA Modelling\Third Round Base Sidra File\2063_TTHM 10D Mitigated.sip9

MOVEMENT SUMMARY

Site: 10008p [10008_PM (Site Folder: General)]

Output produced by SIDRA INTERSECTION Version: 9.1.6.228

Network: N101
[2063_Opt10D_PM (Network Folder: General)]

New Site

Site Category: (None)

Signals - EQUISAT (Fixed-Time/SCATS) Isolated Cycle Time = 70 seconds (Site Practical Cycle Time)

Vehicle Movement Performance															
Mov ID	Turn	Mov Class	Demand Flows		Arrival Flows		Deg. Satn	Aver. Delay	Level of Service	Aver. Back Of Queue		Prop. Que	Eff. Stop Rate	Aver. No. of Cycles	Aver. Speed
			[Total HV]	%	[Total HV]	%				[Veh. veh	Dist]				
South: Road 1															
1	L2	All MCs	4	11.4	4	11.4	0.512	23.8	LOS C	2.9	22.5	0.95	0.77	0.95	26.2
2	T1	All MCs	288	11.4	288	11.4	*0.512	30.4	LOS C	2.9	22.6	0.96	0.77	0.96	26.0
3	R2	All MCs	53	11.4	53	11.4	0.179	32.4	LOS C	1.0	7.5	0.89	0.73	0.89	34.0
Approach			345	11.4	345	11.4	0.512	30.6	LOS C	2.9	22.6	0.95	0.76	0.95	27.9
East: Bell Road															
4	L2	All MCs	202	11.4	202	11.4	0.148	5.3	LOSA	0.5	3.8	0.22	0.57	0.22	44.1
5	T1	All MCs	226	11.4	226	11.4	*0.513	25.5	LOS C	4.2	32.5	0.91	0.76	0.91	30.9
6	R2	All MCs	72	11.4	72	11.4	*0.486	40.4	LOS D	1.6	12.0	0.99	0.76	0.99	25.2
Approach			500	11.4	500	11.4	0.513	19.5	LOS B	4.2	32.5	0.65	0.68	0.65	33.9
North: Road 1															
7	L2	All MCs	8	11.4	8	11.7	0.014	21.6	LOS C	0.1	0.9	0.70	0.64	0.70	35.0
8	T1	All MCs	114	11.4	107	11.7	0.188	28.7	LOS C	1.0	7.8	0.90	0.68	0.90	17.6
9	R2	All MCs	160	11.4	151	11.7	*0.513	34.4	LOS C	3.0	23.2	0.95	0.79	0.95	15.7
Approach			282	11.4	266	11.7	0.513	31.7	LOS C	3.0	23.2	0.93	0.74	0.93	17.3
West: Bell Road															
10	L2	All MCs	79	11.4	79	11.4	0.064	6.5	LOSA	0.4	2.7	0.31	0.58	0.31	41.8
11	T1	All MCs	61	11.4	61	11.4	0.138	22.8	LOS C	1.0	7.8	0.82	0.63	0.82	38.1
12	R2	All MCs	1	11.4	1	11.4	0.007	37.2	LOS D	0.0	0.2	0.93	0.59	0.93	23.5
Approach			141	11.4	141	11.4	0.138	13.8	LOS B	1.0	7.8	0.54	0.60	0.54	39.3
All Vehicles			1268	11.4	1252	11.6	0.513	24.5	LOS C	4.2	32.5	0.78	0.71	0.78	29.9

Site Level of Service (LOS) Method: Delay (SIDRA). Site LOS Method is specified in the Network Data dialog (Override Site Data tab).

Vehicle movement LOS values are based on average delay per movement.

Intersection and Approach LOS values are based on average delay for all vehicle movements.

Delay Model: SIDRA Standard (Control Delay; Geometric Delay is included).

Queue Model: SIDRA queue estimation methods are used for Back of Queue and Queue at Start of Green.

Gap-Acceptance Capacity Formula: SIDRA Standard (Akçelik M3D).

HV (%) values are calculated for All Movement Classes of All Heavy Vehicle Model Designation.

Arrival Flows used in performance calculations are adjusted to include any Initial Queued Demand and Upstream Capacity Constraint effects.

* Critical Movement (Signal Timing)

Pedestrian Movement Performance											
Mov ID	Crossing	Dem. Flow	Aver. Delay	Level of Service	AVERAGE BACK OF QUEUE		Prop. Que	Eff. Stop Rate	Travel Time	Travel Dist.	Aver. Speed
					[Ped ped	Dist]					
South: Road 1											
P1	Full	32	29.3	LOS C	0.1	0.1	0.92	0.92	183.1	200.0	1.09

East: Bell Road											
P2	Full	32	29.3	LOS C	0.1	0.1	0.92	0.92	183.1	200.0	1.09
North: Road 1											
P3	Full	32	29.3	LOS C	0.1	0.1	0.92	0.92	183.1	200.0	1.09
West: Bell Road											
P4	Full	32	29.3	LOS C	0.1	0.1	0.92	0.92	183.1	200.0	1.09
All Pedestrians		126	29.3	LOS C	0.1	0.1	0.92	0.92	183.1	200.0	1.09

Level of Service (LOS) Method: SIDRA Pedestrian LOS Method (Based on Average Delay)

Pedestrian movement LOS values are based on average delay per pedestrian movement.

Intersection LOS value for Pedestrians is based on average delay for all pedestrian movements.

SIDRA INTERSECTION 9.1 | Copyright © 2000-2024 Akcelik and Associates Pty Ltd | sidrasolutions.com

Organisation: AJW | Licence: NETWORK / 1PC | Processed: Friday, 27 March 2026 7:50:12 pm

Project: C:\Users\annaj\OneDrive\AW Consulting\Projects\Boffa Miskell Jobs\Wairakei South\ITA Work Feb 2026\Final SIDRA Modelling\Third Round Base Sidra File\2063_TTHM 10D Mitigated.sip9

MOVEMENT SUMMARY

Site: 10015p [10015_PM (Site Folder: General)]

Output produced by SIDRA INTERSECTION Version: 9.1.6.228

Network: N101
[2063_Opt10D_PM (Network Folder: General)]

New Site

Site Category: (None)

Signals - EQUISAT (Fixed-Time/SCATS) Isolated Cycle Time = 70 seconds (Site Practical Cycle Time)

Vehicle Movement Performance															
Mov ID	Turn	Mov Class	Demand Flows [Total HV] veh/h %		Arrival Flows [Total HV] veh/h %		Deg. Satn v/c	Aver. Delay sec	Level of Service	Aver. Back Of Queue [Veh. veh]	Prop. Que	Eff. Stop Rate	Aver. No. of Cycles	Aver. Speed km/h	
South: Road 1															
1	L2	All MCs	5	13.0	5	13.0	0.217	23.0	LOS C	1.2	9.0	0.90	0.69	0.90	34.9
2	T1	All MCs	118	13.0	118	13.0	0.217	28.9	LOS C	1.2	9.1	0.90	0.69	0.90	26.6
3	R2	All MCs	1	13.0	1	13.0	0.004	30.7	LOS C	0.0	0.1	0.84	0.59	0.84	33.9
Approach			124	13.0	124	13.0	0.217	28.7	LOS C	1.2	9.1	0.90	0.69	0.90	27.3
East: Road 6															
4	L2	All MCs	1	13.0	1	13.0	0.058	14.2	LOS B	0.4	3.1	0.78	0.58	0.78	31.8
5	T1	All MCs	24	13.0	24	13.0	0.058	21.9	LOS C	0.4	3.1	0.78	0.58	0.78	38.9
6	R2	All MCs	56	13.0	56	13.0	*0.383	40.0	LOS D	1.2	9.3	0.98	0.74	0.98	24.2
Approach			81	13.0	81	13.0	0.383	34.3	LOS C	1.2	9.3	0.92	0.69	0.92	29.4
North: Road 1															
7	L2	All MCs	29	13.0	29	13.1	0.052	22.0	LOS C	0.4	3.2	0.71	0.68	0.71	37.0
8	T1	All MCs	102	13.0	100	13.1	*0.230	28.7	LOS C	1.2	9.7	0.90	0.68	0.90	26.6
9	R2	All MCs	131	13.0	128	13.1	*0.439	34.0	LOS C	2.5	19.6	0.94	0.78	0.94	33.1
Approach			262	13.0	257	13.1	0.439	30.6	LOS C	2.5	19.6	0.90	0.73	0.90	31.8
West: Road 6															
10	L2	All MCs	83	13.0	83	13.0	0.139	17.3	LOS B	1.3	9.7	0.67	0.69	0.67	34.0
11	T1	All MCs	11	13.0	11	13.0	*0.139	28.9	LOS C	1.3	9.7	0.67	0.69	0.67	40.1
12	R2	All MCs	2	13.0	2	13.0	0.014	37.5	LOS D	0.0	0.3	0.93	0.61	0.93	25.6
Approach			96	13.0	96	13.0	0.139	19.0	LOS B	1.3	9.7	0.67	0.69	0.67	34.8
All Vehicles			563	13.0	558	13.1	0.439	28.7	LOS C	2.5	19.6	0.86	0.71	0.86	31.0

Site Level of Service (LOS) Method: Delay (SIDRA). Site LOS Method is specified in the Network Data dialog (Override Site Data tab).

Vehicle movement LOS values are based on average delay per movement.

Intersection and Approach LOS values are based on average delay for all vehicle movements.

Delay Model: SIDRA Standard (Control Delay; Geometric Delay is included).

Queue Model: SIDRA queue estimation methods are used for Back of Queue and Queue at Start of Green.

Gap-Acceptance Capacity Formula: SIDRA Standard (Akçelik M3D).

HV (%) values are calculated for All Movement Classes of All Heavy Vehicle Model Designation.

Arrival Flows used in performance calculations are adjusted to include any Initial Queued Demand and Upstream Capacity Constraint effects.

* Critical Movement (Signal Timing)

Pedestrian Movement Performance											
Mov ID	Crossing	Dem. Flow ped/h	Aver. Delay sec	Level of Service	AVERAGE BACK OF QUEUE [Ped Dist] ped m		Prop. Que	Eff. Stop Rate	Travel Time sec	Travel Dist. m	Aver. Speed m/sec
South: Road 1											
P1	Full	32	29.3	LOS C	0.1	0.1	0.92	0.92	183.1	200.0	1.09

East: Road 6											
P2	Full	32	29.3	LOS C	0.1	0.1	0.92	0.92	183.1	200.0	1.09
North: Road 1											
P3	Full	32	29.3	LOS C	0.1	0.1	0.92	0.92	183.1	200.0	1.09
West: Road 6											
P4	Full	32	29.3	LOS C	0.1	0.1	0.92	0.92	183.1	200.0	1.09
All Pedestrians		126	29.3	LOS C	0.1	0.1	0.92	0.92	183.1	200.0	1.09

Level of Service (LOS) Method: SIDRA Pedestrian LOS Method (Based on Average Delay)

Pedestrian movement LOS values are based on average delay per pedestrian movement.

Intersection LOS value for Pedestrians is based on average delay for all pedestrian movements.

SIDRA INTERSECTION 9.1 | Copyright © 2000-2024 Akcelik and Associates Pty Ltd | sidrasolutions.com

Organisation: AJW | Licence: NETWORK / 1PC | Processed: Friday, 27 March 2026 7:50:12 pm

Project: C:\Users\annaj\OneDrive\AW Consulting\Projects\Boffa Miskell Jobs\Wairakei South\ITA Work Feb 2026\Final SIDRA Modelling\Third Round Base Sidra File\2063_TTHM 10D Mitigated.sip9

MOVEMENT SUMMARY

Site: 10016p [10016_PM (Site Folder: General)]

Output produced by SIDRA INTERSECTION Version: 9.1.6.228

Network: N101
[2063_Opt10D_PM (Network Folder: General)]

New Site

Site Category: (None)

Signals - EQUISAT (Fixed-Time/SCATS) Isolated Cycle Time = 60 seconds (Site Practical Cycle Time)

Vehicle Movement Performance															
Mov ID	Turn	Mov Class	Demand Flows [Total HV]		Arrival Flows [Total HV]		Deg. Satn	Aver. Delay	Level of Service	Aver. Back Of Queue		Prop. Que	Eff. Stop Rate	Aver. No. of Cycles	Aver. Speed
			veh/h	%	veh/h	%	v/c	sec		[Veh. veh	Dist] m				km/h
South: Road 1															
1	L2	All MCs	1	13.6	1	13.6	0.010	26.6	LOS C	0.0	0.4	0.84	0.56	0.84	37.9
2	T1	All MCs	2	13.6	2	13.6	0.010	21.9	LOS C	0.0	0.4	0.84	0.56	0.84	30.6
3	R2	All MCs	1	13.6	1	13.6	0.005	29.5	LOS C	0.0	0.1	0.88	0.59	0.88	34.9
Approach			4	13.6	4	13.6	0.010	24.9	LOS C	0.0	0.4	0.85	0.57	0.85	34.3
East: Road 7															
4	L2	All MCs	1	13.6	1	13.6	0.048	16.0	LOS B	0.2	1.8	0.83	0.59	0.83	37.6
5	T1	All MCs	15	13.6	15	13.6	0.048	22.2	LOS C	0.2	1.8	0.83	0.59	0.83	39.3
6	R2	All MCs	32	13.6	32	13.6	*0.187	33.4	LOS C	0.6	4.4	0.95	0.71	0.95	26.3
Approach			47	13.6	47	13.6	0.187	29.5	LOS C	0.6	4.4	0.91	0.67	0.91	31.7
North: Road 1															
7	L2	All MCs	18	13.6	18	13.7	0.060	27.2	LOS C	0.3	2.2	0.85	0.68	0.85	35.2
8	T1	All MCs	1	13.6	1	13.7	*0.060	22.5	LOS C	0.3	2.2	0.85	0.68	0.85	36.0
9	R2	All MCs	88	13.6	87	13.7	*0.384	32.1	LOS C	1.5	11.9	0.95	0.76	0.95	34.4
Approach			107	13.6	105	13.7	0.384	31.2	LOS C	1.5	11.9	0.94	0.75	0.94	34.6
West: Road 7															
10	L2	All MCs	88	13.6	88	13.6	0.158	17.7	LOS B	1.2	9.2	0.71	0.70	0.71	35.4
11	T1	All MCs	7	13.6	7	13.6	*0.158	25.5	LOS C	1.2	9.2	0.71	0.70	0.71	40.8
12	R2	All MCs	1	13.6	1	13.6	0.006	31.8	LOS C	0.0	0.1	0.92	0.59	0.92	35.1
Approach			97	13.6	97	13.6	0.158	18.5	LOS B	1.2	9.2	0.71	0.70	0.71	36.0
All Vehicles			256	13.6	254	13.7	0.384	25.9	LOS C	1.5	11.9	0.84	0.71	0.84	34.5

Site Level of Service (LOS) Method: Delay (SIDRA). Site LOS Method is specified in the Network Data dialog (Override Site Data tab).

Vehicle movement LOS values are based on average delay per movement.

Intersection and Approach LOS values are based on average delay for all vehicle movements.

Delay Model: SIDRA Standard (Control Delay; Geometric Delay is included).

Queue Model: SIDRA queue estimation methods are used for Back of Queue and Queue at Start of Green.

Gap-Acceptance Capacity Formula: SIDRA Standard (Akçelik M3D).

HV (%) values are calculated for All Movement Classes of All Heavy Vehicle Model Designation.

Arrival Flows used in performance calculations are adjusted to include any Initial Queued Demand and Upstream Capacity Constraint effects.

* Critical Movement (Signal Timing)

Pedestrian Movement Performance											
Mov ID	Crossing	Dem. Flow	Aver. Delay	Level of Service	AVERAGE BACK OF QUEUE		Prop. Que	Eff. Stop Rate	Travel Time	Travel Dist.	Aver. Speed
		ped/h	sec		[Ped ped	Dist] m			sec	m	m/sec
South: Road 1											
P1	Full	32	24.3	LOS C	0.0	0.0	0.90	0.90	178.2	200.0	1.12

East: Road 7											
P2	Full	32	24.3	LOS C	0.0	0.0	0.90	0.90	178.2	200.0	1.12
North: Road 1											
P3	Full	32	24.3	LOS C	0.0	0.0	0.90	0.90	178.2	200.0	1.12
West: Road 7											
P4	Full	32	24.3	LOS C	0.0	0.0	0.90	0.90	178.2	200.0	1.12
All Pedestrians		126	24.3	LOS C	0.0	0.0	0.90	0.90	178.2	200.0	1.12

Level of Service (LOS) Method: SIDRA Pedestrian LOS Method (Based on Average Delay)

Pedestrian movement LOS values are based on average delay per pedestrian movement.

Intersection LOS value for Pedestrians is based on average delay for all pedestrian movements.

SIDRA INTERSECTION 9.1 | Copyright © 2000-2024 Akcelik and Associates Pty Ltd | sidrasolutions.com

Organisation: AJW | Licence: NETWORK / 1PC | Processed: Friday, 27 March 2026 7:50:12 pm

Project: C:\Users\annaj\OneDrive\AW Consulting\Projects\Boffa Miskell Jobs\Wairakei South\ITA Work Feb 2026\Final SIDRA Modelling\Third Round Base Sidra File\2063_TTHM 10D Mitigated.sip9

MOVEMENT SUMMARY

Site: 10013p [10013_PM (Site Folder: General)]

Output produced by SIDRA INTERSECTION Version: 9.1.6.228

Network: N101
[2063_Opt10D_PM (Network Folder: General)]

Site Category: (None)
Roundabout

Vehicle Movement Performance															
Mov ID	Turn	Mov Class	Demand Flows		Arrival Flows		Deg. Satn	Aver. Delay	Level of Service	Aver. Back Of Queue		Prop. Que	Eff. Stop Rate	Aver. No. of Cycles	Aver. Speed
			[Total HV]	%	[Total HV]	%				[Veh. veh	Dist]				
South: Road 4															
1	L2	All MCs	323	3.9	323	3.9	0.484	6.0	LOS A	1.6	11.3	0.74	0.61	0.74	40.7
2	T1	All MCs	108	3.9	108	3.9	0.484	5.8	LOS A	1.6	11.3	0.74	0.61	0.74	43.2
3	R2	All MCs	38	3.9	38	3.9	0.484	10.8	LOS B	1.6	11.3	0.74	0.61	0.74	40.7
Approach			469	3.9	469	3.9	0.484	6.4	LOS A	1.6	11.3	0.74	0.61	0.74	41.5
East: Bell Road															
4	L2	All MCs	68	3.9	67	3.9	0.391	5.4	LOS A	0.9	6.5	0.50	0.58	0.50	45.0
5	T1	All MCs	288	3.9	282	3.9	0.391	5.2	LOS A	0.9	6.5	0.50	0.58	0.50	42.7
6	R2	All MCs	35	3.9	34	3.9	0.391	10.2	LOS B	0.9	6.5	0.50	0.58	0.50	43.5
Approach			392	3.9	383	3.9	0.391	5.7	LOS A	0.9	6.5	0.50	0.58	0.50	43.4
North: Road 4															
7	L2	All MCs	1	3.9	1	3.9	0.163	4.7	LOS A	0.4	2.8	0.56	0.63	0.56	34.6
8	T1	All MCs	34	3.9	34	3.9	0.163	4.5	LOS A	0.4	2.8	0.56	0.63	0.56	41.8
9	R2	All MCs	125	3.9	125	3.9	0.163	9.5	LOS A	0.4	2.8	0.56	0.63	0.56	34.6
Approach			160	3.9	160	3.9	0.163	8.4	LOS A	0.4	2.8	0.56	0.63	0.56	37.1
West: Bell Road															
10	L2	All MCs	205	3.9	205	3.9	0.458	3.9	LOS A	1.5	10.7	0.52	0.53	0.52	48.3
11	T1	All MCs	102	3.9	102	3.9	0.458	3.7	LOS A	1.5	10.7	0.52	0.53	0.52	48.4
12	R2	All MCs	254	3.9	254	3.9	0.458	8.6	LOS A	1.5	10.7	0.52	0.53	0.52	48.2
Approach			561	3.9	561	3.9	0.458	6.0	LOS A	1.5	10.7	0.52	0.53	0.52	48.3
All Vehicles			1582	3.9	1573	3.9	0.484	6.3	LOS A	1.6	11.3	0.59	0.58	0.59	46.7

Site Level of Service (LOS) Method: Delay (SIDRA). Site LOS Method is specified in the Network Data dialog (Override Site Data tab).

Roundabout LOS Method: SIDRA Roundabout LOS.

Vehicle movement LOS values are based on average delay per movement.

Intersection and Approach LOS values are based on average delay for all vehicle movements.

Roundabout Capacity Model: SIDRA Standard.

Delay Model: SIDRA Standard (Control Delay: Geometric Delay is included).

Queue Model: SIDRA queue estimation methods are used for Back of Queue and Queue at Start of Gap.

Gap-Acceptance Capacity Formula: SIDRA Standard (Akçelik M3D).

HV (%) values are calculated for All Movement Classes of All Heavy Vehicle Model Designation.

Arrival Flows used in performance calculations are adjusted to include any Initial Queued Demand and Upstream Capacity Constraint effects.

SIDRA INTERSECTION 9.1 | Copyright © 2000-2024 Akcelik and Associates Pty Ltd | sidrasolutions.com

Organisation: AJW | Licence: NETWORK / 1PC | Processed: Friday, 27 March 2026 7:50:12 pm

Project: C:\Users\lannaj\OneDrive\AW Consulting\Projects\Boffa Miskell Jobs\Wairakei South\ITA Work Feb 2026\Final SIDRA Modelling\Third Round Base Sidra File\2063_TTHM 10D Mitigated.sip9

MOVEMENT SUMMARY

 Site: 101 [1348 Bell Rd Parton Rd PM (Site Folder: General)]

Output produced by SIDRA INTERSECTION Version: 9.1.6.228

 Network: N101
[2063_Opt10D_PM (Network Folder: General)]

New Site
Site Category: (None)
Stop (Two-Way)

Vehicle Movement Performance															
Mov ID	Turn	Mov Class	Demand Flows		Arrival Flows		Deg. Satn	Aver. Delay	Level of Service	Aver. Back Of Queue	Prop. Que	Eff. Stop Rate	Aver. No. of Cycles	Aver. Speed	
			[Total HV] veh/h	%	[Total HV] veh/h	%									v/c
East: Bell Road															
5	T1	All MCs	532	3.7	527	3.7	0.277	0.2	LOS A	0.0	0.0	0.00	0.00	0.00	99.8
6	R2	All MCs	213	3.7	211	3.7	0.203	10.2	LOS B	0.4	2.7	0.56	0.76	0.56	88.0
Approach			744	3.7	738	3.7	0.277	3.0	NA	0.4	2.7	0.16	0.22	0.16	95.7
North: Parton Road															
7	L2	All MCs	172	3.7	172	3.7	0.182	11.8	LOS B	0.3	2.3	0.48	0.90	0.48	63.6
9	R2	All MCs	143	3.7	143	3.7	0.298	17.2	LOS C	0.5	3.3	0.75	1.03	0.90	54.4
Approach			315	3.7	315	3.7	0.298	14.3	LOS B	0.5	3.3	0.60	0.96	0.67	59.1
West: Bell Road															
10	L2	All MCs	131	3.7	131	3.7	0.272	8.0	LOS A	0.0	0.0	0.00	0.17	0.00	84.0
11	T1	All MCs	380	3.7	380	3.7	0.272	0.0	LOS A	0.0	0.0	0.00	0.17	0.00	92.5
Approach			511	3.7	511	3.7	0.272	2.1	NA	0.0	0.0	0.00	0.17	0.00	89.1
All Vehicles			1569	3.7	1563	3.7	0.298	5.0	NA	0.5	3.3	0.20	0.35	0.21	91.4

Site Level of Service (LOS) Method: Delay (SIDRA). Site LOS Method is specified in the Network Data dialog (Override Site Data tab).

Vehicle movement LOS values are based on average delay per movement.

Minor Road Approach LOS values are based on average delay for all vehicle movements.

NA (TWSC): Level of Service is not defined for major road approaches or the intersection as a whole for Two-Way Sign Control (HCM LOS rule).

Two-Way Sign Control Capacity Model: SIDRA Standard.

Delay Model: SIDRA Standard (Control Delay: Geometric Delay is included).

Queue Model: SIDRA queue estimation methods are used for Back of Queue and Queue at Start of Gap.

Gap-Acceptance Capacity Formula: SIDRA Standard (Akçelik M3D).

HV (%) values are calculated for All Movement Classes of All Heavy Vehicle Model Designation.

Arrival Flows used in performance calculations are adjusted to include any Initial Queued Demand and Upstream Capacity Constraint effects.

SIDRA INTERSECTION 9.1 | Copyright © 2000-2024 Akcelik and Associates Pty Ltd | sidrasolutions.com

Organisation: AJW | Licence: NETWORK / 1PC | Processed: Friday, 27 March 2026 7:50:12 pm

Project: C:\Users\anna\OneDrive\AW Consulting\Projects\Bofa Miskell Jobs\Wairakei South\ITA Work Feb 2026\Final SIDRA Modelling\Third Round Base Sidra File\2063_TTHM 10D Mitigated.sip9

USER REPORT FOR NETWORK SITE

Project: 2063_TTHM 10D Mitigated_v1

Template: Default Site User Report

 Site: 101 [1348 Bell Rd Parton Rd PM (Site Folder: General)]

 Network: 2 [2063_Opt10D_PM (Network Folder: General)]

New Site
Site Category: (None)
Stop (Two-Way)

Site Layout

Layout pictures are schematic functional drawings reflecting input data. They are not design drawings.

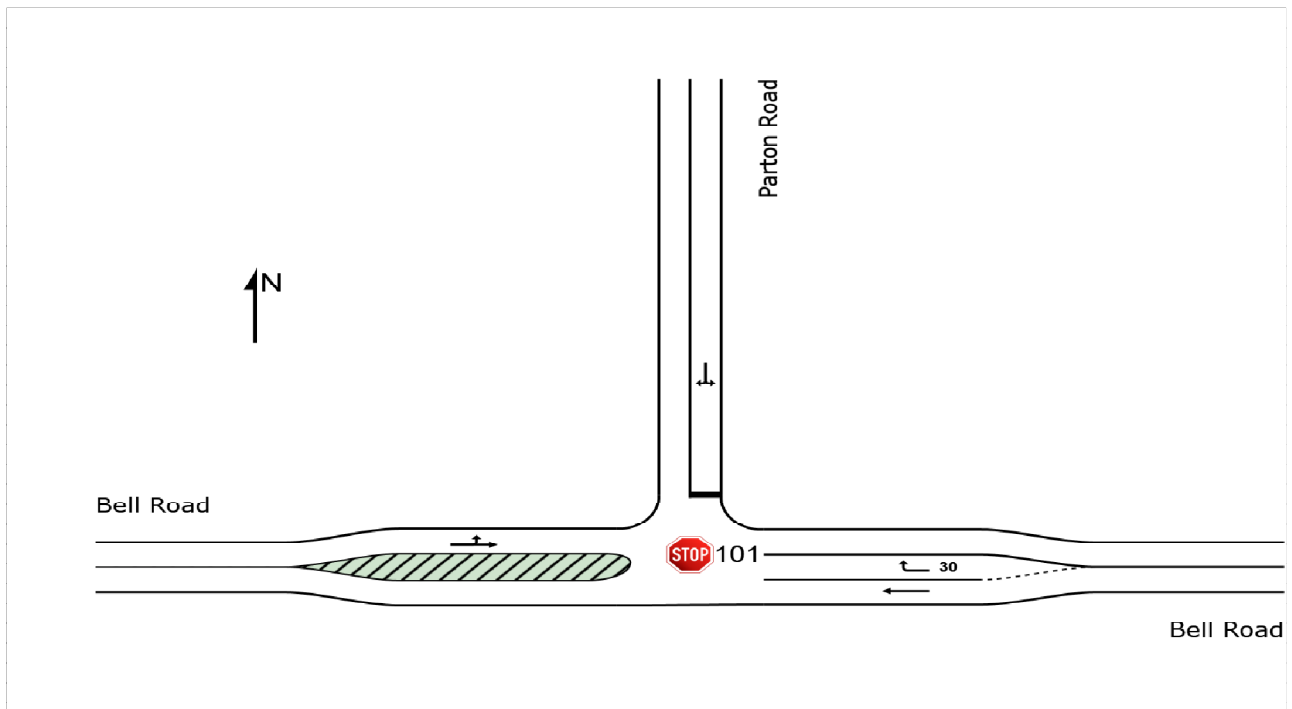

MOVEMENT SUMMARY

 Site: 101 [1348 Bell Rd Parton Rd PM (Site Folder: General)]

Output produced by SIDRA INTERSECTION Version: 9.1.6.228

 Network: N101
[2063_Opt10D_PM (Network Folder: General)]

New Site
Site Category: (None)
Stop (Two-Way)

Vehicle Movement Performance														
Mov ID	Turn	Mov Class	Demand Flows		Arrival Flows		Deg. Satn	Aver. Delay	Level of Service	Aver. Back Of Queue	Prop. Que	Eff. Stop Rate	Aver. No. of Cycles	Aver. Speed
			[Total HV] veh/h	%	[Total HV] veh/h	%								
East: Bell Road														
5	T1	All MCs	532	3.7	527	3.7	0.277	0.2	LOS A	0.0	0.0	0.00	0.00	99.8
6	R2	All MCs	213	3.7	211	3.7	0.203	10.0	LOS A	0.4	2.7	0.56	0.76	88.1
Approach			744	3.7	738	3.7	0.277	3.0	NA	0.4	2.7	0.16	0.22	95.8
North: Parton Road														
7	L2	All MCs	172	3.7	172	3.7	0.480	13.8	LOS B	1.2	8.5	0.70	1.02	55.4
9	R2	All MCs	143	3.7	143	3.7	0.480	19.8	LOS C	1.2	8.5	0.70	1.02	55.4
Approach			315	3.7	315	3.7	0.480	16.5	LOS C	1.2	8.5	0.70	1.02	55.4
West: Bell Road														
10	L2	All MCs	131	3.7	131	3.7	0.272	8.0	LOS A	0.0	0.0	0.00	0.17	83.9
11	T1	All MCs	380	3.7	380	3.7	0.272	0.0	LOS A	0.0	0.0	0.00	0.17	92.4
Approach			511	3.7	511	3.7	0.272	2.1	NA	0.0	0.0	0.00	0.17	89.1
All Vehicles			1569	3.7	1563	3.7	0.480	5.4	NA	1.2	8.5	0.22	0.36	90.8

Site Level of Service (LOS) Method: Delay (SIDRA). Site LOS Method is specified in the Network Data dialog (Override Site Data tab).

Vehicle movement LOS values are based on average delay per movement.

Minor Road Approach LOS values are based on average delay for all vehicle movements.

NA (TWSC): Level of Service is not defined for major road approaches or the intersection as a whole for Two-Way Sign Control (HCM LOS rule).

Two-Way Sign Control Capacity Model: SIDRA Standard.

Delay Model: SIDRA Standard (Control Delay: Geometric Delay is included).

Queue Model: SIDRA queue estimation methods are used for Back of Queue and Queue at Start of Gap.

Gap-Acceptance Capacity Formula: SIDRA Standard (Akçelik M3D).

HV (%) values are calculated for All Movement Classes of All Heavy Vehicle Model Designation.

Arrival Flows used in performance calculations are adjusted to include any Initial Queued Demand and Upstream Capacity Constraint effects.

SIDRA INTERSECTION 9.1 | Copyright © 2000-2024 Akcelik and Associates Pty Ltd | sidrasolutions.com

Organisation: BOFFA MISKELL | Licence: NETWORK / 1PC | Processed: Saturday, 28 March 2026 2:05:42 pm

Project: U:\2025\BM250088_BSa_Wairakei_South_Masterplan\Documents\Transport\Modelling\Sidra Network\260328 Sidra Models for ITA from Anna\2063_TTHM 10D Mitigated_v1.sip9

MOVEMENT SUMMARY

Site: 2140p [2140 Te Puke Hwy Bell Rd PM Signals (Site Folder: General)]

Output produced by SIDRA INTERSECTION Version: 9.1.6.228

Network: N101
[2063_Opt10D_PM (Network Folder: General)]

New Site

Site Category: (None)

Signals - EQUISAT (Fixed-Time/SCATS) Isolated Cycle Time = 50 seconds (Site Practical Cycle Time)

Vehicle Movement Performance															
Mov ID	Turn	Mov Class	Demand Flows		Arrival Flows		Deg. Satn	Aver. Delay	Level of Service	Aver. Back Of Queue [Veh. veh]	Prop. Que	Eff. Stop Rate	Aver. No. of Cycles	Aver. Speed km/h	
			[Total HV] veh/h	%	[Total HV] veh/h	%									
South: Te Puke Hwy															
2	T1	All MCs	653	4.5	653	4.5	0.638	8.8	LOS A	7.0	50.7	0.75	0.67	0.75	98.4
3	R2	All MCs	243	4.5	243	4.5	*0.845	36.8	LOS D	4.3	31.3	1.00	0.96	1.46	93.7
Approach			896	4.5	896	4.5	0.845	16.4	LOS B	7.0	50.7	0.82	0.75	0.94	97.1
East: Bell Road															
4	L2	All MCs	373	4.5	370	4.5	0.342	12.3	LOS B	2.2	16.2	0.54	0.75	0.54	96.9
6	R2	All MCs	312	4.5	309	4.5	*0.782	32.2	LOS C	5.1	36.7	1.00	0.91	1.25	52.9
Approach			684	4.5	680	4.5	0.782	21.4	LOS C	5.1	36.7	0.75	0.82	0.86	92.3
North: Te Puke Hwy															
7	L2	All MCs	268	4.5	268	4.5	0.220	10.8	LOS B	1.2	8.6	0.42	0.71	0.42	63.3
8	T1	All MCs	583	4.5	583	4.5	*0.794	21.2	LOS C	6.3	46.1	0.95	0.85	1.11	96.4
Approach			852	4.5	852	4.5	0.794	17.9	LOS B	6.3	46.1	0.78	0.81	0.89	95.6
All Vehicles			2432	4.5	2427	4.5	0.845	18.3	LOS B	7.0	50.7	0.79	0.79	0.90	95.6

Site Level of Service (LOS) Method: Delay (SIDRA). Site LOS Method is specified in the Network Data dialog (Override Site Data tab).

Vehicle movement LOS values are based on average delay per movement.

Intersection and Approach LOS values are based on average delay for all vehicle movements.

Delay Model: SIDRA Standard (Control Delay: Geometric Delay is included).

Queue Model: SIDRA queue estimation methods are used for Back of Queue and Queue at Start of Green.

Gap-Acceptance Capacity Formula: SIDRA Standard (Akçelik M3D).

HV (%) values are calculated for All Movement Classes of All Heavy Vehicle Model Designation.

Arrival Flows used in performance calculations are adjusted to include any Initial Queued Demand and Upstream Capacity Constraint effects.

* Critical Movement (Signal Timing)

SIDRA INTERSECTION 9.1 | Copyright © 2000-2024 Akcelik and Associates Pty Ltd | sidrasolutions.com

Organisation: AJW | Licence: NETWORK / 1PC | Processed: Friday, 27 March 2026 7:50:12 pm

Project: C:\Users\annaj\OneDrive\AW Consulting\Projects\Boffa Miskell Jobs\Wairakei South\ITA Work Feb 2026\Final SIDRA Modelling\Third Round Base Sidra File\2063_TTHM 10D Mitigated.sip9

MOVEMENT SUMMARY

Site: 99p [MIBA Internal Roundabout PM (Site Folder: General)]

Output produced by SIDRA INTERSECTION Version: 9.1.6.228

Network: N101
[2063_Opt10D_PM (Network Folder: General)]

New Site
Site Category: (None)
Roundabout

Vehicle Movement Performance															
Mov ID	Turn	Mov Class	Demand Flows		Arrival Flows		Deg. Satn	Aver. Delay	Level of Service	Aver. Back Of Queue		Prop. Que	Eff. Stop Rate	Aver. No. of Cycles	Aver. Speed
			[Total HV] veh/h	%	[Total HV] veh/h	%				[Veh. veh	[Dist] m				
South: Internal Road South															
1	L2	All MCs	166	5.0	166	5.0	0.207	4.8	LOSA	0.5	3.3	0.38	0.54	0.38	43.2
2	T1	All MCs	1	5.0	1	5.0	0.207	4.7	LOSA	0.5	3.3	0.38	0.54	0.38	45.6
3	R2	All MCs	58	5.0	58	5.0	0.207	7.9	LOSA	0.5	3.3	0.38	0.54	0.38	43.2
Approach			225	5.0	225	5.0	0.207	5.6	LOSA	0.5	3.3	0.38	0.54	0.38	43.2
East: Latham Drive East															
4	L2	All MCs	67	5.0	67	5.0	0.137	4.5	LOSA	0.3	2.1	0.31	0.51	0.31	43.8
5	T1	All MCs	53	5.0	53	5.0	0.137	4.4	LOSA	0.3	2.1	0.31	0.51	0.31	36.9
6	R2	All MCs	34	5.0	34	5.0	0.137	7.6	LOSA	0.3	2.1	0.31	0.51	0.31	43.4
Approach			154	5.0	154	5.0	0.137	5.1	LOSA	0.3	2.1	0.31	0.51	0.31	42.6
North: Internal Road North															
7	L2	All MCs	114	5.0	114	5.0	0.175	4.7	LOSA	0.4	2.8	0.35	0.55	0.35	43.3
8	T1	All MCs	1	5.0	1	5.0	0.175	4.6	LOSA	0.4	2.8	0.35	0.55	0.35	45.4
9	R2	All MCs	77	5.0	77	5.0	0.175	7.8	LOSA	0.4	2.8	0.35	0.55	0.35	42.9
Approach			192	5.0	192	5.0	0.175	6.0	LOSA	0.4	2.8	0.35	0.55	0.35	43.2
West: Latham Drive West															
10	L2	All MCs	65	5.0	62	5.0	0.134	4.3	LOSA	0.3	1.9	0.25	0.52	0.25	42.8
11	T1	All MCs	53	5.0	50	5.0	0.134	4.1	LOSA	0.3	1.9	0.25	0.52	0.25	38.0
12	R2	All MCs	47	5.0	45	5.0	0.134	7.4	LOSA	0.3	1.9	0.25	0.52	0.25	42.4
Approach			165	5.0	158	5.0	0.134	5.1	LOSA	0.3	1.9	0.25	0.52	0.25	41.7
All Vehicles			736	5.0	728	5.1	0.207	5.5	LOSA	0.5	3.3	0.33	0.53	0.33	42.8

Site Level of Service (LOS) Method: Delay (SIDRA). Site LOS Method is specified in the Network Data dialog (Override Site Data tab).

Roundabout LOS Method: SIDRA Roundabout LOS.

Vehicle movement LOS values are based on average delay per movement.

Intersection and Approach LOS values are based on average delay for all vehicle movements.

Roundabout Capacity Model: SIDRA Standard.

Delay Model: SIDRA Standard (Control Delay: Geometric Delay is included).

Queue Model: SIDRA queue estimation methods are used for Back of Queue and Queue at Start of Gap.

Gap-Acceptance Capacity Formula: SIDRA Standard (Akçelik M3D).

HV (%) values are calculated for All Movement Classes of All Heavy Vehicle Model Designation.

Arrival Flows used in performance calculations are adjusted to include any Initial Queued Demand and Upstream Capacity Constraint effects.

SIDRA INTERSECTION 9.1 | Copyright © 2000-2024 Akcelik and Associates Pty Ltd | sidrasolutions.com

Organisation: AJW | Licence: NETWORK / 1PC | Processed: Friday, 27 March 2026 7:50:12 pm

Project: C:\Users\annaj\OneDrive\AW Consulting\Projects\Boffa Miskell Jobs\Wairakei South\ITA Work Feb 2026\Final SIDRA Modelling\Third Round Base Sidra File\2063_TTHM 10D Mitigated.sip9

PHASING SUMMARY

Site: 2859p [2859 Boulv_TheSand_PM (Site Folder: General)]

Output produced by SIDRA INTERSECTION Version: 9.1.6.228

Network: N101
[2063_Opt10D_PM (Network Folder: General)]

Site Category: (None)

Signals - EQUISAT (Fixed-Time/SCATS) Coordinated Cycle Time = 100 seconds (Network Optimum Cycle Time - Minimum Delay)

Timings based on settings in the Network Timing dialog

Phase Times determined by the program

Downstream lane blockage effects included in determining phase times

Green Split Priority has been specified

Phase Sequence: DDO - Copy

Input Phase Sequence: A, B*, D, D1*, E, F, F1*, C*

Output Phase Sequence: A, B*, D, D1*, E, F, F1*

Reference Phase: Phase A

Offset: 57 seconds (Program)

(* Variable Phase)

Phase Timing Summary

Phase	A	B	D	D1	E	F	F1
Phase Change Time (sec)	62	84	96	8	30	42	54
Green Time (sec)	21	6	6	16	6	6	2
Phase Time (sec)	27	12	12	22	12	12	3
Phase Split	27%	12%	12%	22%	12%	12%	3%
Phase Frequency (%)	100.0	100.0	100.0	100.0	100.0	100.0	12.3 ³

See the Timing Analysis report for more detailed information including input values of Yellow Time and All-Red Time, and information on any adjustments to Intergreen Time, Phase Time and Green Time values in cases of Pedestrian Actuation, Minor Phase Actuation and Phase Frequency values (user-specified or implied) less than 100%.

³ Phase Frequency has been estimated from actuated movement probabilities.

Output Phase Sequence

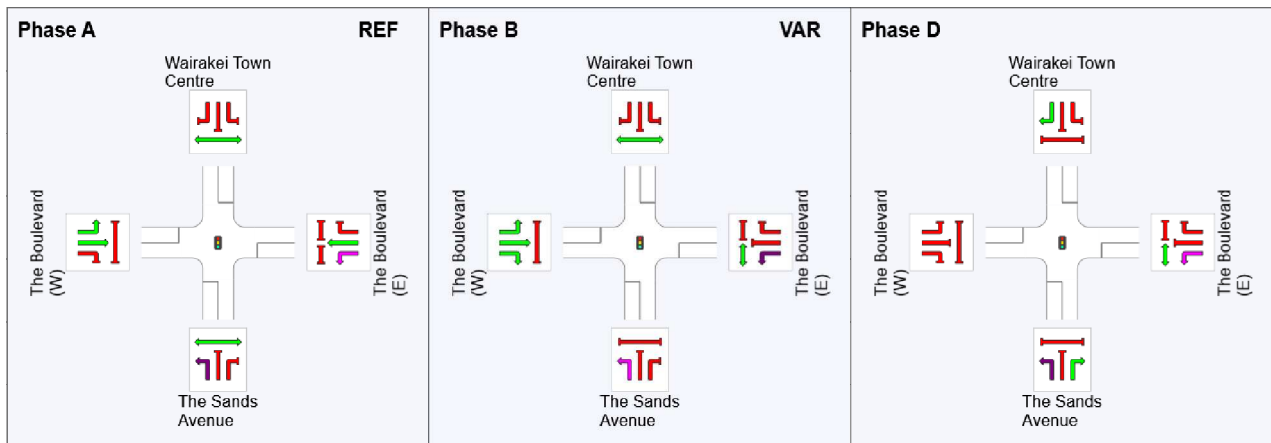

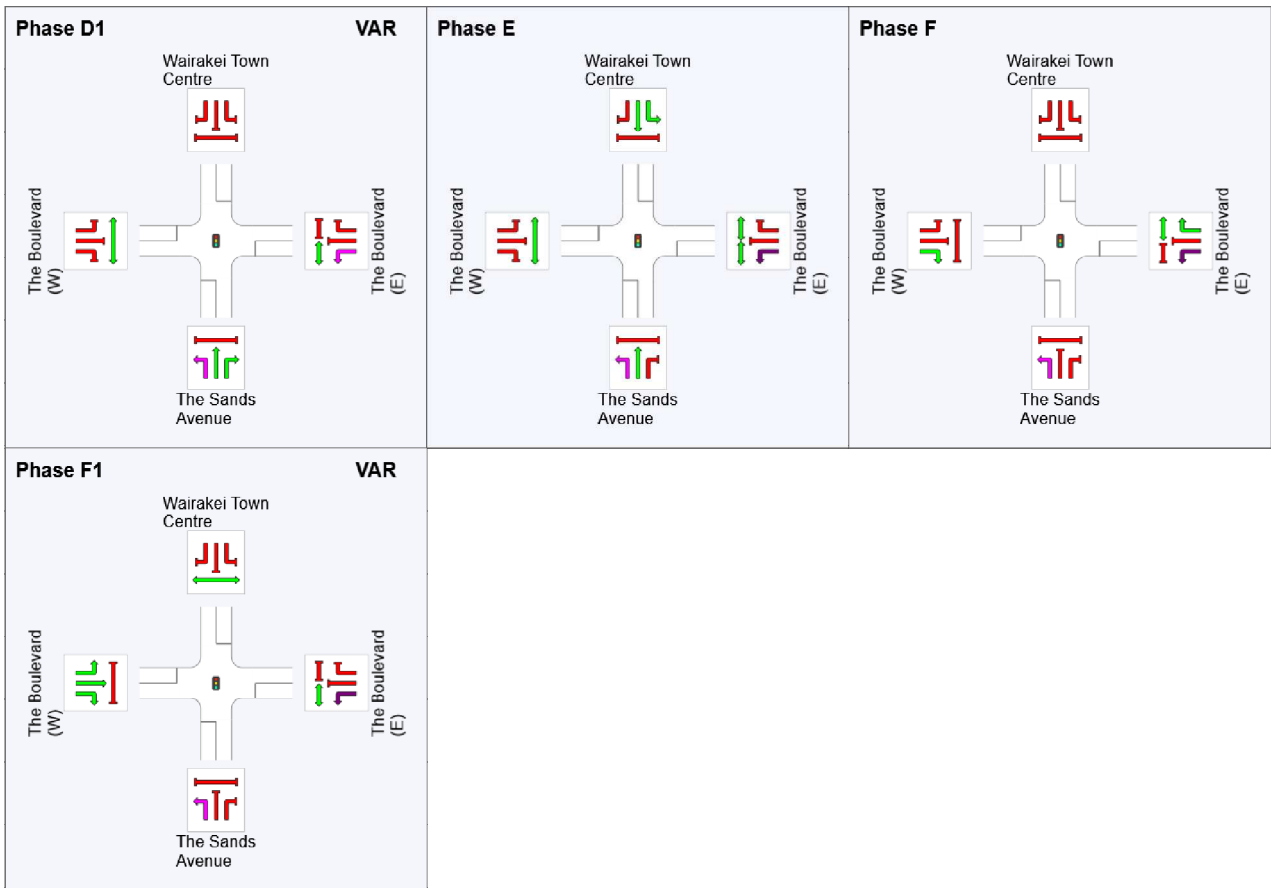

REF: Reference Phase
 VAR: Variable Phase

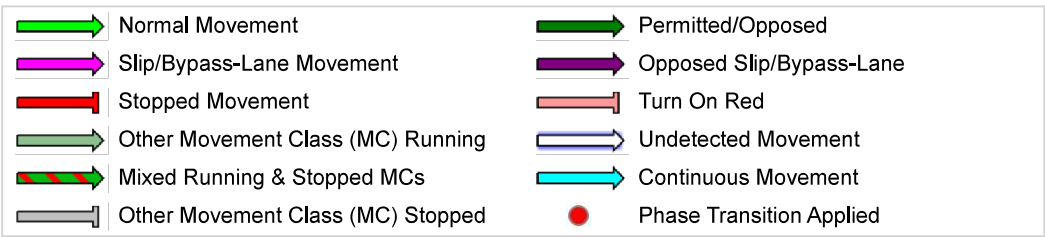

PHASING SUMMARY

Site: 2860p [2860 The Sand_Bill Miller_PM (Site Folder: General)]

Output produced by SIDRA INTERSECTION Version: 9.1.6.228

Network: N101
[2063_Opt10D_PM (Network Folder: General)]

Site Category: (None)

Signals - EQUISAT (Fixed-Time/SCATS) Coordinated Cycle Time = 100 seconds (Network Optimum Cycle Time - Minimum Delay)

Timings based on settings in the Network Timing dialog

Phase Times determined by the program

Downstream lane blockage effects included in determining phase times

Green Split Priority has been specified

Phase Sequence: DDO - Copy

Input Phase Sequence: A, D, E, F

Output Phase Sequence: A, D, E, F

Reference Phase: Phase A

Offset: 90 seconds (Program)

Phase Timing Summary

Phase	A	D	E	F
Phase Change Time (sec)	90	53	73	78
Green Time (sec)	57	14	***	6
Phase Time (sec)	63	20	5	12
Phase Split	63%	20%	5%	12%
Phase Frequency (%)	100.0	100.0	100.0	100.0

See the Timing Analysis report for more detailed information including input values of Yellow Time and All-Red Time, and information on any adjustments to Intergreen Time, Phase Time and Green Time values in cases of Pedestrian Actuation, Minor Phase Actuation and Phase Frequency values (user-specified or implied) less than 100%.

Output Phase Sequence

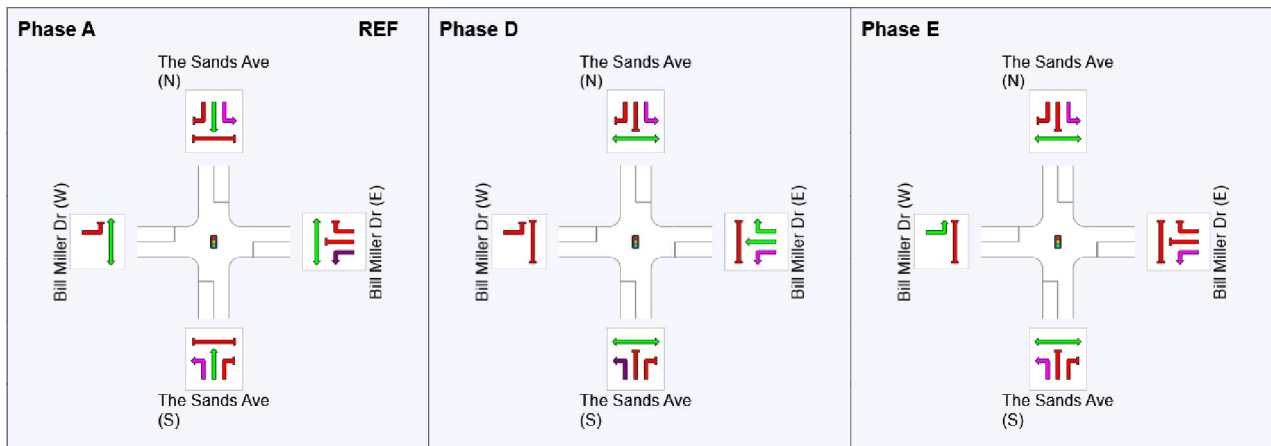

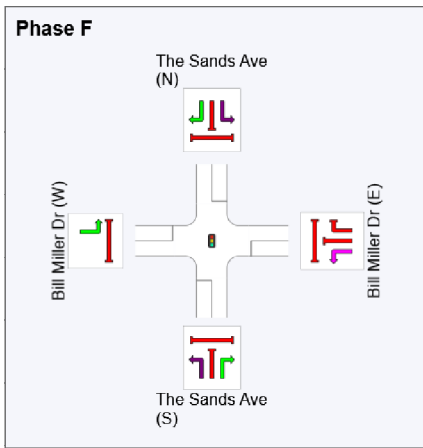

REF: Reference Phase

VAR: Variable Phase



SIDRA INTERSECTION 9.1 | Copyright © 2000-2024 Kcelik and Associates Pty Ltd | sidrasolutions.com

Organisation: AJW | Licence: NETWORK / 1PC | Processed: Friday, 27 March 2026 7:50:12 pm

Project: C:\Users\annaj\OneDrive\AW Consulting\Projects\Boffa Miskell Jobs\Wairakei South\ITA Work Feb 2026\Final SIDRA Modelling\Third Round Base Sidra File\2063_TTHM 10D Mitigated.sip9

PHASING SUMMARY

Site: 2514p [2514 Sands_Te Okuroa_PM (Site Folder: General)]

Output produced by SIDRA INTERSECTION Version: 9.1.6.228

Network: N101
[2063_Opt10D_PM (Network Folder: General)]

Site Category: (None)

Signals - EQUISAT (Fixed-Time/SCATS) Coordinated Cycle Time = 100 seconds (Network Optimum Cycle Time - Minimum Delay)

Timings based on settings in the Network Timing dialog

Phase Times determined by the program

Downstream lane blockage effects included in determining phase times

Green Split Priority has been specified

Phase Sequence: Variable Phasing

Input Phase Sequence: A, D, E, F, G

Output Phase Sequence: A, D, E, F, G

Reference Phase: Phase A

Offset: 87 seconds (Program)

Phase Timing Summary

Phase	A	D	E	F	G
Phase Change Time (sec)	87	19	41	65	77
Green Time (sec)	26	16	18	6	4
Phase Time (sec)	32	22	24	12	10
Phase Split	32%	22%	24%	12%	10%
Phase Frequency (%)	100.0	100.0	100.0	100.0	100.0

See the Timing Analysis report for more detailed information including input values of Yellow Time and All-Red Time, and information on any adjustments to Intergreen Time, Phase Time and Green Time values in cases of Pedestrian Actuation, Minor Phase Actuation and Phase Frequency values (user-specified or implied) less than 100%.

Output Phase Sequence

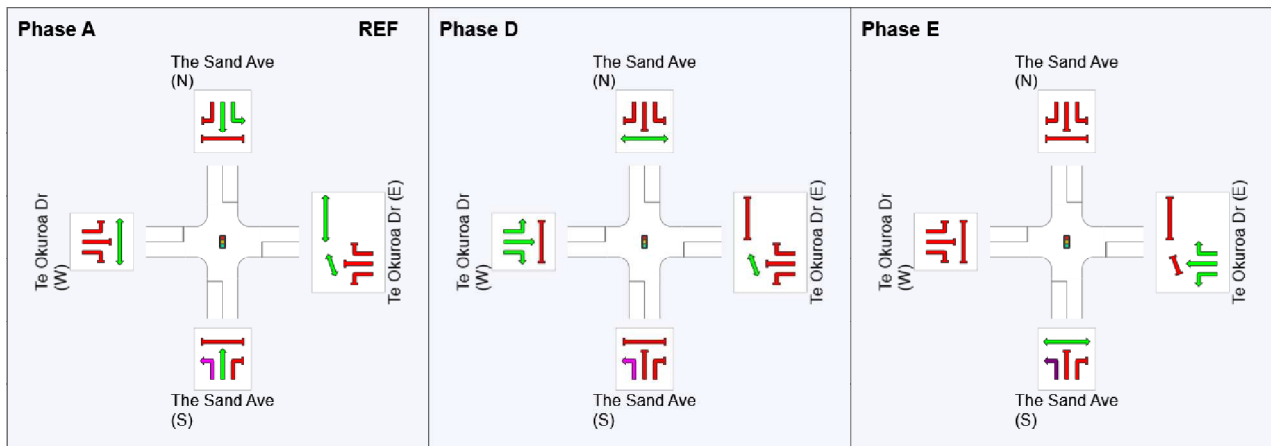

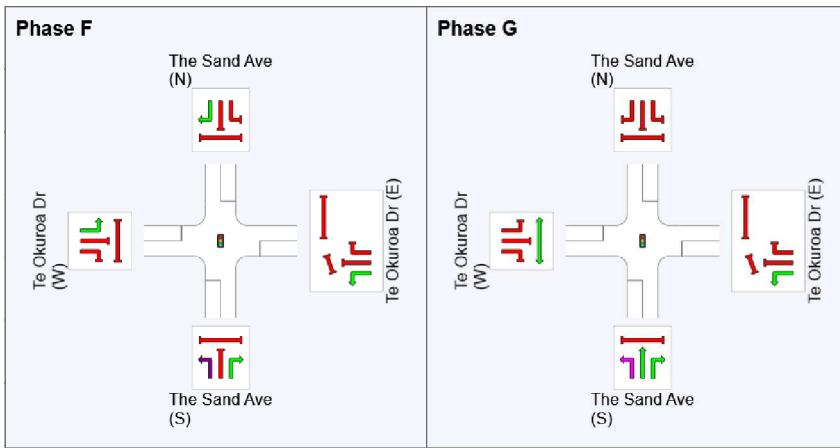

REF: Reference Phase
 VAR: Variable Phase

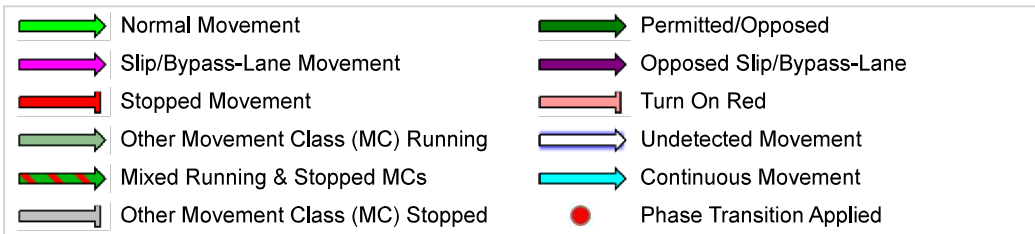

SIDRA INTERSECTION 9.1 | Copyright © 2000-2024 Kcelik and Associates Pty Ltd | sidrasolutions.com

Organisation: AJW | Licence: NETWORK / 1PC | Processed: Friday, 27 March 2026 7:50:12 pm

Project: C:\Users\annaj\OneDrive\AW Consulting\Projects\Boffa Miskell Jobs\Wairakei South\ITA Work Feb 2026\Final SIDRA Modelling\Third Round Base Sidra File\2063_TTHM 10D Mitigated.sip9

PHASING SUMMARY

Site: 10003p [10003_PM (Site Folder: General)]

Output produced by SIDRA INTERSECTION Version: 9.1.6.228

Network: N101
[2063_Opt10D_PM (Network Folder: General)]

NA

Site Category: (None)

Signals - EQUISAT (Fixed-Time/SCATS) Isolated Cycle Time = 120 seconds (Site Practical Cycle Time)

Timings based on settings in the Site Phasing & Timing dialog

Phase Times determined by the program

Downstream lane blockage effects included in determining phase times

Green Split Priority has been specified

Phase Sequence: Four-Phase Split Phasing

Input Phase Sequence: A, B, C, D

Output Phase Sequence: A, B, C, D

Reference Phase: Phase A

Offset: 0 seconds (User)

Phase Timing Summary







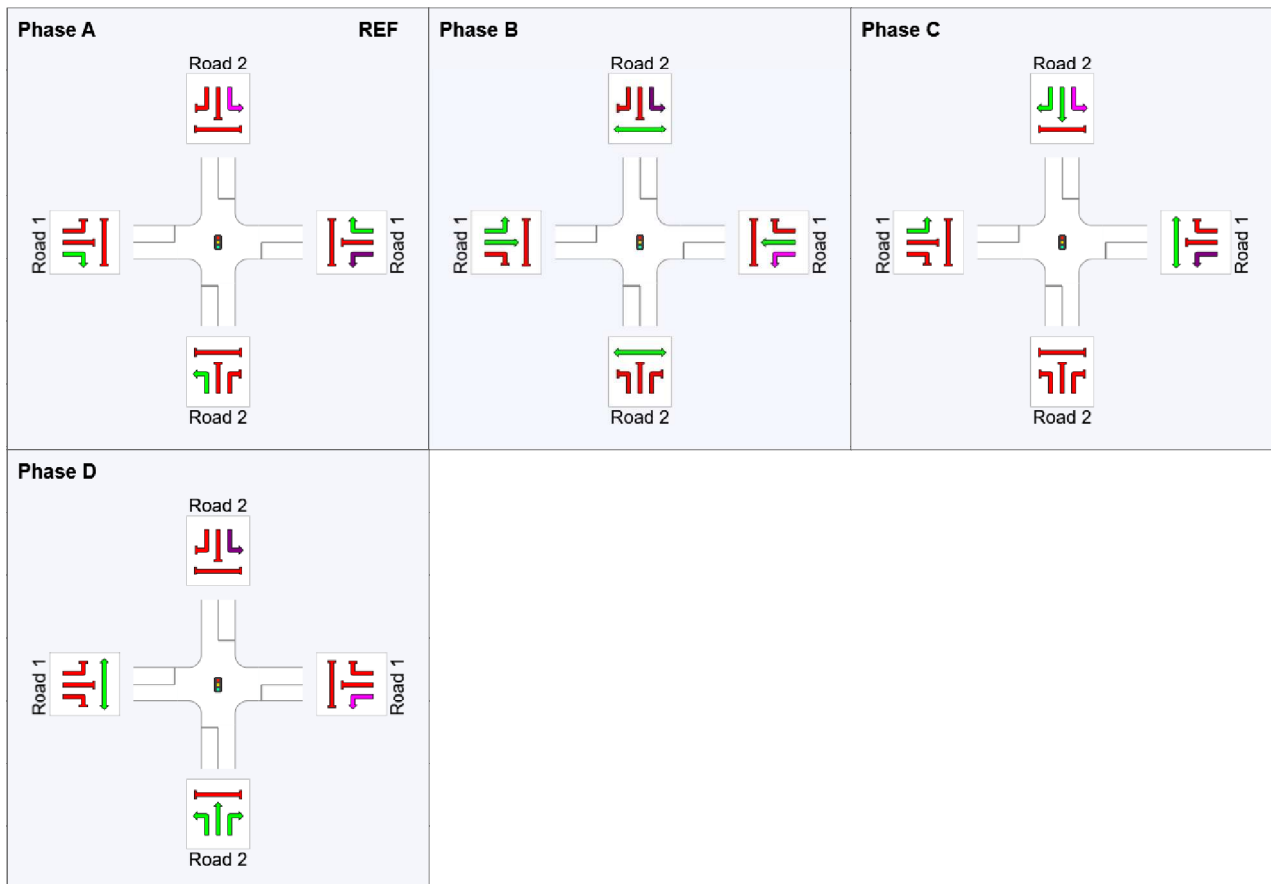





Phase	A	B	C	D
Phase Change Time (sec)	0	12	62	83
Green Time (sec)	6	44	15	31
Phase Time (sec)	12	50	21	37
Phase Split	10%	42%	18%	31%
Phase Frequency (%)	100.0	100.0	100.0	100.0

See the Timing Analysis report for more detailed information including input values of Yellow Time and All-Red Time, and information on any adjustments to Intergreen Time, Phase Time and Green Time values in cases of Pedestrian Actuation, Minor Phase Actuation and Phase Frequency values (user-specified or implied) less than 100%.

Output Phase Sequence



REF: Reference Phase
VAR: Variable Phase

	Normal Movement		Permitted/Opposed
	Slip/Bypass-Lane Movement		Opposed Slip/Bypass-Lane
	Stopped Movement		Turn On Red
	Other Movement Class (MC) Running		Undetected Movement
	Mixed Running & Stopped MCs		Continuous Movement
	Other Movement Class (MC) Stopped		Phase Transition Applied

SIDRA INTERSECTION 9.1 | Copyright © 2000-2024 Akcelik and Associates Pty Ltd | sidrasolutions.com

Organisation: AJW | Licence: NETWORK / 1PC | Processed: Friday, 27 March 2026 7:50:12 pm

Project: C:\Users\anna\OneDrive\AW Consulting\Projects\Boffa Miskell Jobs\Wairakei South\ITA Work Feb 2026\Final SIDRA Modelling\Third Round Base Sidra File\2063_TTHM 10D Mitigated.sip9

PHASING SUMMARY

Site: 10007p [10007_PM (Site Folder: General)]

Output produced by SIDRA INTERSECTION Version: 9.1.6.228

Network: N101
[2063_Opt10D_PM (Network Folder: General)]

NA

Site Category: (None)

Signals - EQUISAT (Fixed-Time/SCATS) Isolated Cycle Time = 70 seconds (Site Practical Cycle Time)

Timings based on settings in the Site Phasing & Timing dialog

Phase Times determined by the program

Downstream lane blockage effects included in determining phase times

Phase Sequence: Four-Phase Leading Right Turns

Input Phase Sequence: A, B, C, D

Output Phase Sequence: A, B, C, D

Reference Phase: Phase B

Offset: 0 seconds (User)

Phase Timing Summary







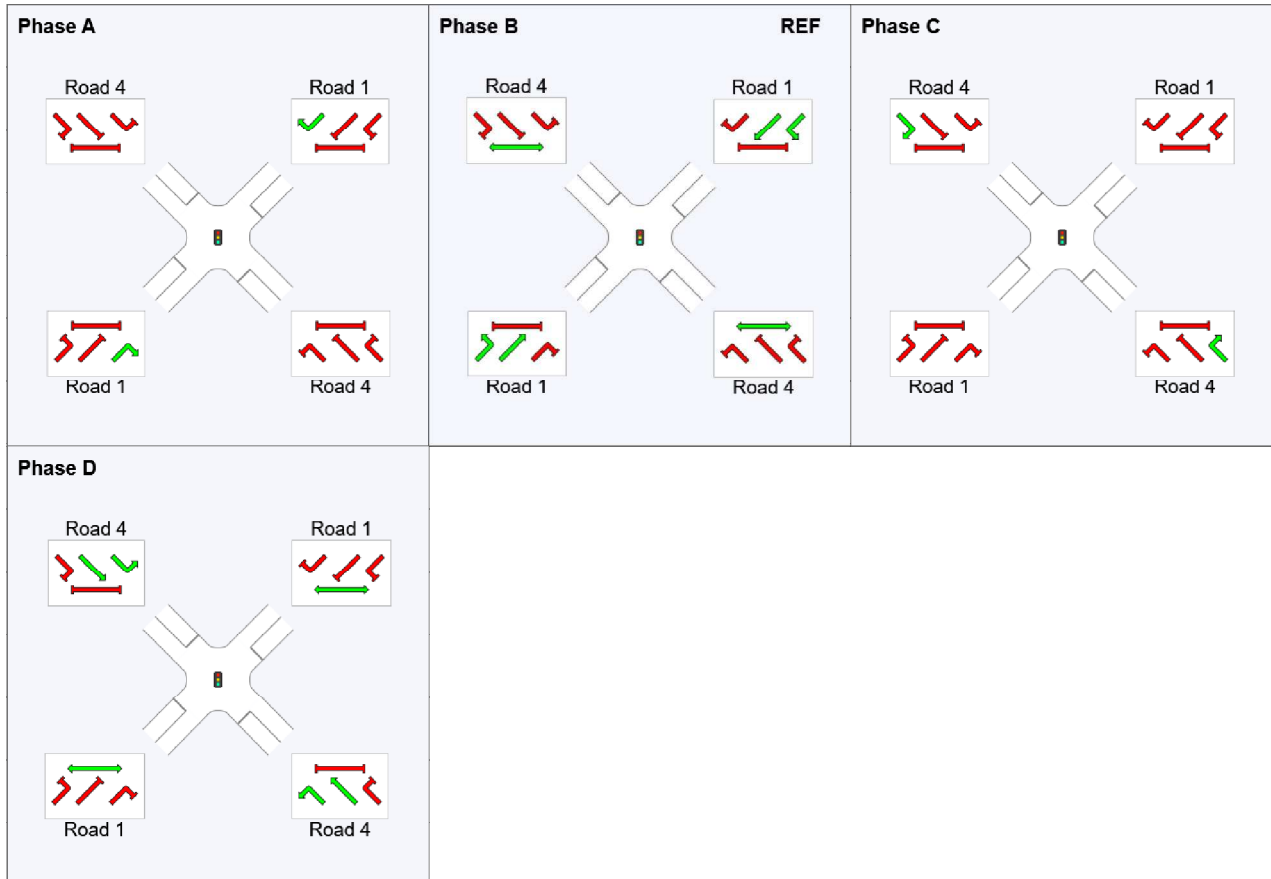





Phase	A	B	C	D
Phase Change Time (sec)	54	0	17	29
Green Time (sec)	10	11	6	19
Phase Time (sec)	16	17	12	25
Phase Split	23%	24%	17%	36%
Phase Frequency (%)	100.0	100.0	100.0	100.0

See the Timing Analysis report for more detailed information including input values of Yellow Time and All-Red Time, and information on any adjustments to Intergreen Time, Phase Time and Green Time values in cases of Pedestrian Actuation, Minor Phase Actuation and Phase Frequency values (user-specified or implied) less than 100%.

Output Phase Sequence



REF: Reference Phase
VAR: Variable Phase

	Normal Movement		Permitted/Opposed
	Slip/Bypass-Lane Movement		Opposed Slip/Bypass-Lane
	Stopped Movement		Turn On Red
	Other Movement Class (MC) Running		Undetected Movement
	Mixed Running & Stopped MCs		Continuous Movement
	Other Movement Class (MC) Stopped		Phase Transition Applied

SIDRA INTERSECTION 9.1 | Copyright © 2000-2024 Kcelik and Associates Pty Ltd | sidrasolutions.com

Organisation: AJW | Licence: NETWORK / 1PC | Processed: Friday, 27 March 2026 7:50:12 pm

Project: C:\Users\lannaj\OneDrive\AW Consulting\Projects\Boffa Miskell Jobs\Wairakei South\ITA Work Feb 2026\Final SIDRA Modelling\Third Round Base Sidra File\2063_TTHM 10D Mitigated.sip9

PHASING SUMMARY

Site: 10008p [10008_PM (Site Folder: General)]

Output produced by SIDRA INTERSECTION Version: 9.1.6.228

Network: N101
[2063_Opt10D_PM (Network Folder: General)]

New Site

Site Category: (None)

Signals - EQUISAT (Fixed-Time/SCATS) Isolated Cycle Time = 70 seconds (Site Practical Cycle Time)

Timings based on settings in the Site Phasing & Timing dialog

Phase Times determined by the program

Downstream lane blockage effects included in determining phase times

Phase Sequence: Four-Phase Leading Right Turns

Input Phase Sequence: A, B, C, D

Output Phase Sequence: A, B, C, D

Reference Phase: Phase B

Offset: 0 seconds (User)

Phase Timing Summary







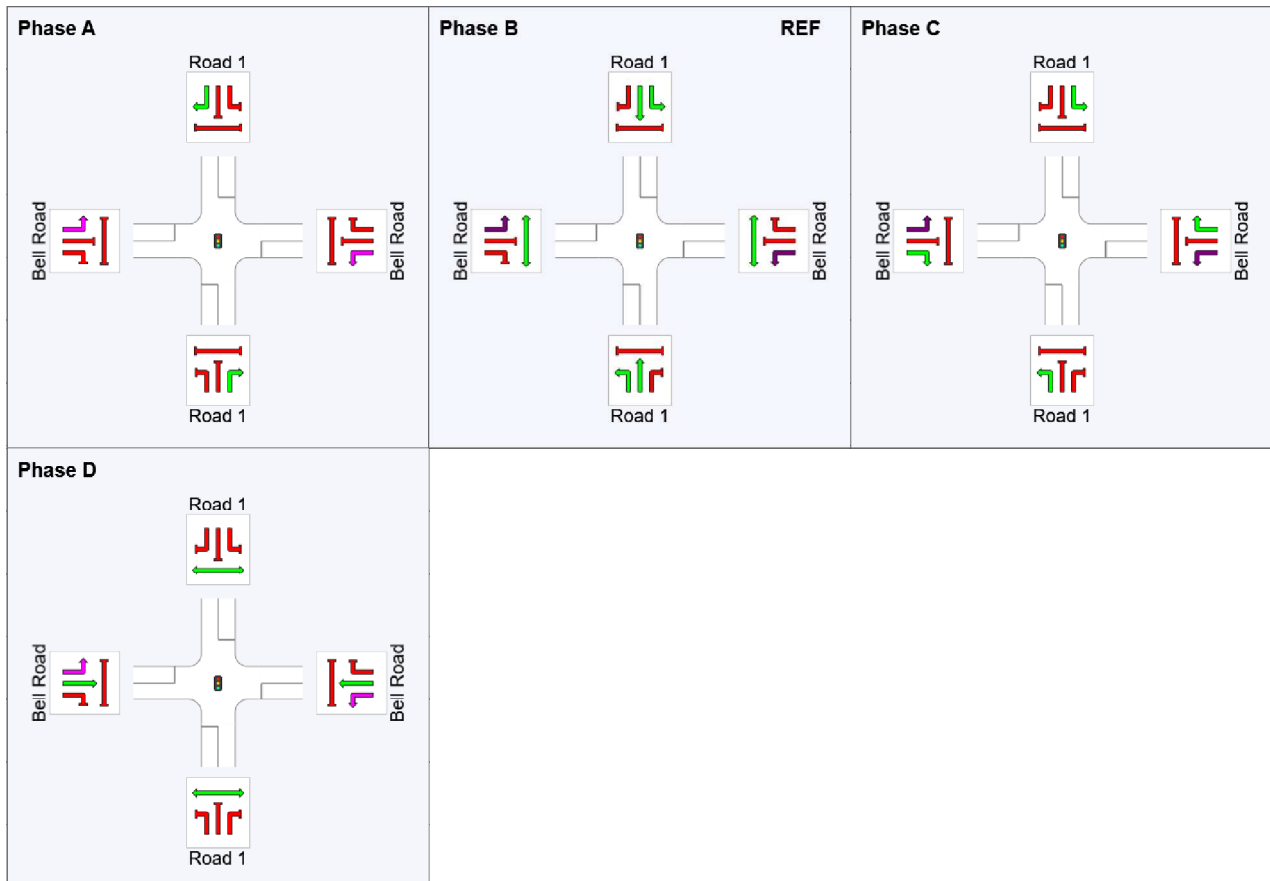





Phase	A	B	C	D
Phase Change Time (sec)	52	0	17	29
Green Time (sec)	12	11	6	17
Phase Time (sec)	18	17	12	23
Phase Split	26%	24%	17%	33%
Phase Frequency (%)	100.0	100.0	100.0	100.0

See the Timing Analysis report for more detailed information including input values of Yellow Time and All-Red Time, and information on any adjustments to Intergreen Time, Phase Time and Green Time values in cases of Pedestrian Actuation, Minor Phase Actuation and Phase Frequency values (user-specified or implied) less than 100%.

Output Phase Sequence



REF: Reference Phase
VAR: Variable Phase

	Normal Movement		Permitted/Opposed
	Slip/Bypass-Lane Movement		Opposed Slip/Bypass-Lane
	Stopped Movement		Turn On Red
	Other Movement Class (MC) Running		Undetected Movement
	Mixed Running & Stopped MCs		Continuous Movement
	Other Movement Class (MC) Stopped		Phase Transition Applied

SIDRA INTERSECTION 9.1 | Copyright © 2000-2024 Kcelik and Associates Pty Ltd | sidrasolutions.com

Organisation: AJW | Licence: NETWORK / 1PC | Processed: Friday, 27 March 2026 7:50:12 pm

Project: C:\Users\lannaj\OneDrive\AW Consulting\Projects\Boffa Miskell Jobs\Wairakei South\ITA Work Feb 2026\Final SIDRA Modelling\Third Round Base Sidra File\2063_TTHM 10D Mitigated.sip9

PHASING SUMMARY

Site: 10015p [10015_PM (Site Folder: General)]

Output produced by SIDRA INTERSECTION Version: 9.1.6.228

Network: N101
[2063_Opt10D_PM (Network Folder: General)]

New Site

Site Category: (None)

Signals - EQUISAT (Fixed-Time/SCATS) Isolated Cycle Time = 70 seconds (Site Practical Cycle Time)

Timings based on settings in the Site Phasing & Timing dialog

Phase Times determined by the program

Downstream lane blockage effects included in determining phase times

Phase Sequence: Four-Phase Leading Right Turns

Input Phase Sequence: A, B, C, D

Output Phase Sequence: A, B, C, D

Reference Phase: Phase B

Offset: 0 seconds (User)

Phase Timing Summary



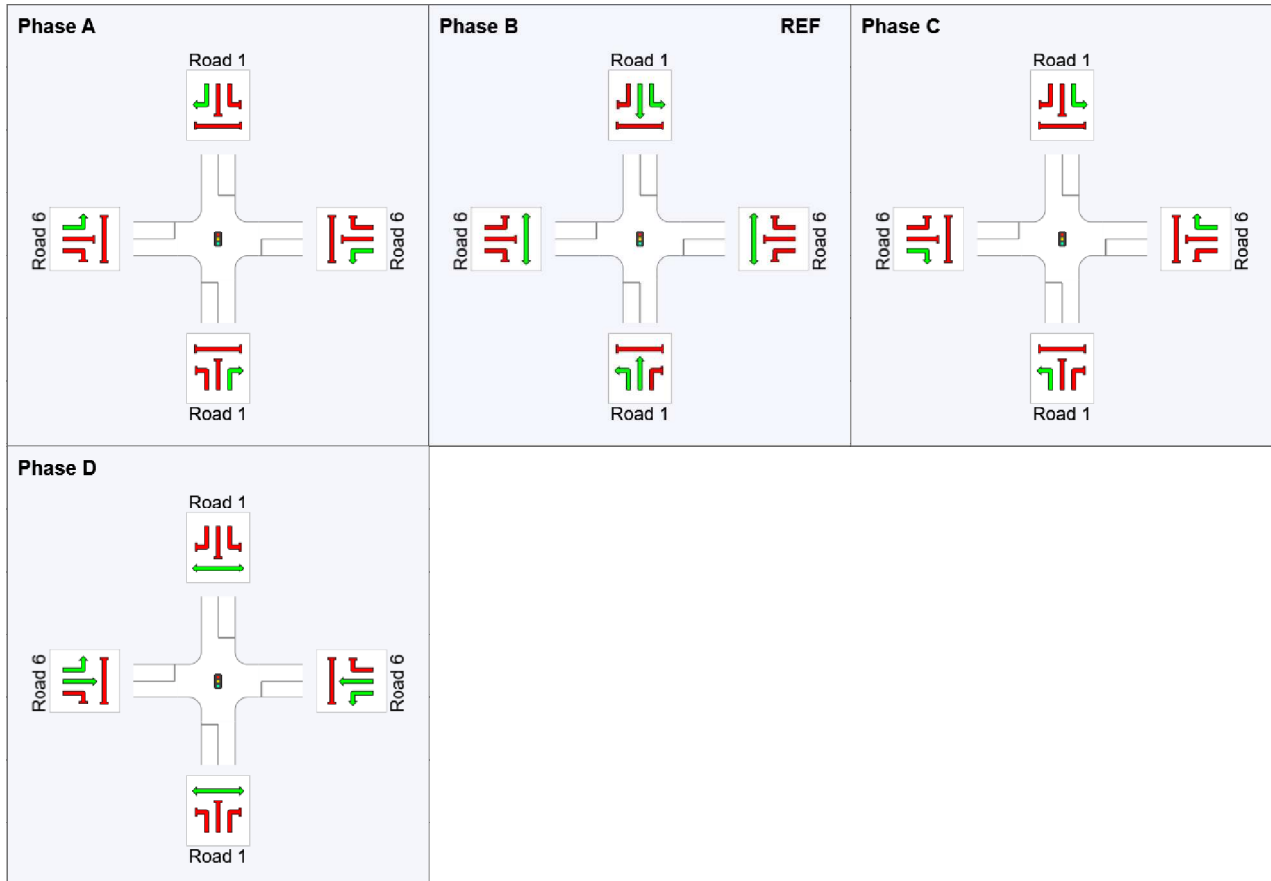

Phase	A	B	C	D
Phase Change Time (sec)	52	0	17	29
Green Time (sec)	12	11	6	17
Phase Time (sec)	18	17	12	23
Phase Split	26%	24%	17%	33%
Phase Frequency (%)	100.0	100.0	100.0	100.0

See the Timing Analysis report for more detailed information including input values of Yellow Time and All-Red Time, and information on any adjustments to Intergreen Time, Phase Time and Green Time values in cases of Pedestrian Actuation, Minor Phase Actuation and Phase Frequency values (user-specified or implied) less than 100%.

Output Phase Sequence



REF: Reference Phase
VAR: Variable Phase

	Normal Movement		Permitted/Opposed
	Slip/Bypass-Lane Movement		Opposed Slip/Bypass-Lane
	Stopped Movement		Turn On Red
	Other Movement Class (MC) Running		Undetected Movement
	Mixed Running & Stopped MCs		Continuous Movement
	Other Movement Class (MC) Stopped		Phase Transition Applied

SIDRA INTERSECTION 9.1 | Copyright © 2000-2024 Kcelik and Associates Pty Ltd | sidrasolutions.com

Organisation: AJW | Licence: NETWORK / 1PC | Processed: Friday, 27 March 2026 7:50:12 pm

Project: C:\Users\lannaj\OneDrive\AW Consulting\Projects\Boffa Miskell Jobs\Wairakei South\ITA Work Feb 2026\Final SIDRA Modelling\Third Round Base Sidra File\2063_TTHM 10D Mitigated.sip9

PHASING SUMMARY

Site: 10016p [10016_PM (Site Folder: General)]

Output produced by SIDRA INTERSECTION Version: 9.1.6.228

Network: N101
[2063_Opt10D_PM (Network Folder: General)]

New Site

Site Category: (None)

Signals - EQUISAT (Fixed-Time/SCATS) Isolated Cycle Time = 60 seconds (Site Practical Cycle Time)

Timings based on settings in the Site Phasing & Timing dialog

Phase Times determined by the program

Downstream lane blockage effects included in determining phase times

Phase Sequence: Four-Phase Leading Right Turns

Input Phase Sequence: A, B, C, D

Output Phase Sequence: A, B, C, D

Reference Phase: Phase B

Offset: 0 seconds (User)

Phase Timing Summary







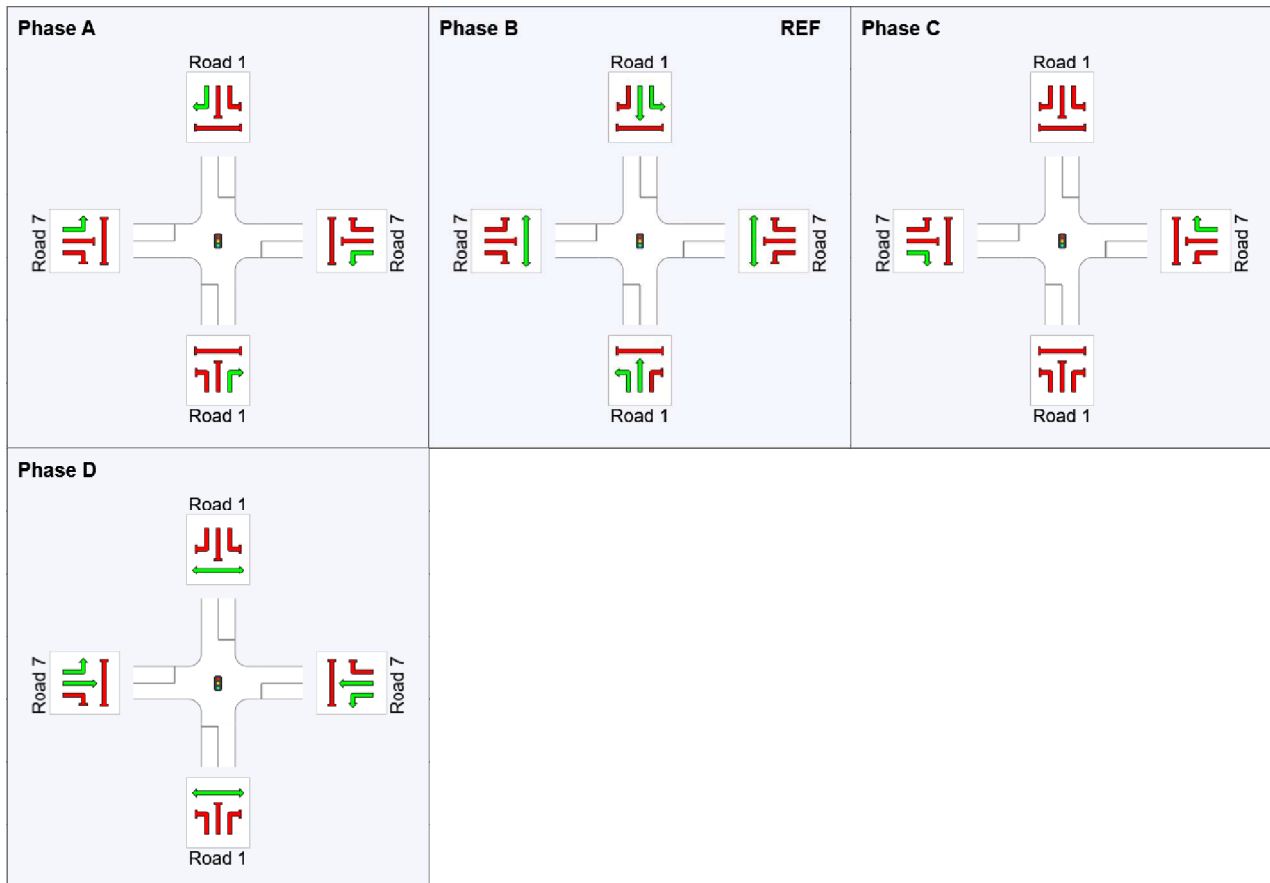



Phase	A	B	C	D
Phase Change Time (sec)	46	0	17	29
Green Time (sec)	8	11	6	11
Phase Time (sec)	14	17	12	17
Phase Split	23%	28%	20%	28%
Phase Frequency (%)	100.0	100.0	100.0	100.0

See the Timing Analysis report for more detailed information including input values of Yellow Time and All-Red Time, and information on any adjustments to Intergreen Time, Phase Time and Green Time values in cases of Pedestrian Actuation, Minor Phase Actuation and Phase Frequency values (user-specified or implied) less than 100%.

Output Phase Sequence



REF: Reference Phase
VAR: Variable Phase

	Normal Movement		Permitted/Opposed
	Slip/Bypass-Lane Movement		Opposed Slip/Bypass-Lane
	Stopped Movement		Turn On Red
	Other Movement Class (MC) Running		Undetected Movement
	Mixed Running & Stopped MCs		Continuous Movement
	Other Movement Class (MC) Stopped		Phase Transition Applied

PHASING SUMMARY

Site: 2140p [2140 Te Puke Hwy Bell Rd PM Signals (Site Folder: General)]

Output produced by SIDRA INTERSECTION Version: 9.1.6.228

Network: N101
[2063_Opt10D_PM (Network Folder: General)]

New Site
Site Category: (None)
Signals - EQUISAT (Fixed-Time/SCATS) Isolated Cycle Time = 50 seconds (Site Practical Cycle Time)

Timings based on settings in the Site Phasing & Timing dialog
Phase Times determined by the program
Downstream lane blockage effects included in determining phase times
Phase Sequence: Convert Function Default
Input Phase Sequence: A, B, C
Output Phase Sequence: A, B, C
Reference Phase: Phase B
Offset: 0 seconds (User)

Phase Timing Summary

Phase	A	B	C
Phase Change Time (sec)	36	0	19
Green Time (sec)	8	13	11
Phase Time (sec)	14	19	17
Phase Split	28%	38%	34%
Phase Frequency (%)	100.0	100.0	100.0

See the Timing Analysis report for more detailed information including input values of Yellow Time and All-Red Time, and information on any adjustments to Intergreen Time, Phase Time and Green Time values in cases of Pedestrian Actuation, Minor Phase Actuation and Phase Frequency values (user-specified or implied) less than 100%.

Output Phase Sequence

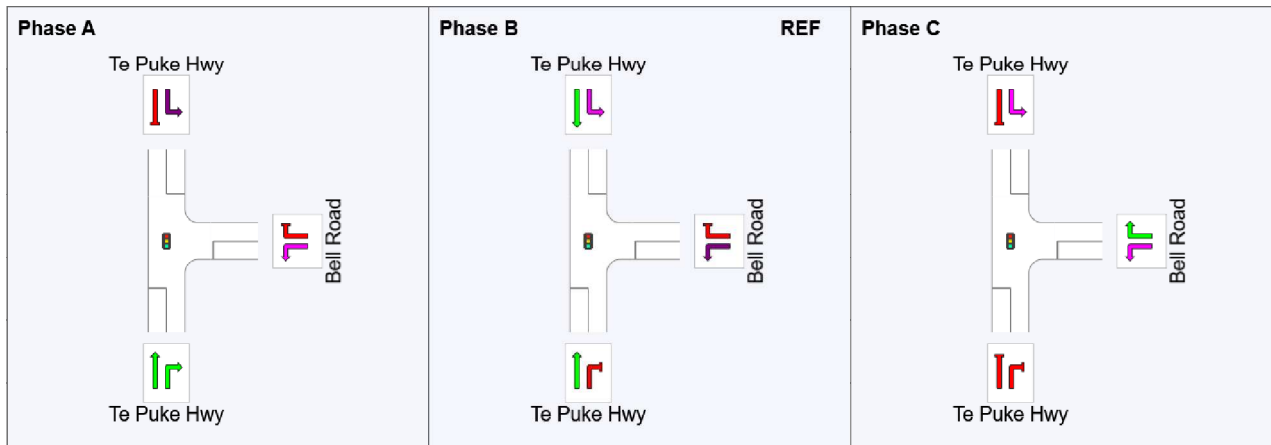

REF: Reference Phase
VAR: Variable Phase

	Normal Movement		Permitted/Opposed
	Slip/Bypass-Lane Movement		Opposed Slip/Bypass-Lane
	Stopped Movement		Turn On Red
	Other Movement Class (MC) Running		Undetected Movement
	Mixed Running & Stopped MCs		Continuous Movement
	Other Movement Class (MC) Stopped		Phase Transition Applied

SIGNAL OFFSETS

Network: N101 [2063_Opt10D_PM (Network Folder: General)]

Output produced by SIDRA INTERSECTION Version: 9.1.6.228

New Network

Network Category: (None)

Network Cycle Time = 100 seconds (Network Optimum Cycle Time - Minimum Delay)

SIGNAL OFFSETS

Offset Definition: Green Start

Reference Site / CCG: CCG1 [CCG_PM1]¹

Site ID	2440p ¹	2439p ¹	2514p	2860p	2859p
CCG ID (if applicable)	CCG1	CCG1	NA	NA	NA
Offset (sec)	0	0	87	90	57
Program / User	P	P	P	P	P
Reference Phase	A	A	A	A	A
Route ID	R103	R103	R103	R103	R103

¹ Reference Site / CCG as specified in the Network Timing dialog, Network Timing Data tab. This Site / CCG is included in the Route with the highest Offset Priority and is used in offset calculations.

ROUTE OFFSET RESULTS

Route ID: R103

Route Name: TEL WB Off to Sands N

Offset Priority: 1

Offset Method: Start of Green (Leading)

Movement Class for Offset Calculation: Light Vehicles

Site ID	2440p ¹	2439p ¹	2514p	2860p	2859p
Reference Phase	A	A	A	A	A
Offset (sec)	0	0	87	90	57
Calculated offset used (Yes / No)	Yes	Yes	Yes	Yes	Yes
Approach	E	S	S	S	S
Turn	R2	T1	T1	T1	T1
Stopline Travel Distance (m)	0.0	130.3	267.8	156.4	161.7
Stopline Travel Time (sec)	0	11	21	13	13
Start Phase of Movement	D	C	G	A	D1
Relative Offset - Phase (sec)	0	75	21	13	18
Relative Offset - Movement (sec)	0	0	21	13	18
Phase Change Time (sec)	69	56	77	90	8
Displayed Green Start Time (sec)	75	62	83	96	14
Displayed Green Time (sec)	25	38	36	57	28
Effective Green Start Time (sec)	78	65	86	99	17
Effective Green Time (sec)	25	38	36	57	28
Green Time Ratio	0.250	0.380	0.360	0.570	0.280
% Arriving During Green	25.0	61.4	56.9	89.4	75.1
Platoon Ratio	1.000	1.617	1.581	1.568	2.682
Equivalent AT	3	5	5	5	6
Average Delay (sec)	480.0	19.5	24.0	2.8	10.2
% Back of Queue - Distance (m)	497.5	107.2	102.5	30.8	15.4
% Back of Queue - Vehicles	67.1	14.3	13.7	4.3	2.1
Effective Stop Rate	2.37	0.76	0.78	0.19	0.31
Proportion Queued	1.00	0.82	0.84	0.22	0.37

Route ID: R105

Route Name: TEL EB Off to Sands N

Offset Priority: 2

Offset Method: Start of Green (Leading)

Movement Class for Offset Calculation: Light Vehicles

Site ID	2439p ¹	2514p	2860p	2859p
Reference Phase	A	A	A	A
Offset (sec)	0	87	90	57
Calculated offset used (Yes / No)	No	No	No	No

Approach	W	S	S	S
Turn	L2	T1	T1	T1
Stopline Travel Distance (m)	0.0	267.8	156.4	161.7
Stopline Travel Time (sec)	0	21	13	13
Start Phase of Movement	A	G	A	D1
Relative Offset - Phase (sec)	0	77	13	18
Relative Offset - Movement (sec)	0	77	13	18
Phase Change Time (sec)	0	77	90	8
Displayed Green Start Time (sec)	6	83	96	14
Displayed Green Time (sec)	50	36	57	28
Effective Green Start Time (sec)	9	86	99	17
Effective Green Time (sec)	50	36	57	28
Green Time Ratio	0.500	0.360	0.570	0.280
% Arriving During Green	50.0	56.9	89.4	75.1
Platoon Ratio	1.000	1.581	1.568	2.682
Equivalent AT	3	5	5	6
Average Delay (sec)	21.8	24.0	2.8	10.2
% Back of Queue - Distance (m)	56.6	102.5	30.8	15.4
% Back of Queue - Vehicles	7.6	13.7	4.3	2.1
Effective Stop Rate	0.76	0.78	0.19	0.31
Proportion Queued	0.69	0.84	0.22	0.37

Route ID: R104

Route Name: Sands SB

Offset Priority: 3

Offset Method: Start of Green (Leading)

Movement Class for Offset Calculation: Light Vehicles

Site ID	2859p	2860p	2514p	2439p ¹	2440p ¹
Reference Phase	A	A	A	A	A
Offset (sec)	57	90	87	0	0
Calculated offset used (Yes / No)	No	No	No	No	No
Approach	N	N	N	N	N
Turn	T1	T1	T1	T1	T1
Stopline Travel Distance (m)	0.0	170.3	150.0	274.4	129.0
Stopline Travel Time (sec)	0	15	12	22	10
Start Phase of Movement	E	A	A	D	A
Relative Offset - Phase (sec)	0	60	97	82	82
Relative Offset - Movement (sec)	0	60	97	82	82
Phase Change Time (sec)	30	90	87	69	0
Displayed Green Start Time (sec)	36	96	93	75	6
Displayed Green Time (sec)	6	57	26	63	50
Effective Green Start Time (sec)	39	99	96	78	9
Effective Green Time (sec)	6	57	26	63	50
Green Time Ratio	0.060	0.570	0.260	0.630	0.500
% Arriving During Green	6.0	49.6	35.9	78.2	65.3
Platoon Ratio	1.000	0.870	1.382	1.241	1.306
Equivalent AT	3	2	4	4	4
Average Delay (sec)	52.7	16.3	47.6	48.5	19.9
% Back of Queue - Distance (m)	12.6	62.3	91.0	177.2	115.0
% Back of Queue - Vehicles	1.8	8.6	12.2	23.7	15.5
Effective Stop Rate	0.75	0.58	1.08	1.20	0.83
Proportion Queued	1.00	0.72	1.00	0.96	0.85

¹ Reference Site / CCG as specified in the Network Timing dialog, Network Timing Data tab. This Site / CCG is included in the Route with the highest Offset Priority and is used in offset calculations.

SITE LAYOUT

 Site: 2122p [2122 TEL Te Puke Highway PM (Site Folder: General)]

New Site
Site Category: (None)
Roundabout

Layout pictures are schematic functional drawings reflecting input data. They are not design drawings.

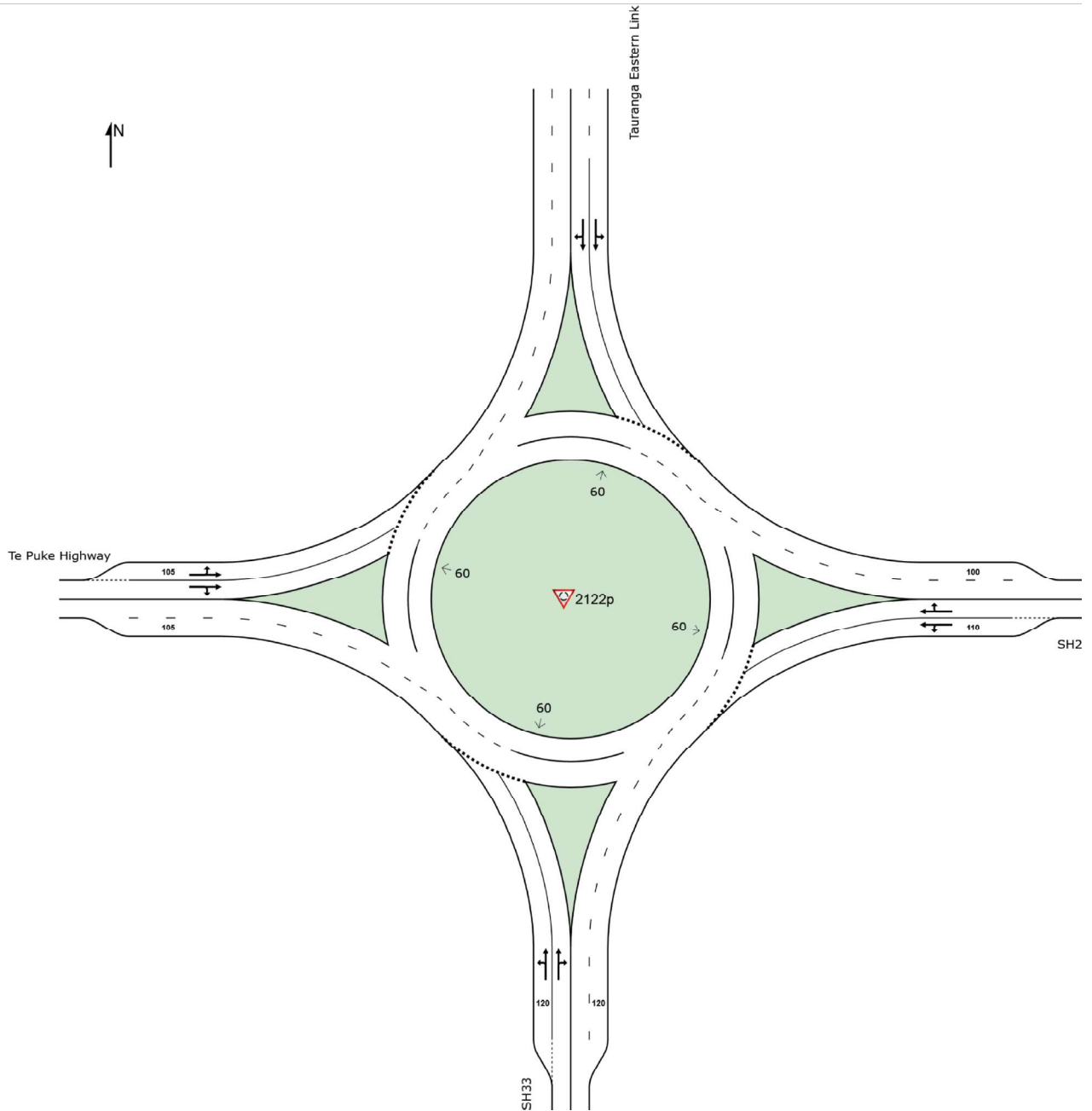

SIDRA INTERSECTION 9.1 | Copyright © 2000-2024 Kcelik and Associates Pty Ltd | sidrasolutions.com

Organisation: AJW | Licence: NETWORK / 1PC | Created: Friday, 27 March 2026 8:00:23 pm

Project: C:\Users\anna\OneDrive\AW Consulting\Projects\Boffa Miskell Jobs\Wairakei South\ITA Work Feb 2026\Final SIDRA Modelling\Third Round Base Sidra File\2063_TTHM 10D Mitigated.sip9

MOVEMENT SUMMARY

 Site: 2122p [2122 TEL Te Puke Highway PM (Site Folder: General)]

Output produced by SIDRA INTERSECTION Version: 9.1.6.228

New Site
Site Category: (None)
Roundabout

Vehicle Movement Performance															
Mov ID	Turn	Mov Class	Demand Flows		Arrival Flows		Deg. Satn	Aver. Delay	Level of Service	95% Back Of Queue	Prop. Que	Eff. Stop Rate	Aver. No. of Cycles	Aver. Speed	
			[Total HV]	%	[Total HV]	%	v/c	sec		[Veh. veh	Dist] m			km/h	
South: SH33															
1	L2	All MCs	158	10.0	158	10.0	0.782	19.9	LOS B	9.6	74.1	1.00	1.25	1.73	49.1
2	T1	All MCs	613	13.7	613	13.7	0.782	21.1	LOS C	9.6	74.1	1.00	1.24	1.72	39.2
3	R2	All MCs	1	0.0	1	0.0	0.782	29.7	LOS C	7.5	58.4	1.00	1.22	1.71	38.3
Approach			772	13.0	772	13.0	0.782	20.9	LOS C	9.6	74.1	1.00	1.24	1.72	46.6
East: SH2															
4	L2	All MCs	1	0.0	1	0.0	0.281	5.8	LOS A	1.6	11.9	0.78	0.62	0.78	46.2
5	T1	All MCs	181	7.6	181	7.6	0.281	5.0	LOS A	1.6	11.9	0.78	0.62	0.78	49.7
6	R2	All MCs	998	6.6	998	6.6	1.096	69.1	LOS E	46.9	346.6	1.00	2.76	4.75	26.9
Approach			1180	6.8	1180	6.8	1.096	59.2	LOS E	46.9	346.6	0.97	2.43	4.14	40.0
North: Tauranga Eastern Link															
7	L2	All MCs	743	10.8	743	10.8	0.683	4.5	LOS A	7.1	54.6	0.80	0.68	0.92	46.4
8	T1	All MCs	462	15.7	462	15.7	0.683	4.8	LOS A	7.1	54.6	0.82	0.73	0.97	45.3
9	R2	All MCs	257	13.9	257	13.9	0.683	11.8	LOS B	6.7	53.0	0.82	0.74	0.98	49.6
Approach			1462	12.9	1462	12.9	0.683	5.8	LOS A	7.1	54.6	0.81	0.70	0.95	48.7
West: Te Puke Highway															
10	L2	All MCs	207	18.8	207	18.8	0.615	18.2	LOS B	4.5	36.4	0.96	1.07	1.38	49.2
11	T1	All MCs	224	11.3	224	11.3	0.674	16.4	LOS B	6.8	52.8	1.00	1.12	1.51	49.2
12	R2	All MCs	192	14.8	192	14.8	0.674	22.5	LOS C	6.8	52.8	1.00	1.13	1.53	49.1
Approach			623	14.9	623	14.9	0.674	18.8	LOS B	6.8	52.8	0.98	1.11	1.47	49.2
All Vehicles			4037	11.4	4037	11.4	1.096	26.3	LOS C	46.9	346.6	0.92	1.37	2.11	46.8

Site Level of Service (LOS) Method: Delay (SIDRA). Site LOS Method is specified in the Parameter Settings dialog (Options tab).

Roundabout LOS Method: SIDRA Roundabout LOS.

Vehicle movement LOS values are based on average delay per movement.

Intersection and Approach LOS values are based on average delay for all vehicle movements.

Roundabout Capacity Model: SIDRA Standard.

Delay Model: SIDRA Standard (Control Delay: Geometric Delay is included).

Queue Model: SIDRA queue estimation methods are used for Back of Queue and Queue at Start of Gap.

Gap-Acceptance Capacity Formula: SIDRA Standard (Akçelik M3D).

HV (%) values are calculated for All Movement Classes of All Heavy Vehicle Model Designation.

Arrival Flows used in performance calculations are adjusted to include any Initial Queued Demand and Upstream Capacity Constraint effects.

SIDRA INTERSECTION 9.1 | Copyright © 2000-2024 Akcelik and Associates Pty Ltd | sidrasolutions.com

Organisation: AJW | Licence: NETWORK / 1PC | Processed: Friday, 27 March 2026 12:20:02 pm

Project: C:\Users\lannaj\OneDrive\AW Consulting\Projects\Boffa Miskell Jobs\Wairakei South\ITA Work Feb 2026\Final SIDRA Modelling\Third Round Base Sidra File\2063_TTHM 10D Mitigated.sip9

SITE LAYOUT

Site: 1335 [1335 Tara Rd Parton Rd RAB PM (Site Folder: General)]

New Site
Site Category: (None)
Roundabout

Layout pictures are schematic functional drawings reflecting input data. They are not design drawings.

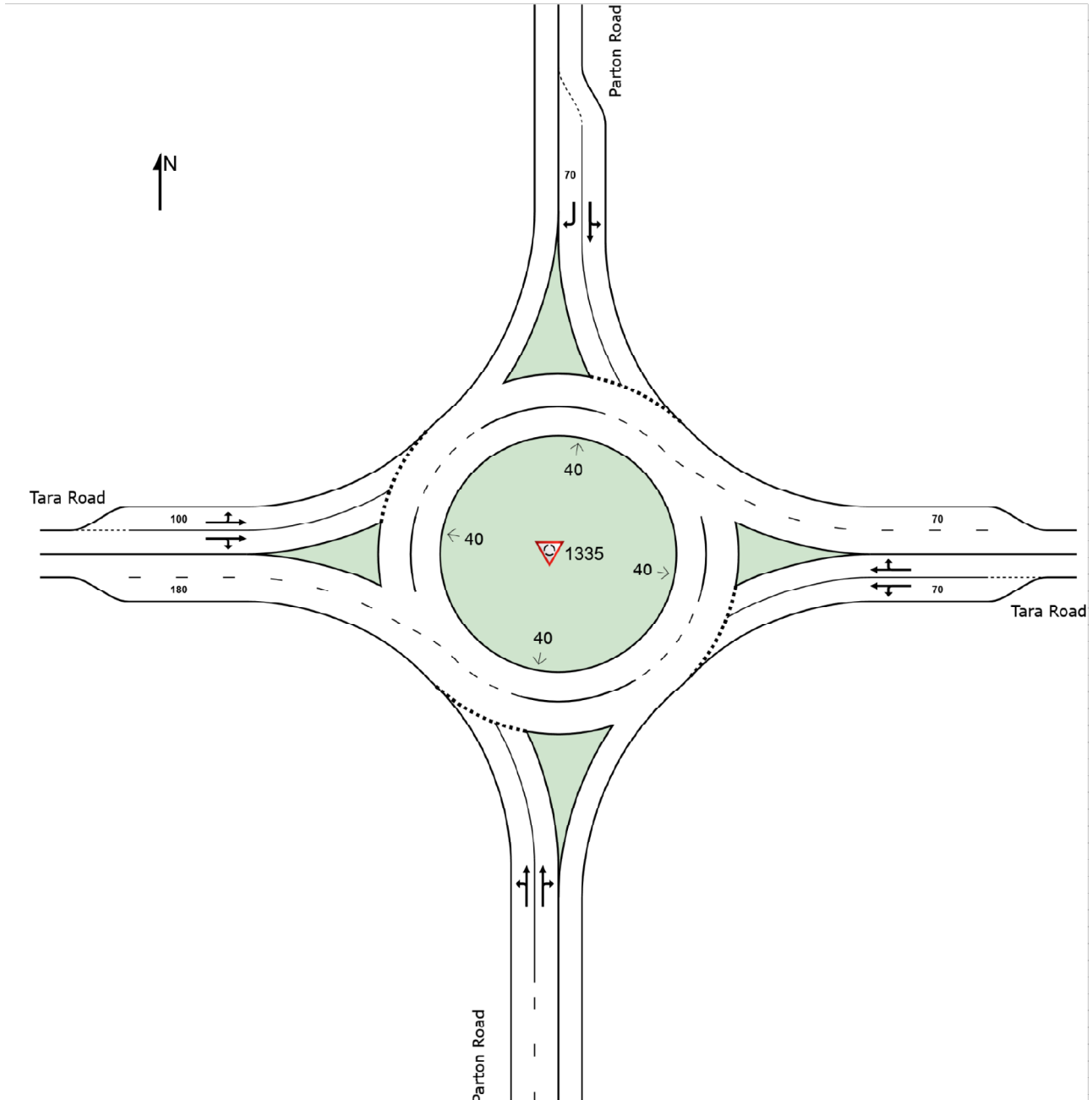

SIDRA INTERSECTION 9.1 | Copyright © 2000-2024 Akcelik and Associates Pty Ltd | sidrasolutions.com

Organisation: AJW | Licence: NETWORK / 1PC | Created: Friday, 27 March 2026 8:00:19 pm

Project: C:\Users\annaj\OneDrive\AW Consulting\Projects\Boffa Miskell Jobs\Wairakei South\ITA Work Feb 2026\Final SIDRA Modelling\Third Round Base Sidra File\2063_TTHM 10D Mitigated.sip9

MOVEMENT SUMMARY

 Site: 1335 [1335 Tara Rd Parton Rd RAB PM (Site Folder: General)]

Output produced by SIDRA INTERSECTION Version: 9.1.6.228

New Site
Site Category: (None)
Roundabout

Vehicle Movement Performance															
Mov ID	Turn	Mov Class	Demand Flows		Arrival Flows		Deg. Satn	Aver. Delay	Level of Service	95% Back Of Queue	Prop. Que	Eff. Stop Rate	Aver. No. of Cycles	Aver. Speed	
			[Total HV]	%	[Total HV]	%	v/c	sec		[Veh. veh	Dist] m			km/h	
South: Parton Road															
1	L2	All MCs	133	3.7	133	3.7	0.159	4.6	LOS A	0.7	4.9	0.58	0.61	0.58	50.0
2	T1	All MCs	62	3.7	62	3.7	0.192	3.1	LOS A	0.9	6.4	0.57	0.62	0.57	45.1
3	R2	All MCs	144	3.7	144	3.7	0.192	9.4	LOS A	0.9	6.4	0.57	0.62	0.57	44.6
Approach			339	3.7	339	3.7	0.192	6.4	LOS A	0.9	6.4	0.57	0.62	0.57	46.6
East: Tara Road															
4	L2	All MCs	122	3.7	122	3.7	0.321	3.0	LOS A	1.6	11.6	0.43	0.31	0.43	47.1
5	T1	All MCs	653	3.7	653	3.7	0.321	2.5	LOS A	1.6	11.6	0.44	0.31	0.44	50.7
6	R2	All MCs	12	3.7	12	3.7	0.321	8.7	LOS A	1.6	11.3	0.45	0.31	0.45	46.6
Approach			786	3.7	786	3.7	0.321	2.6	LOS A	1.6	11.6	0.44	0.31	0.44	50.0
North: Parton Road															
7	L2	All MCs	9	3.7	9	3.7	0.079	5.7	LOS A	0.4	2.6	0.63	0.58	0.63	46.3
8	T1	All MCs	47	3.7	47	3.7	0.079	4.7	LOS A	0.4	2.6	0.63	0.58	0.63	46.5
9	R2	All MCs	125	3.7	125	3.7	0.129	10.2	LOS B	0.7	4.8	0.64	0.72	0.64	46.1
Approach			182	3.7	182	3.7	0.129	8.6	LOS A	0.7	4.8	0.64	0.67	0.64	46.2
West: Tara Road															
10	L2	All MCs	154	3.7	154	3.7	0.272	4.3	LOS A	1.4	10.2	0.41	0.44	0.41	50.3
11	T1	All MCs	619	3.7	619	3.7	0.446	3.9	LOS A	2.9	21.1	0.44	0.44	0.44	49.9
12	R2	All MCs	138	3.7	138	3.7	0.446	10.3	LOS B	2.9	21.1	0.45	0.45	0.45	49.1
Approach			911	3.7	911	3.7	0.446	4.9	LOS A	2.9	21.1	0.44	0.44	0.44	49.9
All Vehicles			2218	3.7	2218	3.7	0.446	4.6	LOS A	2.9	21.1	0.48	0.44	0.48	49.1

Site Level of Service (LOS) Method: Delay (SIDRA). Site LOS Method is specified in the Parameter Settings dialog (Options tab).

Roundabout LOS Method: SIDRA Roundabout LOS.

Vehicle movement LOS values are based on average delay per movement.

Intersection and Approach LOS values are based on average delay for all vehicle movements.

Roundabout Capacity Model: SIDRA Standard.

Delay Model: SIDRA Standard (Control Delay: Geometric Delay is included).

Queue Model: SIDRA queue estimation methods are used for Back of Queue and Queue at Start of Gap.

Gap-Acceptance Capacity Formula: SIDRA Standard (Akçelik M3D).

HV (%) values are calculated for All Movement Classes of All Heavy Vehicle Model Designation.

Arrival Flows used in performance calculations are adjusted to include any Initial Queued Demand and Upstream Capacity Constraint effects.

SIDRA INTERSECTION 9.1 | Copyright © 2000-2024 Akcelik and Associates Pty Ltd | sidrasolutions.com

Organisation: AJW | Licence: NETWORK / 1PC | Processed: Friday, 27 March 2026 12:20:05 pm

Project: C:\Users\lannaj\OneDrive\AW Consulting\Projects\Boffa Miskell Jobs\Wairakei South\ITA Work Feb 2026\Final SIDRA Modelling\Third Round Base Sidra File\2063_TTHM 10D Mitigated.sip9

Appendix 7: HCM Ramp Capacity Assessments

Appendix 8: Link Area of Influence

Links

- 1 The Boulevard Road - Bill Miller (BM) Drive
- 2 Bill Miller (BM) Drive - Te Okura Drive (TOD)
- 3 Te Okura Drive - PEI
- 4 PEI West
- 5 Wairakei South (WS) West
- 6 Wairakei South (WS) East
- 7 Domain Road West
- 8 PEI North
- 9 PEI South
- 10 TEL South (Sth)
- 11 Te Puke Highway (TPH) North
- 12 Rangituru West
- 13 Bell Road South
- 14 Domain Road West (Welcome Bay Road)
- 15 Domain Road Interchange South
- 16 Domain Road Interchange North
- 17 Parton Road
- 18 Tara Road
- 19 Te Okura Drive (East of Parton Road)
- 20 Seddon Street Connection

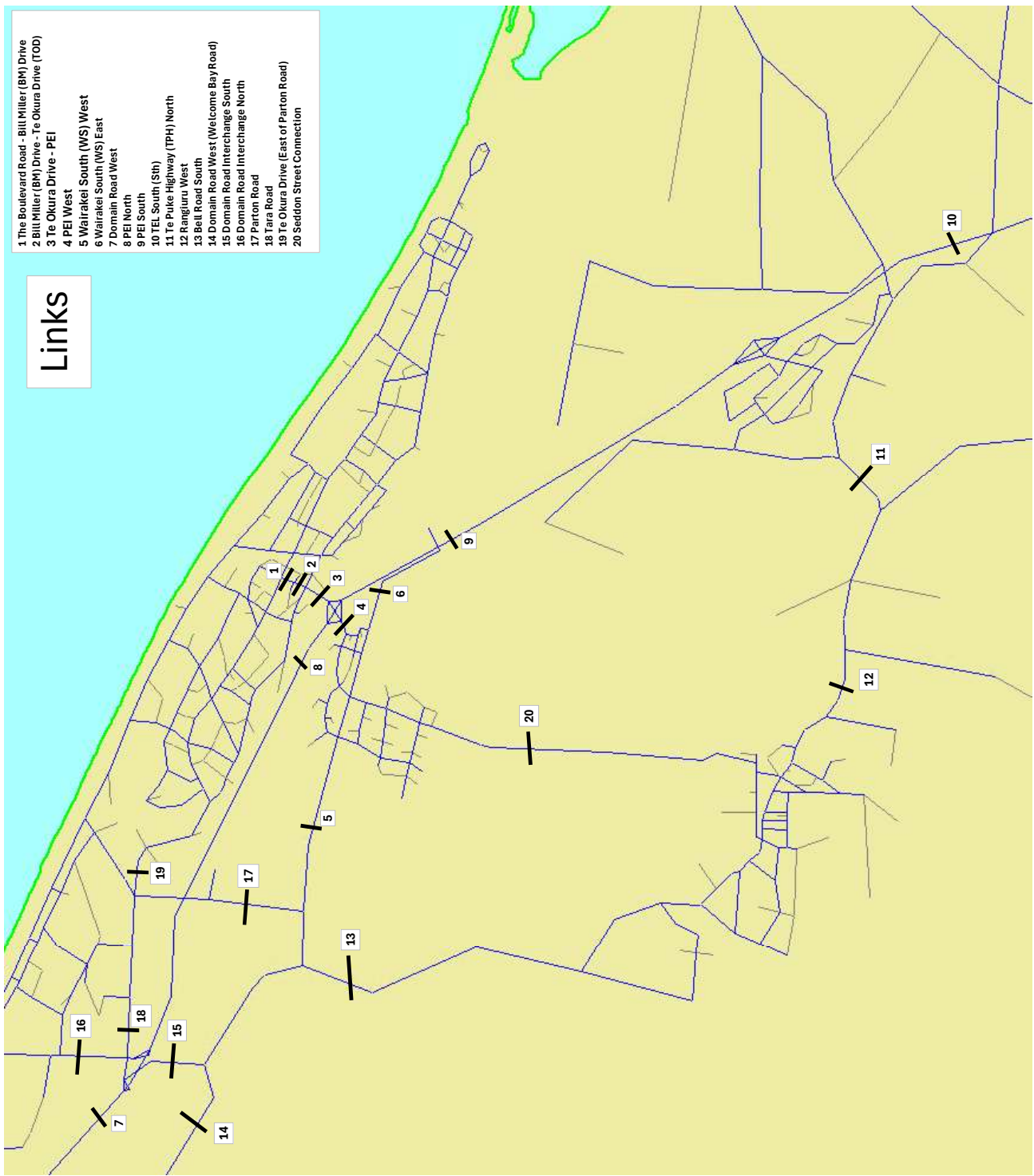

With Te Tumu

Site	Name	2035			2048			2063					
		Volume Change	LOS (DM)	LOS (CS-DM)	Outcome	Volume Change	LOS (DM)	LOS (CS-DM)	Outcome	Volume Change	LOS (DM)	LOS (CS-DM)	Outcome
1	Sands Ave (Boulevard - Bill Miller)	13.7%	A-B	A-B	Ok	14.4%	A-B	A-B	Ok	22.9%	A-B	A-B	Ok
2	Sands Ave (Bill Miller-TOD)	17.0%	A-B	A-B	Ok	21.0%	A-B	A-B	Ok	31.3%	A-B	A-B	Ok
3	Sands Ave (TOD-PEI)	42.7%	A-B	C	Ok	39.4%	D	E	Investigate	48.8%	D	E	Investigate
4	Sands Ave (west of PEI)	New link	N/A	A-B	Ok	New link	N/A	C	Ok	New link	N/A	C	Ok
5	Bell Road (east of WS)	New link	A-B	C	Ok	New link	A-B	C	Ok	New link	A-B	C	Ok
6	Bell Road (east of WS)	N/A	D	D	Ok	N/A	D	D	Ok	-100.0%	D	D	Ok
7	TEL (west of Domain)	2.6%	D	D	Ok	3.9%	D	D	Ok	2.9%	D	D	Ok
8	TEL (north of PEI)	2.5%	A-B	A-B	Ok	6.1%	C	C	Ok	6.0%	C	D	Ok
9	TEL (south of PEI)	1.4%	A-B	A-B	Ok	6.0%	C	C	Ok	6.6%	C	C	Ok
10	TEL (north of SH33)	1.2%	A-B	A-B	Ok	5.5%	A-B	A-B	Ok	6.0%	A-B	A-B	Ok
11	Rangioru (TPH north)	-5.9%	D	D	Ok	-1.9%	D	D	Ok	3.5%	D	D	Ok
12	Te Puke Hwy (west of Rangioru)	-2.9%	D	D	Ok	-3.2%	D	D	Ok	2.4%	D	D	Ok
13	Te Puke Hwy (south of Bell)	10.4%	E	E	Investigate	7.6%	E	E	Ok	0.9%	E	E	Ok
14	Welcome Bay Rd (west of Domain)	5.2%	C	C	Ok	6.7%	D	D	Ok	3.3%	E	E	Ok
15	Domain Rd (south of interchange)	9.4%	E	E	Ok	2.0%	E	E	Ok	10.0%	E	E	Investigate
16	Domain Rd (north of interchange)	3.3%	C	C	Ok	3.2%	D	D	Ok	2.0%	D	D	Ok
17	Parton Rd (north of Bell)	-13.2%	C	C	Ok	10.0%	A-B	C	Ok	-1.1%	C	C	Ok
18	Tara Road	-1.8%	C	C	Ok	-3.2%	A-B	A-B	Ok	-2.7%	A-B	A-B	Ok
19	TOD (east of Parton)	-6.3%	E	D	Ok	-1.9%	D	D	Ok	-1.2%	D	D	Ok
20	Seddon Road Connection	N/A	N/A	N/A	Ok	N/A	N/A	N/A	Ok	N/A	N/A	N/A	Ok
21	SH2 east of TEL/Te Puke Hwy RAB	3.0%	D	D	Ok	4.7%	E	E	Ok	4.4%	E	E	Ok

Without Te Tumu

Site	Name	2035			2048			2048			2048		
		Volume Change	LOS (DM)	LOS (ST1-DM)	Outcome	Volume Change	LOS (DM)	LOS (ST1-DM)	Outcome	Volume Change	LOS (DM)	LOS (ST1-DM)	Outcome
1	Sands Ave (Boulevard - Bill Miller)	7.8%	A-B	A-B	Ok	9.7%	A-B	A-B	Ok	8.1%	A-B	A-B	Ok
2	Sands Ave (Bill Miller-TOD)	10.5%	A-B	A-B	Ok	13.3%	A-B	A-B	Ok	10.6%	A-B	A-B	Ok
3	Sands Ave (TOD-PEI)	27.9%	A-B	C	Ok	10.7%	D	D	Ok	3.8%	D	D	Ok
4	Sands Ave (west of PEI)	New link	N/A	A-B	Ok	New link	N/A	C	Ok	New link	N/A	C	Ok
5	Bell Road (east of WS)	New link	A-B	C	Ok	New link	A-B	C	Ok	New link	A-B	C	Ok
6	Bell Road (east of WS)	N/A	D	N/A	Ok	N/A	D	N/A	Ok	-100.0%	D	N/A	Ok
7	TEL (west of Domain)	-0.3%	D	D	Ok	-0.8%	D	D	Ok	-4.3%	D	D	Ok
8	TEL (north of PEI)	-3.7%	A-B	A-B	Ok	-4.6%	C	C	Ok	-9.8%	C	C	Ok
9	TEL (south of PEI)	-3.8%	A-B	A-B	Ok	-1.6%	C	C	Ok	-5.6%	C	C	Ok
10	TEL (north of SH33)	-5.4%	A-B	A-B	Ok	-4.3%	A-B	A-B	Ok	-9.0%	A-B	A-B	Ok
11	Rangioru (TPH north)	-7.3%	D	D	Ok	-5.0%	D	D	Ok	-1.7%	D	D	Ok
12	Te Puke Hwy (west of Rangioru)	-3.5%	D	D	Ok	-5.4%	D	D	Ok	-1.1%	D	D	Ok
13	Te Puke Hwy (south of Bell)	9.1%	E	E	Ok	7.1%	E	E	Ok	0.3%	E	E	Ok
14	Welcome Bay Rd (west of Domain)	2.3%	C	C	Ok	4.4%	D	D	Ok	-4.1%	E	E	Ok
15	Domain Rd (south of interchange)	9.7%	E	E	Ok	2.1%	E	E	Ok	7.0%	E	E	Ok
16	Domain Rd (north of interchange)	3.0%	C	C	Ok	1.6%	D	D	Ok	-0.7%	D	D	Ok
17	Parton Rd (north of Bell)	-12.2%	C	C	Ok	11.1%	A-B	C	Ok	-2.5%	C	C	Ok
18	Tara Road	-3.1%	C	C	Ok	-2.3%	A-B	A-B	Ok	-0.1%	A-B	A-B	Ok
19	TOD (east of Parton)	-5.1%	E	D	Ok	0.1%	D	D	Ok	1.9%	D	D	Ok
20	Seddon Road Connection	N/A	N/A	N/A	Ok	N/A	N/A	N/A	Ok	N/A	N/A	N/A	Ok
21	SH2 east of TEL/Te Puke Hwy RAB		D	D	Ok		E	D	Ok		E	E	Ok

Appendix 9: Intersection Area of Influence

Intersections

- 1 The Boulevard/Wairakei TC/Sands Avenue
- 2 Bill Miller Drive/Sands Avenue
- 3 Te Okura Drive/Sands Avenue
- 4 PEI Off Ramp/Sands Avenue/PEI On Ramp
- 5 PEI Off Ramp/Wairakei South Access/PEI On Ramp
- 6 Node 10003 (New)
- 7 Node 10007 (New)
- 8 Node 10008 (New)
- 8a Node 10010 (New)
- 9 Node 10011 (New)
- 10 Node 10012 (New)
- 11 Node 10013 (New)
- 12 Node 10024 (New)
- 13 Node 10004 (New)
- 14 Node 10043 (New)
- 15 Node 6812 (New)
- 16 Node 10033 (New)
- 17 Node 10015 (New)
- 18 Node 10016 (New)
- 19 Node 10017 (New)
- 20 Node 10018 (New)
- 21 Node 10019 (New)
- 22 TePuke Hwy/Bell Road
- 23 TEL southern roundabout
- 24 Parton Rd/Bell Rd
- 25 Te Okuroa Dr / Stevenson Dr
- 26 Te Okuroa Dr / Parton Rd / Tara Rd
- 27 Te Puke Hwy / Welcome Bay Rd
- 28 TEL Southern Roundabout at Domain Rd Interchange
- 29 TEL Northern Roundabout at Domain Rd Interchange
- 30 Te Okuroa Dr / The Boulevard

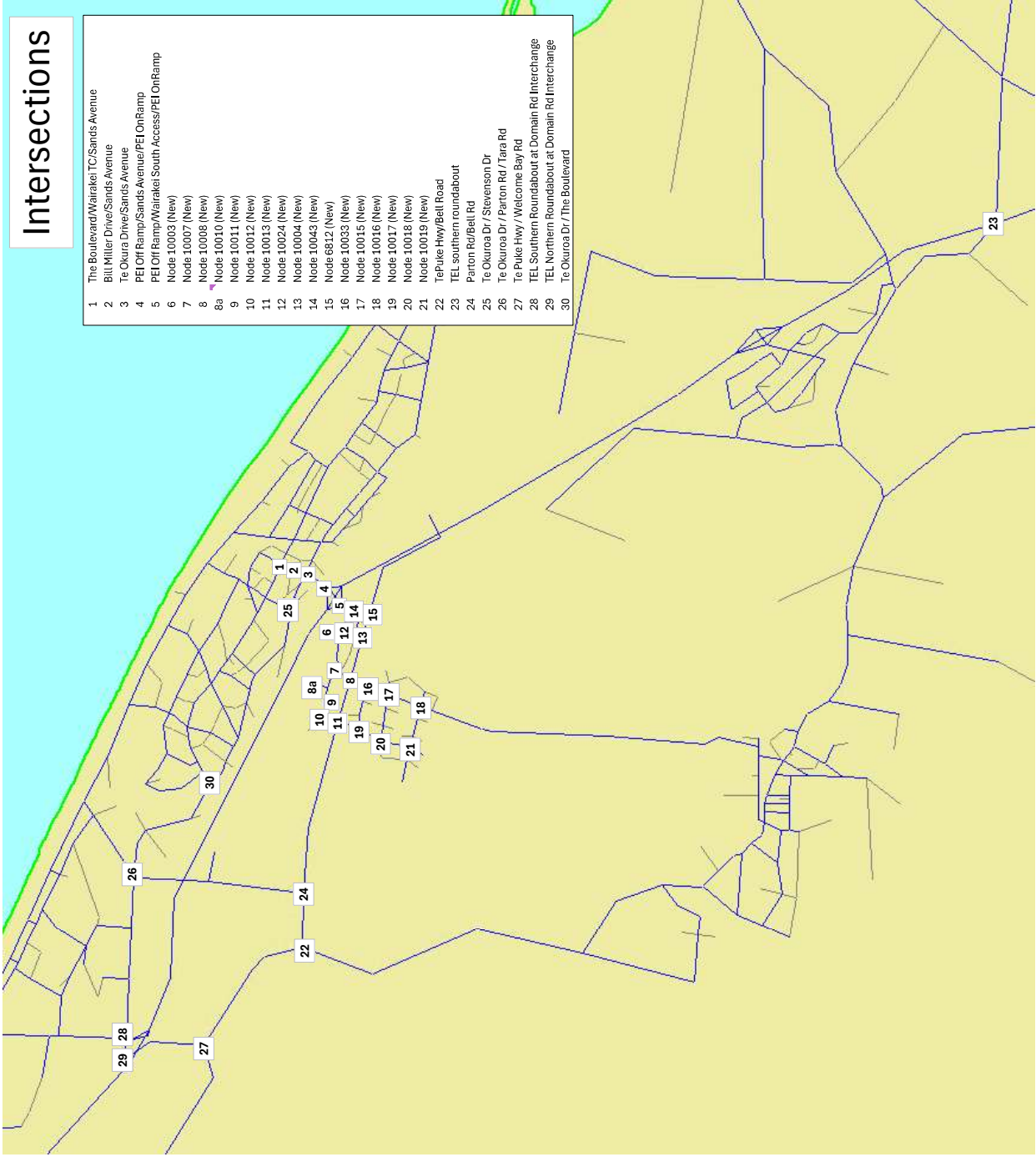

Node	Becca number	Name	2085 AM			2085 PM			2048 AM			2048 PM			2083 AM			2083 PM								
			Vol Change	LOS (DM)	LOS (CS-DM)	Outcome	Vol Change	LOS (DM)	LOS (CS-DM)	Outcome	Vol Change	LOS (DM)	LOS (CS-DM)	Outcome	Vol Change	LOS (DM)	LOS (CS-DM)	Outcome	Vol Change	LOS (DM)	LOS (CS-DM)	Outcome				
2859	1	The Boulevard/Wairakei TC/Sands Avenue	-0.9%	A-C	A-C	Ok	21.0%	A-C	A-C	Ok	-8.0%	A-C	A-C	Ok	7.1%	A-C	A-C	Ok	17.5%	A-C	A-C	Ok	7.7%	D	A-C	Ok
2860	2	Bill Miller Drive/Sands Avenue	9.5%	A-C	A-C	Ok	23.8%	A-C	A-C	Ok	35.6%	A-C	A-C	Ok	14.3%	A-C	A-C	Ok	31.5%	A-C	A-C	Ok	15.6%	A-C	A-C	Ok
2914	3	Te Okura Drive/Sands Avenue	35.4%	D	D	Ok	37.9%	D	D	Ok	20.5%	E	D	Ok	20.3%	E	D	Ok	19.3%	E	D	Ok	18.2%	E	D	Ok
2430	4	PEI Off Ramp/Sands Avenue/PEI OnRamp	116.3%	A-C	A-C	Ok	85.5%	A-C	A-C	Ok	36.3%	A-C	A-C	Ok	35.7%	A-C	A-C	Ok	32.7%	A-C	A-C	Ok	30.2%	A-C	A-C	Ok
2440	5	PEI Off Ramp/Wairakei South Access/PEI OnRamp	175.7%	A-C	A-C	Ok	132.5%	A-C	A-C	Ok	145.8%	A-C	A-C	Ok	115.1%	A-C	A-C	Ok	129.9%	A-C	A-C	Ok	93.7%	A-C	A-C	Ok
10003	6	Note 10003	New Int	-	A-C	Ok	New Int	-	A-C	Ok	New Int	-	D	Ok	New Int	-	D	Ok	New Int	-	D	Ok	New Int	-	D	Ok
10007	7	Note 10007	New Int	-	A-C	Ok	New Int	-	A-C	Ok	New Int	-	D	Ok	New Int	-	D	Ok	New Int	-	D	Ok	New Int	-	D	Ok
10008	8	Note 10008	New Int	-	A-C	Ok	New Int	-	A-C	Ok	New Int	-	D	Ok	New Int	-	D	Ok	New Int	-	D	Ok	New Int	-	D	Ok
10010	8a	Note 10010	New Int	-	A-C	Ok	New Int	-	A-C	Ok	New Int	-	D	Ok	New Int	-	D	Ok	New Int	-	D	Ok	New Int	-	D	Ok
10011	9	Note 10011	New Int	-	A-C	Ok	New Int	-	A-C	Ok	New Int	-	D	Ok	New Int	-	D	Ok	New Int	-	D	Ok	New Int	-	D	Ok
10012	10	Note 10012	New Int	-	A-C	Ok	New Int	-	A-C	Ok	New Int	-	D	Ok	New Int	-	D	Ok	New Int	-	D	Ok	New Int	-	D	Ok
10013	11	Note 10013	New Int	-	A-C	Ok	New Int	-	A-C	Ok	New Int	-	D	Ok	New Int	-	D	Ok	New Int	-	D	Ok	New Int	-	D	Ok
10014	12	Note 10014	New Int	-	A-C	Ok	New Int	-	A-C	Ok	New Int	-	D	Ok	New Int	-	D	Ok	New Int	-	D	Ok	New Int	-	D	Ok
10024	13	Note 10024	New Int	-	A-C	Ok	New Int	-	A-C	Ok	New Int	-	D	Ok	New Int	-	D	Ok	New Int	-	D	Ok	New Int	-	D	Ok
10043	14	Note 10043	New Int	-	A-C	Ok	New Int	-	A-C	Ok	New Int	-	D	Ok	New Int	-	D	Ok	New Int	-	D	Ok	New Int	-	D	Ok
6812	15	Note 6812	New Int	-	A-C	Ok	New Int	-	A-C	Ok	New Int	-	D	Ok	New Int	-	D	Ok	New Int	-	D	Ok	New Int	-	D	Ok
10033	16	Note 10033	No Int	-	-	Ok	No Int	-	-	Ok	No Int	-	-	Ok	No Int	-	-	Ok	No Int	-	-	Ok	No Int	-	-	Ok
10035	17	Note 10035	No Int	-	-	Ok	No Int	-	-	Ok	No Int	-	-	Ok	No Int	-	-	Ok	No Int	-	-	Ok	No Int	-	-	Ok
10016	18	Note 10016	No Int	-	-	Ok	No Int	-	-	Ok	No Int	-	-	Ok	No Int	-	-	Ok	No Int	-	-	Ok	No Int	-	-	Ok
10017	19	Note 10017	No Int	-	-	Ok	No Int	-	-	Ok	No Int	-	-	Ok	No Int	-	-	Ok	No Int	-	-	Ok	No Int	-	-	Ok
10018	20	Note 10018	No Int	-	-	Ok	No Int	-	-	Ok	No Int	-	-	Ok	No Int	-	-	Ok	No Int	-	-	Ok	No Int	-	-	Ok
10019	21	Note 10019	No Int	-	-	Ok	No Int	-	-	Ok	No Int	-	-	Ok	No Int	-	-	Ok	No Int	-	-	Ok	No Int	-	-	Ok
2140	22	Te Puke Hwy/Bell Road	13.4%	A-C	A-C	Ok	16.0%	A-C	A-C	Ok	14.3%	A-C	A-C	Ok	17.1%	A-C	A-C	Ok	15.2%	A-C	A-C	Ok	16.2%	A-C	A-C	Ok
2122	23	TEL Southern Roundabout	3.0%	A-C	A-C	Ok	2.7%	A-C	A-C	Ok	4.8%	A-C	A-C	Ok	5.1%	A-C	A-C	Ok	3.5%	A-C	A-C	Ok	4.0%	A-C	A-C	Ok
3348	24	Patton Rd/Bell Rd	61.0%	A-C	A-C	Ok	42.6%	A-C	A-C	Ok	95.3%	A-C	A-C	Ok	104.4%	A-C	A-C	Ok	101.6%	A-C	A-C	Ok	84.0%	A-C	A-C	Ok
3349	25	Te Okura Dr / Paton Rd / Tane Rd	4.7%	A-C	A-C	Ok	4.6%	A-C	A-C	Ok	6.2%	A-C	A-C	Ok	7.8%	A-C	A-C	Ok	5.3%	A-C	A-C	Ok	5.4%	A-C	A-C	Ok
1335	26	Te Okura Dr / Paton Rd / Tane Rd	-4.7%	A-C	A-C	Ok	-6.9%	A-C	A-C	Ok	0.2%	A-C	A-C	Ok	-0.2%	A-C	A-C	Ok	1.3%	A-C	A-C	Ok	-1.4%	A-C	A-C	Ok
1332	27	Te Puke Hwy / Welcome Bay Rd	6.6%	A-C	A-C	Ok	10.2%	A-C	A-C	Ok	2.7%	A-C	A-C	Ok	7.0%	A-C	A-C	Ok	6.5%	A-C	A-C	Ok	7.2%	E	A-C	Ok
1333	28	TEL Southern Roundabout at Domain Rd Interchange	-0.6%	A-C	A-C	Ok	-0.3%	A-C	A-C	Ok	-2.4%	A-C	A-C	Ok	0.8%	A-C	A-C	Ok	0.2%	A-C	A-C	Ok	-0.1%	E	A-C	Ok
1331	29	TEL Northern Roundabout at Domain Rd Interchange	0.4%	A-C	A-C	Ok	1.4%	A-C	A-C	Ok	-3.3%	A-C	A-C	Ok	-0.3%	A-C	A-C	Ok	-0.7%	A-C	A-C	Ok	-0.5%	A-C	A-C	Ok
2862	30	Te Okura Dr / The Boulevard	-6.4%	A-C	A-C	Ok	-8.9%	A-C	A-C	Ok	-4.1%	A-C	A-C	Ok	-4.9%	A-C	A-C	Ok	-4.0%	A-C	A-C	Ok	-3.7%	A-C	A-C	Ok

Node	Becca number	Name	2085 AM			2085 PM			2048 AM			2048 PM			2083 AM			2083 PM								
			Vol Change	LOS (DM)	LOS (CS-DM)	Outcome	Vol Change	LOS (DM)	LOS (CS-DM)	Outcome	Vol Change	LOS (DM)	LOS (CS-DM)	Outcome	Vol Change	LOS (DM)	LOS (CS-DM)	Outcome	Vol Change	LOS (DM)	LOS (CS-DM)	Outcome				
2859	1	The Boulevard/Wairakei TC/Sands Avenue	-34.5%	A-C	A-C	Ok	32.2%	A-C	A-C	Ok	-36.2%	A-C	A-C	Ok	-8.4%	D	A-C	Ok	44.7%	A-C	A-C	Ok	-12.0%	D	A-C	Ok
2860	2	Bill Miller Drive/Sands Avenue	-12.0%	A-C	A-C	Ok	25.4%	A-C	A-C	Ok	18.6%	A-C	A-C	Ok	4.1%	A-C	A-C	Ok	21.6%	A-C	A-C	Ok	3.5%	A-C	A-C	Ok
2430	4	PEI Off Ramp/Sands Avenue/PEI OnRamp	14.7%	A-C	A-C	Ok	64.7%	A-C	A-C	Ok	3.6%	A-C	A-C	Ok	13.5%	A-C	A-C	Ok	28.5%	A-C	A-C	Ok	-18.8%	A-C	A-C	Ok
2440	5	PEI Off Ramp/Wairakei South Access/PEI OnRamp	140.3%	A-C	A-C	Ok	114.3%	A-C	A-C	Ok	102.2%	A-C	A-C	Ok	92.2%	A-C	A-C	Ok	75.5%	A-C	A-C	Ok	69.7%	A-C	A-C	Ok
10003	6	Note 10003	New Int	-	A-C	Ok	New Int	-	A-C	Ok	New Int	-	D	Ok	New Int	-	D	Ok	New Int	-	D	Ok	New Int	-	D	Ok
10007	7	Note 10007	New Int	-	A-C	Ok	New Int	-	A-C	Ok	New Int	-	D	Ok	New Int	-	D	Ok	New Int	-	D	Ok	New Int	-	D	Ok
10008	8	Note 10008	New Int	-	A-C	Ok	New Int	-	A-C	Ok	New Int	-	D	Ok	New Int	-	D	Ok	New Int	-	D	Ok	New Int	-	D	Ok
10010	8	Note 10010	New Int	-	A-C	Ok	New Int	-	A-C	Ok	New Int	-	D	Ok	New Int	-	D	Ok	New Int	-	D	Ok	New Int	-	D	Ok
10011	9	Note 10011	New Int	-	A-C	Ok	New Int	-	A-C	Ok	New Int	-	D	Ok	New Int	-	D	Ok	New Int	-	D	Ok	New Int	-	D	Ok
10012	10	Note 10012	New Int	-	A-C	Ok	New Int	-	A-C	Ok	New Int	-	D	Ok	New Int	-	D	Ok	New Int	-	D	Ok	New Int	-	D	Ok
10013	11	Note 10013	New Int	-	A-C	Ok	New Int	-	A-C	Ok	New Int	-	D	Ok	New Int	-	D	Ok	New Int	-	D	Ok	New Int	-	D	Ok
10024	12	Note 10024	New Int	-	A-C	Ok	New Int	-	A-C	Ok	New Int	-	D	Ok	New Int	-	D	Ok	New Int	-	D	Ok	New Int	-	D	Ok
10004	13	Note 10004	New Int	-	A-C	Ok	New Int	-	A-C	Ok	New Int	-	D	Ok	New Int	-	D	Ok	New Int	-	D	Ok	New Int	-	D	Ok
6812	15	Note 6812	New Int	-	A-C	Ok	New Int	-	A-C	Ok	New Int	-	D	Ok	New Int	-	D	Ok	New Int	-	D	Ok	New Int	-	D	Ok
10033	16	Note 10033	No Int	-	-	Ok	No Int	-	-	Ok	No Int	-	-	Ok	No Int	-	-	Ok	No Int	-	-	Ok	No Int	-	-	Ok
10035	17	Note 10035	No Int	-	-	Ok	No Int	-	-	Ok	No Int	-	-	Ok	No Int	-	-	Ok	No Int	-	-	Ok	No Int	-	-	Ok
1335	26	Te Okura Dr / Paton Rd / Tane Rd	-4.5%	A-C	A-C	Ok	-6.8%	A-C	A-C	Ok	0.2%	A-C	A-C	Ok	-0.2%	A-C	A-C	Ok	1.3%	A-C	A-C	Ok	-1.4%	A-C	A-C	Ok
1332	27	Te Puke Hwy / Welcome Bay Rd	6.6%	A-C	A-C	Ok	10.2%	A-C	A-C	Ok	2.7%	A-C	A-C	Ok	7.0%	A-C	A-C	Ok	6.5%	A-C	A-C	Ok	7.2%	E	A-C	Ok
1333	28	TEL Southern Roundabout at Domain Rd Interchange	-0.6%	A-C	A-C	Ok	-0.3%	A-C	A-C	Ok	-2.4%	A-C	A-C	Ok	0.8%	A-C	A-C	Ok	0.2%	A-C	A-C	Ok	-0.1%	E	A-C	Ok
1331	29	TEL Northern Roundabout at Domain Rd Interchange	0.4%	A-C	A-C	Ok	1.4%	A-C	A-C	Ok	-3.3%	A-C	A-C	Ok	-0.3%	A-C	A-C	Ok	-0.7%	A-C	A-C	Ok	-0.5%	A-C	A-C	Ok
2862	30	Te Okura Dr / The Boulevard	-6.7%	A-C	A-C	Ok	-9.4%	A-C	A-C	Ok	-4.1%	A-C	A-C	Ok	-4.9%	A-C	A-C	Ok	-4.0%	A-C	A-C	Ok	-3.7%	A-C	A-C	Ok

Appendix 10: Tiaki Consultants PEI Bridge Structural Assessment

Memo

To: Rod Bailey, Bell Road Ltd Partnership

From: Donald Richardson

Date: 10 April 2026

Project No. 26012

Subject: Papamoa East Interchange (PEI) Bridge
Potential for carrying additional traffic

Background

Bell Road Limited Partnership (BRLP) are progressing the substantive application for the Wairakei South FTA090 listed project located on the southern side of the Tauranga Eastern Link (TEL), adjacent to Papamoa East. As part of this project, Boffa Miskell are undertaking regional traffic modelling, which indicates that the Papamoa Eastern Interchange (PEI), presently under construction, will require an additional traffic lane in each direction to accommodate the additional vehicle demand.

The existing interchange configuration and two modification options — including one option providing a separate shared pedestrian and cycle bridge — are illustrated on the attached drawing.

This memorandum provides an initial assessment of the feasibility of accommodating the additional lanes within the current PEI footprint, including consideration of removing portions of the existing reinforced concrete bridge structure to create the necessary space for additional vehicle lanes.

Considerations

There are a couple of aspects that need consideration:

1. The ability of the bridge and foundations to take extra load.
2. The limiting geometry (width) of the bridge
3. The NZTA and Council standards required of the carriageway elements.

The current bridge configuration is shown on the attached drawing. The bridge is currently marked as having 5 x 3.5m wide trafficable lanes, 2 x 1.8m wide shoulders, a 3.0m wide shared path and a 2.0m wide footpath, with non-climbable concrete barriers.

Bridges are designed for traffic loading based on the width of the bridge between barriers. This bridge is approximately 29m wide, which could take up to 7 traffic loading lanes. There should be no structural reason for the bridge not to be able to take 6 lanes, as proposed.

Option 1

It is proposed to modify the current bridge configuration to allow an additional marked trafficable lane. The proposed arrangement is illustrated in Option 1 in the attached drawing. The compromises are:

- Removal of vehicle median
- Reduction in pedestrian and shared pathway widths from 2.0m to 1.5m and 3.0m to 1.5m, respectively. These are still within the allowances in the NZTA bridge manual.
- Reduction in shoulder width from 1.8m to 1.2m. Also, within NZTA allowances.
- Partial demolition of raised kerb to allow for increased vehicle lanes.

Geometrically, the updated lane layout, median and footpaths widths could work by adopting the minimum widths as given in the NZTA Bridge Manual.

In principle, the removal of the concrete as shown would not cause a structural problem. Suitable repairs would need to be undertaken, including the addition of reinforcing to replace that lost to the demolition process.

Option 2

Option 2 adds an additional vehicle lane and removes the raised median, reduces shoulder widths to 1.2m, and one footpath (3.0m width). The second footpath (shared path) on the bridge is removed but replaced by an independent shared path bridge of 4.6m width sharing the current bridge's abutment (this still needs strength checking but would fit geometrically).

Estimated cost of the independent bridge based on the shared abutment solution is ██████████. Note that this is an estimate for the additional shared path bridge only – no associated connectivity or costs for changes to the existing bridge.

Provisos

It must be qualified that limited design documentation for this bridge has been sighted, however there are a couple of relevant general design points to note:

1. All the main bridge beams making up the full carriageway width as shown on the drawings are the same in terms of geometry and the prestressing reinforcing provided, therefore would have the same strength.
2. The NZTA bridge manual design process for road bridges requires the bridge loading to be determined by the carriageway clear width of the bridge between barriers. This design width is filled with standard vehicle loads in a standard width traffic lane. The number of traffic lanes for a particular bridge width (and hence loading) is independent of what lines are painted on the road or location of kerb, and the position of the loads within each lane is such that it must create the worst load effect for the bridge. The bridge should therefore be designed to cope with any legal road layout and standard loading (HN HO 72).

Appendix 11: PEI Walking and Cycling Assessment

Cycle & Pedestrian Facility Summary

Cycle & Pedestrian Facility Summary – Do Min 2035

Traffic signal backing board width is about 625mm for dual 200mm lanterns. With 500mm clearance each side, a 1.6m wide island is assessed as an appropriate minimum.

Min design on bridge for:

- 50/50 directional split: 2.5m both sides
- 75/25 directional split: 2.5m both sides
- Austroads permits a 2.0m shared path in constrained circumstances



Wairakei South DM 2035 Traffic Demands		
Shared Path Network Location & Description	Cross Section Path Width	
	Side 1	Side 2
AM Peak		
Sands Ave - North of the PEI	2.5	2.5
Sands Ave - PEI Bridge	2.5	2.5
Sands Ave - South of the PEI	N/A	N/A
PM Peak		
Sands Ave - North of the PEI	3.0	2.5
Sands Ave - PEI Bridge	2.5	2.5
Sands Ave - South of the PEI	N/A	N/A
Shared Path Network Location & Description		
Shared Path Network Location & Description	Cross Section Path Width	
	Side 1	Side 2
AM Peak		
Sands Ave - North of the PEI	3.0	2.5
Sands Ave - PEI Bridge	2.5	2.5
Sands Ave - South of the PEI	N/A	N/A
PM Peak		
Sands Ave - North of the PEI	3.0	3.0
Sands Ave - PEI Bridge	2.5	2.5
Sands Ave - South of the PEI	N/A	N/A

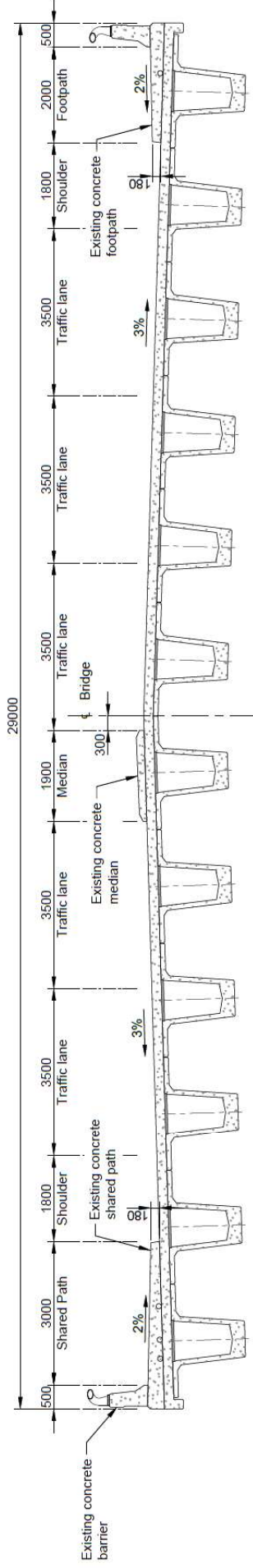

EXISTING LANE CONFIGURATION

Scale 1:100 on A3

Cycle & Pedestrian Facility Summary – up to 2035

Traffic signal backing board width is about 625mm for dual 200mm lanterns. With 500mm clearance each side, a 1.6m wide island is assessed as an appropriate minimum.

Min design on bridge for:

- 50/50 directional split: 2.5m both sides
- 75/25 directional split: 3.0m both sides

Wairakei South CS 2035 Traffic Demands		
Shared Path Network Location & Description	Cross Section Path Width	
	Proposed Side 1	Proposed Side 2
AM Peak		
Sands Ave - North of the PEI	2.5	2.5
Sands Ave - PEI Bridge	2.5	2.5
Sands Ave - South of the PEI	2.5	2.5
PM Peak		
Sands Ave - North of the PEI	3.0	2.5
Sands Ave - PEI Bridge	2.5	2.5
Sands Ave - South of the PEI	2.5	2.5
Shared Path Network Location & Description	Cross Section Path Width	
	Proposed Side 1	Proposed Side 2
AM Peak		
Sands Ave - North of the PEI	3.0	3.0
Sands Ave - PEI Bridge	3.0	2.5
Sands Ave - South of the PEI	2.5	2.5
PM Peak		
Sands Ave - North of the PEI	3.0	3.0
Sands Ave - PEI Bridge	3.0	3.0
Sands Ave - South of the PEI	3.0	2.5

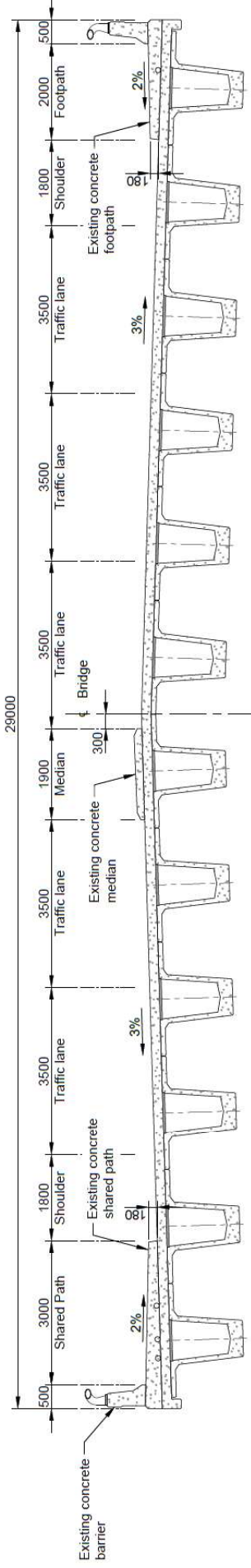

EXISTING LANE CONFIGURATION

Scale 1:100 on A3

Cycle & Pedestrian Facility Summary – up to 2048

Traffic signal backing board width is about 625mm for dual 200mm lanterns. With 500mm clearance each side, a 1.6m wide island is assessed as an appropriate minimum.

- Min design on bridge for:
- 50/50 directional split: 3.0m both sides
 - 75/25 directional split: 2.5 cycle lane (2-way) + 1.5 footpath one side + 3.0m other side

Below design for bridge is appropriate
 Separate structure is required – 4.0m min + 300mm clearance each side is recommended to edge rails

Wairakei South CS 2048 Traffic Demands		
Shared Path Network Location & Description	Cross Section Path Width Proposed	
	Side 1	Side 2
AM Peak		
Sands Ave - North of the PEI	3.0	2.5
Sands Ave - PEI Bridge	3.0	2.5
Sands Ave - South of the PEI	2.5	2.5
PM Peak		
Sands Ave - North of the PEI	3.0	3.0
Sands Ave - PEI Bridge	3.0	3.0
Sands Ave - South of the PEI	2.5	2.5
Shared Path Network Location & Description	Cross Section Path Width Proposed	
	Side 1	Side 2
AM Peak		
Sands Ave - North of the PEI	2.5C+1.5P	3.0
Sands Ave - PEI Bridge	2.5C+1.5P	3.0
Sands Ave - South of the PEI	3.0	3.0
PM Peak		
Sands Ave - North of the PEI	2.5C+1.5P	2.5C+1.5P
Sands Ave - PEI Bridge	2.5C+1.5P	3.0
Sands Ave - South of the PEI	3.0	3.0

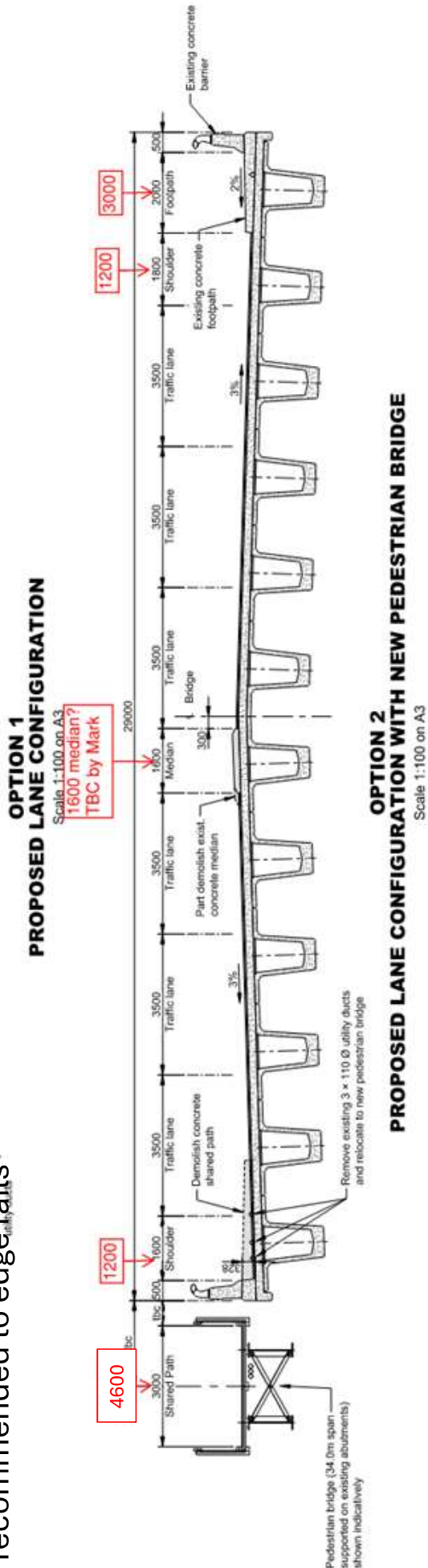

Cycle & Pedestrian Facility Summary – up to 2063

Traffic signal backing board width is about 625mm for dual 200mm lanterns. With 500mm clearance each side, a 1.6m wide island is assessed as an appropriate minimum.

- Min design on bridge for:
- 50/50 directional split: 3.0m both sides
 - 75/25 directional split: 2.5 cycle lane (2-way) + 1.5 footpath one side + 3.0m other side

Below design for bridge is appropriate
 Separate structure is required – 4.0m min + 300mm clearance each side is recommended to edge rails

Wairakei South CSS2 2063 long-term with PEI Bypass Traffic Demands			
Shared Path Network Location & Description	Cross Section Path Width Proposed	Side 2	
		Side 1	Side 2
AM Peak			
Sands Ave - North of the PEI	3.0	3.0	3.0
Sands Ave - PEI Bridge	3.0	2.5	2.5
Sands Ave - South of the PEI	2.5	2.5	2.5
PM Peak			
Sands Ave - North of the PEI	3.0	3.0	3.0
Sands Ave - PEI Bridge	3.0	3.0	3.0
Sands Ave - South of the PEI	3.0	2.5	2.5
Shared Path Network Location & Description			
Shared Path Network Location & Description	Cross Section Path Width Proposed	Side 2	
		Side 1	Side 2
AM Peak			
Sands Ave - North of the PEI	2.5C+1.5P	3.0	3.0
Sands Ave - PEI Bridge	2.5C+1.5P	3.0	3.0
Sands Ave - South of the PEI	3.0	3.0	3.0
PM Peak			
Sands Ave - North of the PEI	2.5C+1.5P	2.5C+1.5P	2.5C+1.5P
Sands Ave - PEI Bridge	2.5C+1.5P	3.0	3.0
Sands Ave - South of the PEI	3.0	3.0	3.0

OPTION 1 PROPOSED LANE CONFIGURATION

Scale 1:100 on A3

1600 median?
TBC by Mark

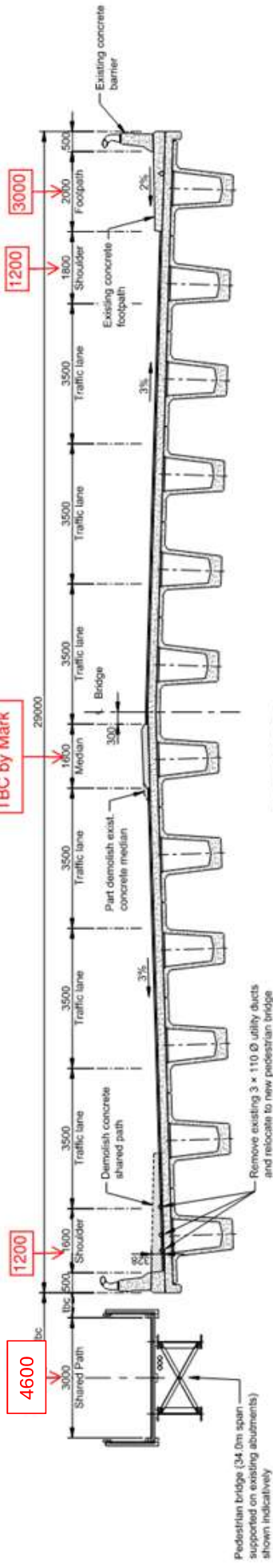

OPTION 2 PROPOSED LANE CONFIGURATION WITH NEW PEDESTRIAN BRIDGE

Scale 1:100 on A3

Guide to Road Design Part 6A: Paths for Walking and Cycling

- F** Major recreation
- High and concurrent use in both directions
 - 20 km/h

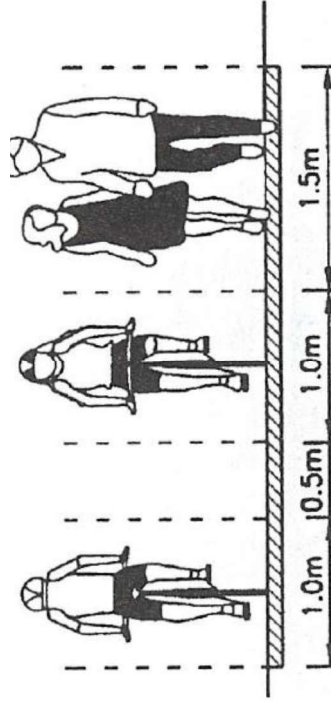

4.0 m

Figure 5.7: Clearances between cyclist envelope and potential path hazards

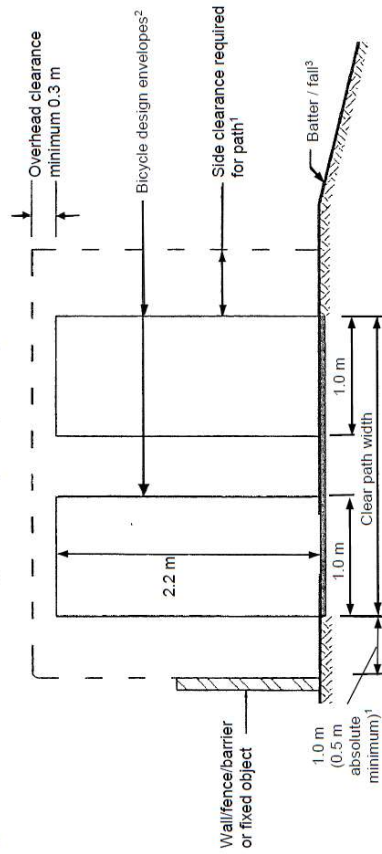

- ¹ This may be reduced to 0.3 m where a fence or obstacle has smooth features.
- ² Refer to Section 3.2.2 for guidance on bicycle design envelopes.
- ³ Refer to Section 5.5.3 for guidance on batters and need for a fence.

The following guidelines should be applied for clearances between the cyclist operating spaces and potential hazards beside paths:

- Where the areas beside the path and the path alignment are both relatively flat a lateral clearance of at least 1.0 m (0.5 m absolute minimum) should be provided between the edge of any path for cycling and any obstacle, which if struck may result in cyclists losing control or being injured. However, on high-speed paths it is most desirable to have a clearance considerably greater than 1.0 m. This is particularly important on small radius horizontal curves where cyclists may lean in when travelling around the curve.
- Where it is considered that an obstacle or hazard beside the path has attributes that could cause serious injury to cyclists (e.g. sharp surfaces such as the rear side of the posts and rails of steel W-beam road safety barrier), designers should assess the risk of cyclists losing control on the particular section of path, and consider either increasing the lateral clearance or shielding cyclists from the hazard. Depending on the situation a rub rail behind the posts or a cyclist fence near the edge of the path could be provided.
- Where a vertical drop or a steep batter exists or must be provided adjacent to the path the guidance in Section 5.5.2 should be applied.

Obstacles beside paths include bushes, culvert end walls, trees and large rocks used in landscaping. Provided the design and end treatments are appropriate, or where extenuating circumstances exist, a lesser clearance may be acceptable for fences and other obstacles that have smooth features and are aligned parallel to the path (0.3 m absolute minimum).

Appendix D – Technical Evaluations

Summary Evaluation Pedestrian and Cycle Facilities
Austrroads Guide to Road Design Part 6A: S5.1.3 Bicycle Paths

Wairakei South DM 2035 Traffic Demands

Shared Path Network Location & Description	Cross Section Path Width Proposed	
	Side 1	Side 2
AM Peak		
Sands Ave - North of the PEI	2.5	2.5
Sands Ave - PEI Bridge	2.5	2.5
Sands Ave - South of the PEI	N/A	N/A
PM Peak		
Sands Ave - North of the PEI	3.0	2.5
Sands Ave - PEI Bridge	2.5	2.5
Sands Ave - South of the PEI	N/A	N/A

Shared Path Network Location & Description	Cross Section Path Width Proposed	
	Side 1	Side 2
AM Peak		
Sands Ave - North of the PEI	3.0	2.5
Sands Ave - PEI Bridge	2.5	2.5
Sands Ave - South of the PEI	N/A	N/A
PM Peak		
Sands Ave - North of the PEI	3.0	3.0
Sands Ave - PEI Bridge	2.5	2.5
Sands Ave - South of the PEI	N/A	N/A

Wairakei South CS 2035 Traffic Demands

Shared Path Network Location & Description	Cross Section Path Width Proposed	
	Side 1	Side 2
AM Peak		
Sands Ave - North of the PEI	2.5	2.5
Sands Ave - PEI Bridge	2.5	2.5
Sands Ave - South of the PEI	2.5	2.5
PM Peak		
Sands Ave - North of the PEI	3.0	2.5
Sands Ave - PEI Bridge	2.5	2.5
Sands Ave - South of the PEI	2.5	2.5

Shared Path Network Location & Description	Cross Section Path Width Proposed	
	Side 1	Side 2
AM Peak		
Sands Ave - North of the PEI	3.0	3.0
Sands Ave - PEI Bridge	3.0	2.5
Sands Ave - South of the PEI	2.5	2.5
PM Peak		
Sands Ave - North of the PEI	3.0	3.0
Sands Ave - PEI Bridge	3.0	3.0
Sands Ave - South of the PEI	3.0	2.5

Wairakei South CS 2048 Traffic Demands

Shared Path Network Location & Description	Cross Section Path Width Proposed	
	Side 1	Side 2
AM Peak		
Sands Ave - North of the PEI	3.0	2.5
Sands Ave - PEI Bridge	3.0	2.5
Sands Ave - South of the PEI	2.5	2.5
PM Peak		
Sands Ave - North of the PEI	3.0	3.0
Sands Ave - PEI Bridge	3.0	3.0
Sands Ave - South of the PEI	2.5	2.5

Shared Path Network Location & Description	Cross Section Path Width Proposed	
	Side 1	Side 2
AM Peak		
Sands Ave - North of the PEI	2.5C+1.5P	3.0
Sands Ave - PEI Bridge	2.5C+1.5P	3.0
Sands Ave - South of the PEI	3.0	3.0
PM Peak		
Sands Ave - North of the PEI	2.5C+1.5P	2.5C+1.5P
Sands Ave - PEI Bridge	2.5C+1.5P	3.0
Sands Ave - South of the PEI	3.0	3.0

Wairakei South CSS2 2063 long-term with PEI Bypass Traffic Demands

Shared Path Network Location & Description	Cross Section Path Width Proposed	
	Side 1	Side 2
AM Peak		
Sands Ave - North of the PEI	3.0	3.0
Sands Ave - PEI Bridge	3.0	2.5
Sands Ave - South of the PEI	2.5	2.5
PM Peak		
Sands Ave - North of the PEI	3.0	3.0
Sands Ave - PEI Bridge	3.0	3.0
Sands Ave - South of the PEI	3.0	2.5

Shared Path Network Location & Description	Cross Section Path Width Proposed	
	Side 1	Side 2
AM Peak		
Sands Ave - North of the PEI	2.5C+1.5P	3.0
Sands Ave - PEI Bridge	2.5C+1.5P	3.0
Sands Ave - South of the PEI	3.0	3.0
PM Peak		
Sands Ave - North of the PEI	2.5C+1.5P	2.5C+1.5P
Sands Ave - PEI Bridge	2.5C+1.5P	3.0
Sands Ave - South of the PEI	3.0	3.0

Figure 5.4: Path widths for a 50/50 directional split

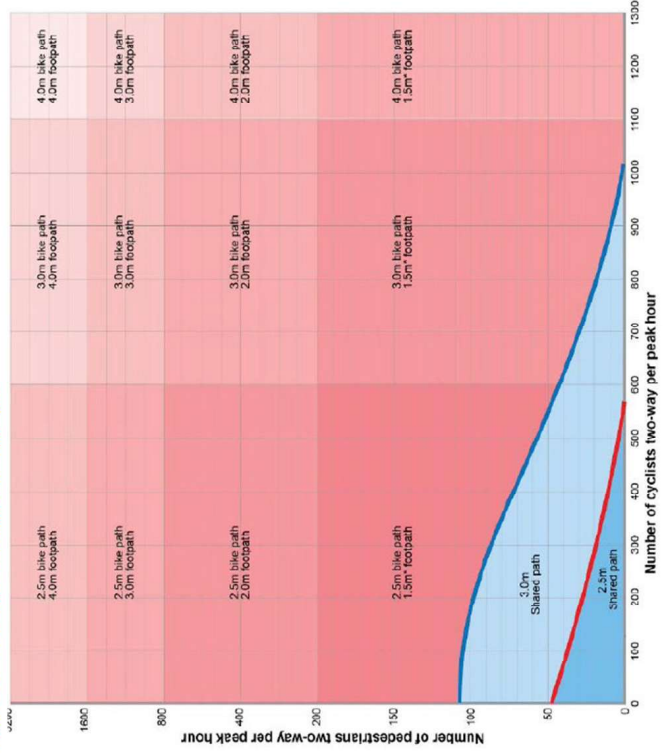
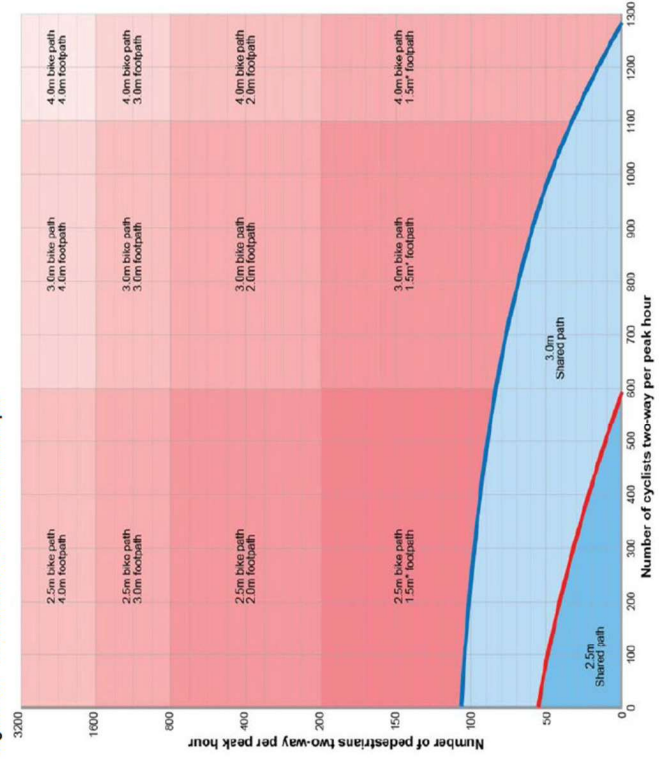

Figure 5.5: Path widths for a 75/25 directional split



Summary Evaluation Pedestrian and Cycle Facilities
Austroroads Guide to Road Design Part 6A: 55.1.3 Bicycle Paths
Wairakei South DM 2035 Traffic Demands

Shared Path Network Location & Description	Cross Section Path Width Proposed		CSS2 Peak Vehicle Demands (Two Way Total)	Cycle Mode Share %	Pedestrian Mode Share %	Peak Hour Movement Demand (Two-Way Total) Cycles	Path Movement Demands (Two-Way Total) - 50/50 Split		Austroroads Path Width Requirement (m) - 50/50		Compliance
	Side 1	Side 2					Side 1	Side 2	Side 1	Side 2	
AM Peak											
Sands Ave - North of the PEI	2.5	2.5	1614	7.5%	2.5%	121	61	20	2.5	2.5	Yes
Sands Ave - PEI Bridge	2.5	2.5	686	7.5%	2.5%	51	26	9	2.5	2.5	Yes
Sands Ave - South of the PEI	N/A	N/A	N/A	7.5%	2.5%	N/A	N/A	N/A	N/A	N/A	Yes
PM Peak											
Sands Ave - North of the PEI	3.0	2.5	1957	7.5%	2.5%	147	73	24	2.5	3.0	Yes
Sands Ave - PEI Bridge	2.5	2.5	1070	7.5%	2.5%	80	40	13	2.5	2.5	Yes
Sands Ave - South of the PEI	N/A	N/A	N/A	7.5%	2.5%	N/A	N/A	N/A	N/A	N/A	Yes
Shared Path Network Location & Description											
	Cross Section Path Width Proposed		CSS2 Peak Vehicle Demands (Two Way Total)	Cycle Mode Share %	Pedestrian Mode Share %	Peak Hour Movement Demand (Two-Way Total) Cycles	Path Movement Demands (Two-Way Total) - 50/50 Split		Austroroads Path Width Requirement (m) - 50/50		Compliance
	Side 1	Side 2					Side 1	Side 2	Side 1	Side 2	
AM Peak											
Sands Ave - North of the PEI	3.0	2.5	1614	10%	5%	161	81	40	2.5	2.5	Yes
Sands Ave - PEI Bridge	2.5	2.5	686	10%	5%	69	34	17	2.5	2.5	Yes
Sands Ave - South of the PEI	N/A	N/A	N/A	10%	5%	N/A	N/A	N/A	N/A	N/A	Yes
PM Peak											
Sands Ave - North of the PEI	3.0	3.0	1957	10%	5%	196	98	49	3.0	3.0	Yes
Sands Ave - PEI Bridge	2.5	2.5	1070	10%	5%	107	54	27	2.5	2.5	Yes
Sands Ave - South of the PEI	N/A	N/A	N/A	10%	5%	N/A	N/A	N/A	N/A	N/A	Yes

Figure 5.4: Path widths for a 50/50 directional split

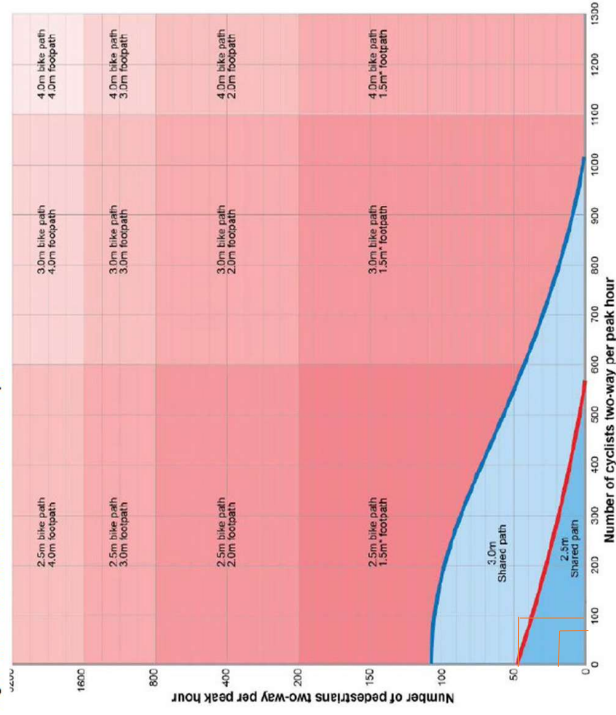
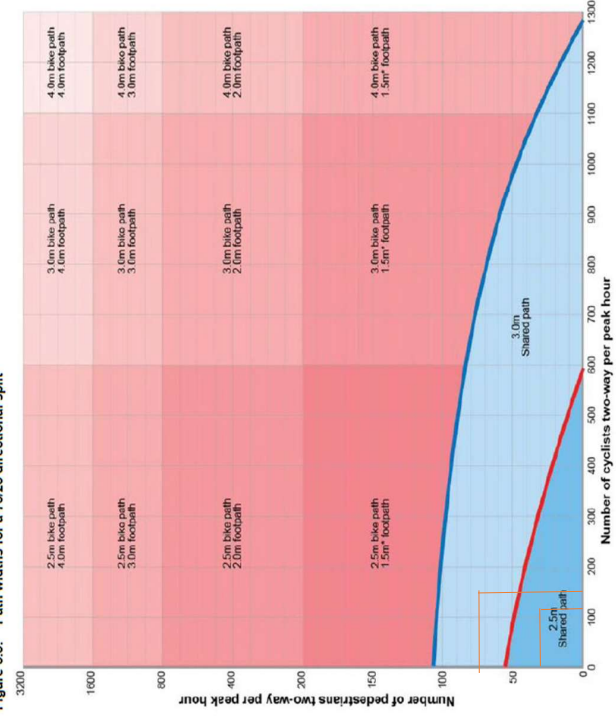

Figure 5.5: Path widths for a 75/25 directional split



Summary Evaluation Pedestrian and Cycle Facilities
Austroroads Guide to Road Design Part 6A: 55.1.3 Bicycle Paths
Wairakei South CS 2035 Traffic Demands

Shared Path Network Location & Description	Cross Section Path Width Proposed		CSS2 Peak Vehicle Demands (Two Way Total)	Cycle Mode Share %	Pedestrian Mode Share %	Peak Hour Movement Demand (Two-Way Total) Cycles	Path Movement Demands (Two-Way Total) - 50/50 Split		Austroroads Path Width Requirement (m) - 50/50		Compliance	
	Side 1	Side 2					Side 1	Side 2	Side 1	Side 2		
	Cycles Pedestrians Cycles Pedestrians						Cycles Pedestrians Cycles Pedestrians					
AM Peak												
Sands Ave - North of the PEI	2.5	2.5	2212	7.5%	2.5%	166	83	28	83	2.5	2.5	Yes
Sands Ave - PEI Bridge	2.5	2.5	1559	7.5%	2.5%	39	58	19	58	2.5	2.5	Yes
Sands Ave - South of the PEI	2.5	2.5	1149	7.5%	2.5%	86	29	43	14	2.5	2.5	Yes
PM Peak												
Sands Ave - North of the PEI	3.0	2.5	2722	7.5%	2.5%	204	102	34	102	3.0	2.5	Yes
Sands Ave - PEI Bridge	2.5	2.5	2149	7.5%	2.5%	161	54	81	27	2.5	2.5	Yes
Sands Ave - South of the PEI	2.5	2.5	1443	7.5%	2.5%	108	36	54	18	2.5	2.5	Yes
Shared Path Network Location & Description	Cross Section Path Width Proposed		CSS2 Peak Vehicle Demands (Two Way Total)	Cycle Mode Share %	Pedestrian Mode Share %	Peak Hour Movement Demand (Two-Way Total) Cycles	Path Movement Demands (Two-Way Total) - 50/50 Split		Austroroads Path Width Requirement (m) - 50/50		Compliance	
	Side 1	Side 2					Side 1	Side 2	Side 1	Side 2		
	Cycles Pedestrians Cycles Pedestrians						Cycles Pedestrians Cycles Pedestrians		Cycles Pedestrians Cycles Pedestrians			
AM Peak												
Sands Ave - North of the PEI	3.0	3.0	2212	10%	5%	221	111	55	111	3.0	3.0	Yes
Sands Ave - PEI Bridge	3.0	2.5	1559	10%	5%	156	78	39	78	2.5	2.5	Yes
Sands Ave - South of the PEI	2.5	2.5	1149	10%	5%	115	57	29	57	2.5	2.5	Yes
PM Peak												
Sands Ave - North of the PEI	3.0	3.0	2722	10%	5%	272	136	68	136	3.0	3.0	Yes
Sands Ave - PEI Bridge	3.0	3.0	2149	10%	5%	215	107	54	107	3.0	3.0	Yes
Sands Ave - South of the PEI	3.0	2.5	1443	10%	5%	144	72	36	72	2.5	2.5	Yes

Figure 5.4: Path widths for a 50/50 directional split

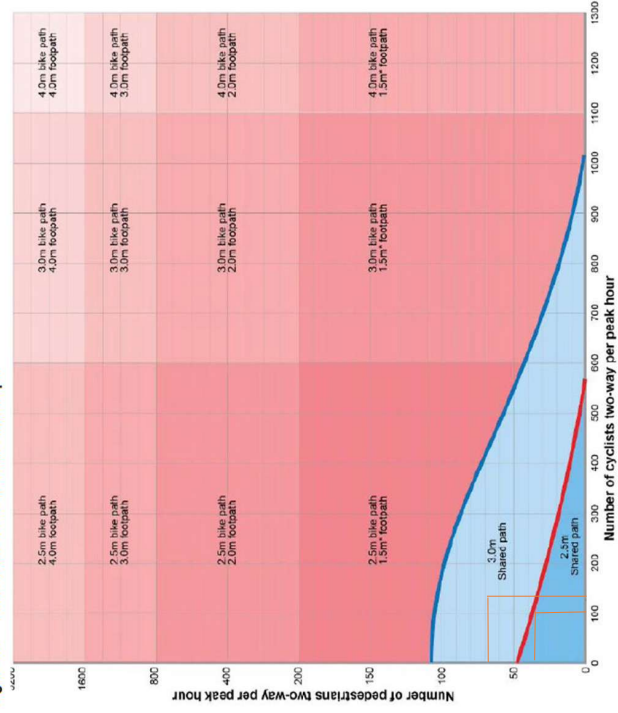
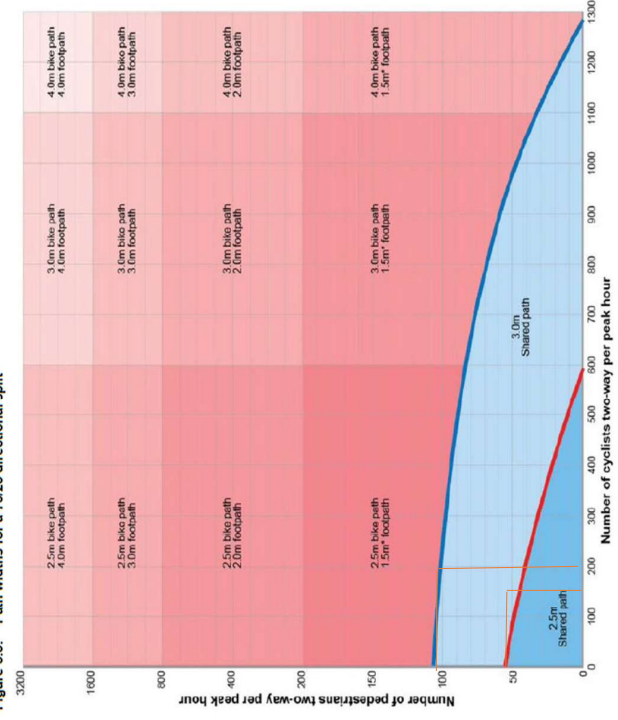

Figure 5.5: Path widths for a 75/25 directional split



Summary Evaluation Pedestrian and Cycle Facilities
Austroroads Guide to Road Design Part 6A: 55.1.3 Bicycle Paths
Wairakei South CS 2048 Traffic Demands

Shared Path Network Location & Description	Cross Section Path Width Proposed		CSS2 Peak Vehicle Demands (Two Way Total)	Pedestrian Mode Share %	Peak Hour Movement Demand (Two-Way Total) Cycles	Path Movement Demands (Two-Way Total) - 50/50 Split		Austroroads Path Width Requirement (m) - 50/50		Compliance					
	Side 1 (West)	Side 2 (East)				Side 1 (West)	Side 2 (East)	Side 1 (West)	Side 2 (East)						
											Cycles Pedestrians	Cycles Pedestrians			
AM Peak															
Sands Ave - North of the PEI	3.0	2.5	3631	7.5%	272	91	136	45	136	45	3.0	3.0	3.0	2.5	Yes
Sands Ave - PEI Bridge	3.0	2.5	2502	7.5%	188	63	94	31	94	31	2.5	2.5	2.5	2.5	Yes
Sands Ave - South of the PEI	2.5	2.5	2146	7.5%	161	54	80	27	80	27	2.5	2.5	2.5	2.5	Yes
PM Peak															
Sands Ave - North of the PEI	3.0	3.0	4364	7.5%	327	109	164	55	164	55	3.0	3.0	3.0	3.0	Yes
Sands Ave - PEI Bridge	3.0	3.0	3214	7.5%	241	80	121	40	121	40	3.0	3.0	3.0	3.0	Yes
Sands Ave - South of the PEI	2.5	2.5	2122	7.5%	159	53	80	27	80	27	2.5	2.5	2.5	2.5	Yes
Shared Path Network Location & Description	Cross Section Path Width Proposed		CSS2 Peak Vehicle Demands (Two Way Total)	Pedestrian Mode Share %	Peak Hour Movement Demand (Two-Way Total) Cycles	Path Movement Demands (Two-Way Total) - 50/50 Split		Austroroads Path Width Requirement (m) - 50/50		Compliance					
	Side 1 (West)	Side 2 (East)				Side 1 (West)	Side 2 (East)	Side 1 (West)	Side 2 (East)						
						Cycles Pedestrians	Cycles Pedestrians								
AM Peak															
Sands Ave - North of the PEI	2.5C+1.5P	3.0	3631	10%	363	182	91	182	91	45	2.5C+1.5P	2.5	2.5	2.5	Yes
Sands Ave - PEI Bridge	2.5C+1.5P	3.0	2502	10%	250	125	63	125	63	31	2.5C+1.5P	2.5	2.5	2.5	Yes
Sands Ave - South of the PEI	3.0	3.0	2146	10%	215	107	54	107	54	27	3.0	3.0	3.0	3.0	Yes
PM Peak															
Sands Ave - North of the PEI	2.5C+1.5P	2.5C+1.5P	4364	10%	436	218	109	218	109	109	2.5C+1.5P	3.0	3.0	3.0	Yes
Sands Ave - PEI Bridge	2.5C+1.5P	3.0	3214	10%	321	161	80	161	80	40	2.5C+1.5P	2.5	2.5	2.5	Yes
Sands Ave - South of the PEI	3.0	3.0	2122	10%	212	106	53	106	53	27	3.0	3.0	3.0	3.0	Yes

Figure 5.4: Path widths for a 50/50 directional split

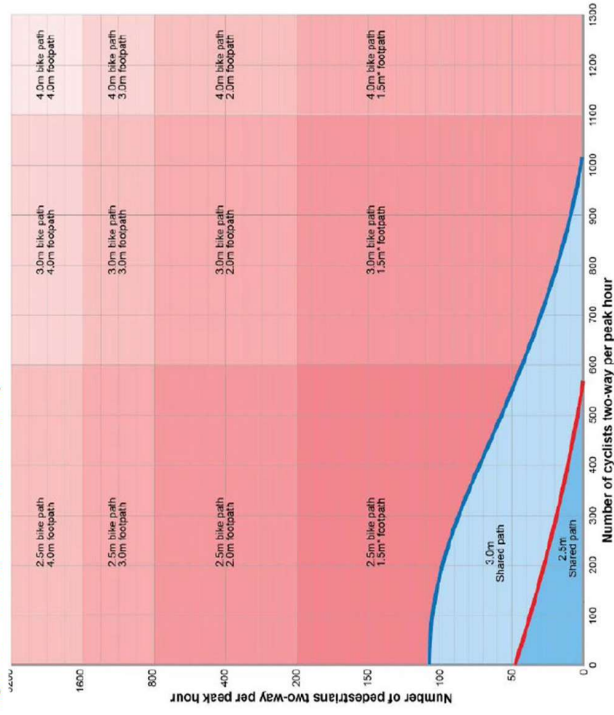
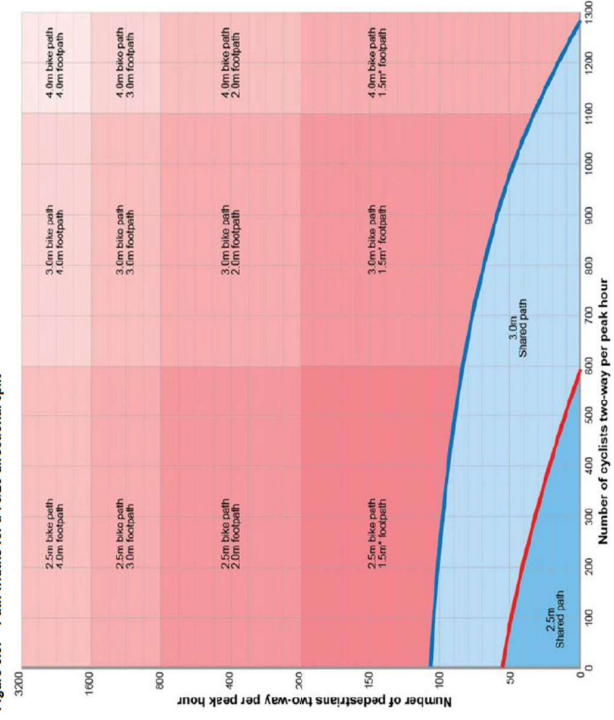

Figure 5.5: Path widths for a 75/25 directional split



Summary Evaluation Pedestrian and Cycle Facilities

Austrorads Guide to Road Design Part 6A: SS.1.3 Bicycle Paths

Wairakei South CSS2 2063 long-term with PEI Bypass Traffic Demands

Shared Path Network Location & Description	Cross section Path Width Proposed				Peak Hour Movement Demand (Two-Way Total)		Path Movement Demands (Two-Way Total) - 50/50 Split		Austrorads Path Width Requirement (m) - 50/50		Compliance	
	Side 1 (West)		Side 2 (East)		Cycles	Pedestrians	Side 1 (West)	Side 2 (East)	Side 1 (West)	Side 2 (East)	Side 1 (West)	Side 2 (East)
	Side 1 (West)	Side 2 (East)	Cycle Mode Share %	Pedestrian Mode Share %	Cycles	Pedestrians	Cycles	Pedestrians	Cycles	Pedestrians	Cycles	Pedestrians
AM Peak												
Sands Ave - North of the PEI	3.0	3.0	7.5%	2.5%	280	93	140	47	140	47	3	3
Sands Ave - PEI Bridge	3.0	2.5	7.5%	2.5%	208	69	104	35	104	35	2.5	2.5
Sands Ave - South of the PEI	2.5	2.5	7.5%	2.5%	140	47	70	23	70	23	2.5	2.5
PM Peak												
Sands Ave - North of the PEI	3.0	3.0	7.5%	2.5%	340	113	170	57	170	57	3	3
Sands Ave - PEI Bridge	3.0	3.0	7.5%	2.5%	272	91	136	45	136	45	3	3
Sands Ave - South of the PEI	3.0	2.5	7.5%	2.5%	164	55	82	27	82	27	2.5	2.5
BOP Regional Council Mode Share Target - 13%												
Shared Path Network Location & Description	Cross section Path Width Proposed		Cycle Mode Share %	Pedestrian Mode Share %	Peak Hour Movement Demand (Two-Way Total)		Path Movement Demands (Two-Way Total) - 50/50 Split		Austrorads Path Width Requirement (m) - 50/50		Compliance	
	Side 1 (West)	Side 2 (East)			Cycles	Pedestrians	Side 1 (West)	Side 2 (East)	Side 1 (West)	Side 2 (East)	Side 1 (West)	Side 2 (East)
AM Peak												
Sands Ave - North of the PEI	2.5C+1.5P	3.0	9%	4%	336	149	168	75	168	75	3	3
Sands Ave - PEI Bridge	2.5C+1.5P	3.0	7%	4%	250	111	125	56	125	56	3	3
Sands Ave - South of the PEI	3.0	3.0	9%	4%	168	75	84	37	84	37	3	3
PM Peak												
Sands Ave - North of the PEI	2.5C+1.5P	2.5C+1.5P	9%	4%	408	181	204	91	204	91	2.5C+1.5P	2.5C+1.5P
Sands Ave - PEI Bridge	2.5C+1.5P	3.0	9%	4%	327	145	163	73	163	73	3	3
Sands Ave - South of the PEI	3.0	3.0	9%	4%	196	87	98	44	98	44	3	3
Shared Path Network Location & Description	Cross section Path Width Proposed		Cycle Mode Share %	Pedestrian Mode Share %	Peak Hour Movement Demand (Two-Way Total)		Path Movement Demands (Two-Way Total) - 50/50 Split		Austrorads Path Width Requirement (m) - 50/50		Compliance	
	Side 1 (West)	Side 2 (East)			Cycles	Pedestrians	Side 1 (West)	Side 2 (East)	Side 1 (West)	Side 2 (East)	Side 1 (West)	Side 2 (East)
AM Peak												
Sands Ave - North of the PEI	2.5C+1.5P	3.0	10%	5%	373	187	187	93	187	93	3	3
Sands Ave - PEI Bridge	2.5C+1.5P	3.0	10%	5%	278	139	139	69	139	69	3	3
Sands Ave - South of the PEI	3.0	3.0	10%	5%	187	93	93	47	93	47	3	3
PM Peak												
Sands Ave - North of the PEI	2.5C+1.5P	2.5C+1.5P	10%	5%	453	227	227	113	227	113	2.5C+1.5P	2.5C+1.5P
Sands Ave - PEI Bridge	2.5C+1.5P	3.0	10%	5%	363	181	181	91	181	91	3	3
Sands Ave - South of the PEI	3.0	3.0	10%	5%	218	109	109	55	109	55	3	3

Figure 5.4: Path widths for a 50/50 directional split

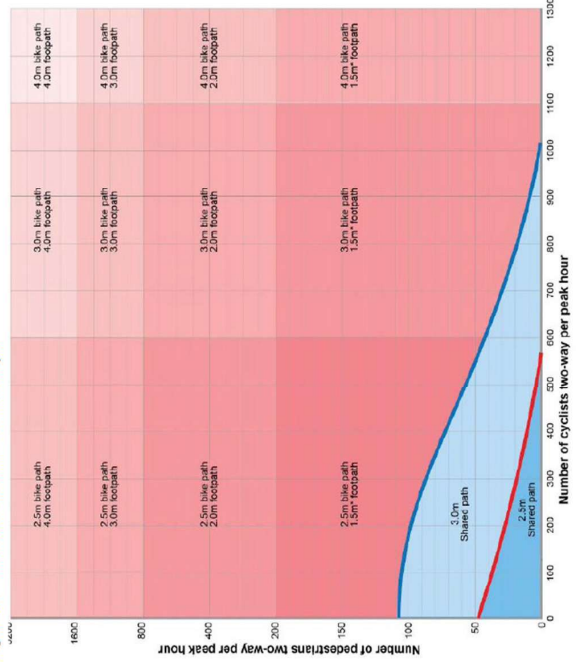
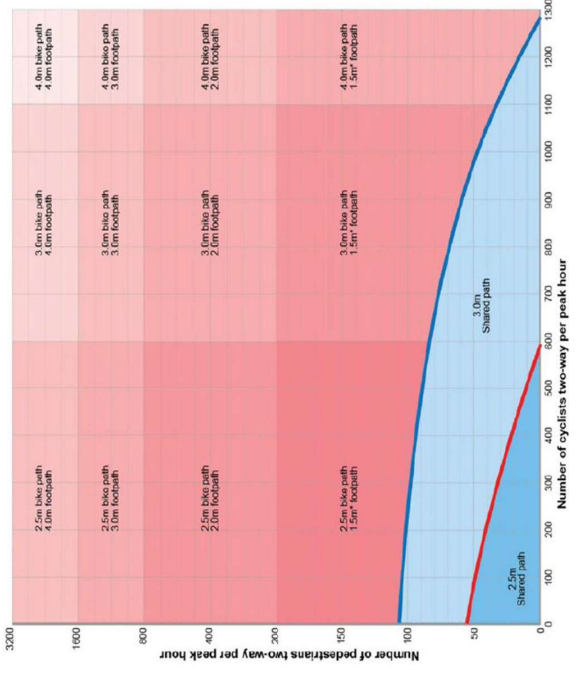

Figure 5.5: Path widths for a 75/25 directional split



Appendix 12: Level Crossing Safety Assessment

19 February 2026

Bell Road

Level Crossing Safety Impact Assessment

Prepared for / **Boffa Miskell Limited**

Project No. / **V-1871**

Revision / 01

Vitruvius / give it strength
make it useful
deliver it beautifully

Document Control Record

Document prepared by:

VITRUVIUS LIMITED



143 Durham Street, Tauranga
3110

+64 (4) 595 4708
info@vitruvius.co.nz
www.vitruvius.co.nz

Revision History

Rev	Date	Implemented By	Purpose/Change
01	20/02/2026	Shania Rajanayagam	For Information
	Select Date		
	Select Date		
	Select Date		

Sign Off

		Signature
Prepared By	Shania Rajanayagam	
	Rail Engineer	
	17-Feb-2026	
Verified By	Nigel Holman	
	Transport Service Leader	
	19-Feb-2026	
Approved By	Charlie Sherratt	
	Business Leader - Tauranga	
	20-Feb-2026	

Transmittal/Distribution

Date of Issue	To	To	To	Reason ¹
20/02/26	Boffa Miskel			For client review and approval
Select Date				

A person using Vitruvius documents or data accepts the risk of:

- Using the documents or data in electronic form without requesting and checking them for accuracy against the original hard copy version.
- Using the documents or data for any purpose not agreed to in writing by Vitruvius.
- Modification and / or distribution of this document for any purpose without the prior written consent of Vitruvius is strictly prohibited.

¹ Comment, Review, Draft, Approval, Final, As Requested, Copies for Distribution

Contents

Sections

1	Executive Summary	1
1.1	Background	1
1.2	Top-Down Evaluation	2
1.3	Bell Road LCSS	3
1.4	Bell Road Discussion	5
1.5	Recommended Level Crossing Improvements	6
1.6	Recommended Updates in ALCAM	6
2	Glossary	7
3	Introduction	8
3.1	Level Crossing Safety Impact Assessment	8
3.2	LCSIA Criteria	8
3.3	Structure of the report	8
4	Background	9
4.1	Brief project outline	9
4.2	Key Assumptions	10
4.3	Documents provided	10
4.4	Site Visits	11
4.5	LCSIA Assessor independence	11
4.6	Top-Down evaluation	11
5	Bell Road LCSIA.....	13
5.1	Existing Conditions at the Level Crossing	13
5.2	Key Existing Safety Issues	18
5.3	Proposed Design	18
5.4	ALCAM Updates in LXM	19
5.5	Traffic Volumes and Speed Inputs	21
5.6	ALCAM Score	22
5.7	Crash and Incident History Score	25
5.8	Site Specific Safety Score	26
5.9	Engineers' Score	35
5.10	Level Crossing Safety Score	36
5.11	Recommendations	41
5.12	Discussion	42
5.13	Recommended Improvements	43

Appendices

A Signal and Interlocking Plan

B Boffa Miskell Limited ADT Plots

Figures

Figure 5-1:	Bell Road level crossing (source: Western Bay of Plenty District Council)	14
Figure 5-2:	Surrounding context of the level crossing (source: Western Bay of Plenty District Council)	14
Figure 5-3:	Level crossing separation distance to intersection (source: Western Bay of Plenty District Council)	15
Figure 5-4:	Eastern approach surface rutting (source: Google Maps)	15
Figure 5-5:	Western approach surface rutting (source: Google Maps)	15
Figure 5-6:	Level crossing surface flange gaps (source: Google Maps)	16
Figure 5-7:	Eastern approach FLB (source: Google Maps)	16
Figure 5-8:	Western approach FLBs (source: Google Maps)	16
Figure 5-9:	Eastern approach sightlines to the north (source: Google Maps)	17
Figure 5-10:	Eastern approach sightlines to the south (source: Google Maps)	17
Figure 5-11:	Western approach sightlines to the north (source: Google Maps)	17
Figure 5-12:	Western approach sightlines to the south (source: Google Maps)	17
Figure 5-13:	Easter approach WX1L	17
Figure 5-14:	Western approach WX1L and WX1R	17
Figure 5-15:	Proposed design signalised intersection (source: Boffa Miskell)	19

Tables

Table 1-1:	Top-down evaluation of the Bel Road level crossing	2
Table 1-2:	LCSS for the Bell Road level crossing	3
Table 1-3:	LCSIA assessor recommendations for the Bell Road level crossing	4
Table 1-4:	Summary of ALCAM changes at Bell Road level crossing	5
Table 4-1:	Location of level crossing(s) in this LCSIA report	9
Table 4-2:	Top-down evaluation of the Bell Road level crossing	11
Table 5-1:	Existing conditions at the Bell Road level crossing	13
Table 5-2:	Risk assessment inputs	21
Table 5-3:	ALCAM risk score	22
Table 5-4:	10-year crash data from 2015 – 2026	25

Table 5-5: Crash and incident history score 25
Table 5-6: SSSS for the Bell Road level crossing 27
Table 5-7: LCSS for the Bell Road level crossing 36
Table 5-8: Bell Road level crossing key recommendation 41

1 Executive Summary

1.1 BACKGROUND

Vitruvius Limited has been engaged to prepare a Level Crossing Safety Impact Assessment (LCSIA) for the Bell Road level crossing, located adjacent to Te Puke Highway, Te Puke. This commission follows correspondence from Boffa Miskell to prepare a desktop draft LCSIA to support the Traffic Impact Assessment for the Wairakei South Fast Track consent application.

The LCSIA has been prepared to support the consent application, where the proposed development is expected to introduce changes to traffic demands crossing the railway over time. A planning assessment has identified that the scale and staging of the proposed development trigger the need for assessment in accordance with KiwiRail's Level Crossing Risk Assessment Guidance (LCRAG), and that level crossing safety is likely to be a key consideration during the consent process.

This LCSIA has been undertaken as a desktop assessment only, commissioned solely to inform the consent application and associated decision-making. In accordance with instructions, KiwiRail and Western Bay of Plenty District Council have not been engaged in the preparation of this assessment at this stage, noting that construction of the proposed development is not expected to commence until 2029 at the earliest.

This assessment has been prepared for information purposes only and is not considered a formal LCSIA. The analysis and scores presented are based on desktop assessment and preliminary assumptions. Further collaboration with KiwiRail locomotive engineers and the Road Controlling Authority (RCA) engineer is required to confirm operational considerations, validate assumptions, and finalise ALCAM and LCSS inputs prior to any formal LCSIA submission or progression through the SFAIRP process.

The purpose of the LCSIA is to:

- Assess the current and future safety risk at the Bell Road level crossing.
- Identify the extent of any change in risk associated with the proposed development.
- Inform whether staged mitigation measures may be required to support future traffic demands.

This LCSIA assesses the following scenarios:

- **Do Min:** Do Minimum for Wairakei South For 2048 and 2063: TTSM 2023 DM network and without Pāpāmoa East Interchange (PEI) bypass ramp in East Bound direction and Bell Road Connection to Te Tumu. For model years 2035, 2048, and 2063.
- **Core Scenario (CS):** Core Scenario with staged Wairakei South development, redistribution of Growth Areas and with Te Tumu development. For model years 2035, 2048, and 2063.
- **Sensitivity Test 1 (ST1):** Sensitivity Test with staged Wairakei South development, redistribution of Growth Areas and without Te Tumu development. For model years 2035, 2048, and 2063.
- **Option 10A:** Sensitivity Test1 with full Wairakei South development, redistribution of Growth Areas and without Te Tumu development. For model year 2048.
- **Comprehensive Sensitivity Scenario 1 (CSS1):** Comprehensive Sensitivity Scenario with the PEI bypass ramp in East Bound direction to Te Tumu. For model years 2048, and 2063.
- **Comprehensive Sensitivity Scenario 2 (CSS2):** Comprehensive Sensitivity Scenario with PEI bypass ramp in East Bound direction and Bell Road Connection to Te Tumu. For model years 2048, and 2063.

1.2 TOP-DOWN EVALUATION

As WBoPDC could not be contacted, the top-down evaluation has been completed by the LCSIA assessor and should be validated by WBoPDC. The evaluation is summarised in Table 1-1 below.

Table 1-1: Top-down evaluation of the Bel Road level crossing

<p>1. Can the level crossing be closed? What are the reasons the road controlling authority (RCA) has for pursuing/not pursuing this option?</p>	<p>It is not reasonably practicable to close the crossing as the crossing provides an existing connection between Bell Road and Te Puke Highway and is required to support current and future traffic movements associated with the surrounding road network. The proposed Wairakei South development is expected to increase traffic demands over time, reinforcing the functional role of the crossing rather than reducing it.</p>
<p>2. Can an existing level crossing on the same network be closed? What are the reasons the RCA has for pursuing/not pursuing this option?</p>	<p>It is not reasonably practicable to close another level crossing as the crossing as the nearest level crossings on the same rail network are located more than 4 km to the north and south of the Bell Road level crossing. As such, there are no nearby level crossings that could reasonably be closed to offset or substitute for the continued operation of the Bell Road crossing. Given the distance to the nearest alternative crossings, closure of another level crossing would not provide a practical or effective mitigation for the safety risks associated with the Bell Road level crossing, nor would it maintain appropriate connectivity for the local and strategic road network. Accordingly, closure of an alternative level crossing is not considered a reasonably practicable option as part of this assessment.</p>
<p>3. Can the level crossing be grade separated? What are the reasons the RCA has for pursuing /not pursuing this option?</p>	<p>It is not reasonably practicable to grade separate the crossing as grade separation would represent a significant infrastructure intervention, including relocation of the existing road alignments due to the proximity of the railway to the highway and surround landform. requiring detailed investigation, design development, land requirements and acquisition and engagement with KiwiRail and the WBoPDC. Such matters fall outside the scope and intent of this desktop assessment, which is focused on understanding safety risk changes over time and identifying whether staged mitigation measures may be required to support the proposed development.</p>

1.3 BELL ROAD LCSS

The Bell Road Level Crossing Safety Score (LCSS) is noted in Table 1-2 below.

Table 1-2: LCSS for the Bell Road level crossing

	LCSS	LCSS Risk Band	Criterion Met	Form of Control
Updated Existing (2026)	40/60 – 49/60	MEDIUM-HIGH	-	FLs
Change in Use (2035)	46/60 – 55/60	MEDIUM-HIGH to HIGH	None	FLs
Do Min (2035)	25/60 – 34/60	MEDIUM-LOW to MEDIUM	C1 & C2	HABs, FLBs & coordinated signals
CS (2035)	28/60 – 37/60	MEDIUM-LOW to MEDIUM	C1 & C2	HABs, FLBs & coordinated signals
ST1 (2035)	27/60 – 36/60	MEDIUM-LOW to MEDIUM	C1 & C2	HABs, FLBs & coordinated signals
Do Min (2048)	25/60 – 34/60	MEDIUM-LOW to MEDIUM	C1 & C2	HABs, FLBs & coordinated signals
CS (2048)	29/60 – 38/60	MEDIUM-LOW to MEDIUM	C1 & C2	HABs, FLBs & coordinated signals
ST1 (2048)	29/60 – 38/60	MEDIUM-LOW to MEDIUM	C1 & C2	HABs, FLBs & coordinated signals
Option 10A (2048)	29/60 – 38/60	MEDIUM-LOW to MEDIUM	C1 & C2	HABs, FLBs & coordinated signals
CSS1 (2048)	29/60 – 38/60	MEDIUM-LOW to MEDIUM	C1 & C2	HABs, FLBs & coordinated signals
CSS2 (2048)	29/60 – 38/60	MEDIUM-LOW to MEDIUM	C1 & C2	HABs, FLBs & coordinated signals
Do Min (2063)	26 / 60 – 35/60	MEDIUM-LOW to MEDIUM	C1 & C2	HABs, FLBs & coordinated signals
CS (2063)	30/60 – 39/60	MEDIUM	C2	HABs, FLBs & coordinated signals

	LCSS	LCSS Risk Band	Criterion Met	Form of Control
ST1 (2063)	30/60 – 39/60	MEDIUM	C2	HABs, FLBs & coordinated signals
CSS1 (2063)	30/60 – 39/60	MEDIUM	C2	HABs, FLBs & coordinated signals
CSS2 (2063)	30/60 – 39/60	MEDIUM	C2	HABs, FLBs & coordinated signals

We note that the reduction in risk is primarily through the addition of HABs and coordinating the rail signals with the signals of the proposed intersection layout of Bell Road and Te Puke Highway.

There were eight recommendations made by the LCSIA assessor for the Bell Road level crossing, to reduce risk and to attempt to achieve Criteria 1 and 2. The recommendations are noted in Table 1-3.

Table 1-3: LCSIA assessor recommendations for the Bell Road level crossing

No.	Recommendation	Category
1.	Half arm barrier (HAB) and FLBs installed on both approaches to the Bell Road level crossing to reduce the likelihood of vehicles entering or remaining on the level crossing during train movements.	C1 & C2
2.	Re-orientation of the existing WX1R sign on the western approach to improve visibility and effectiveness.	Maintenance
3.	Installation of a modified WXL sign on the western approaches to account for the close proximity of the level crossing to the Bell Road / Te Puke Highway intersection.	TCD Pt 9
4.	Installation of a WXB1 sign on the eastern approach to provide appropriate advance warning in the rural 100 km/h environment.	TCD Pt 9
5.	Installation of 'RAIL X' pavement markings on the approaches to reinforce driver awareness of the level crossing and discourage queuing over the rail corridor.	TCD Pt 9
6.	Resurfacing of the level crossing with rubber panels or a concrete slab to improve surface condition, reduce the risk of grounding out, and enhance ride quality for all vehicles, particularly heavy commercial vehicles.	C1 & C2
7.	Install clear zone cross hatching over the level crossing to deter queuing over the level crossing.	TCD Pt 9
8.	Reconfiguration of the Bell Road intersection layout to signalise it, to better manage vehicle movements, reduce queuing within the rail corridor, and improve overall operational safety at the crossing. Coordinated road and rail	Signals Standards & Investigation

No.	Recommendation	Category
	<p>signals. Signal phasing allows opposing phases to run concurrently and no short stacking to occur assuming compliance.</p> <p>As there are significant changes to the road corridor proposed that is not well reflected in ALCAM, it is recommended that a Safe System Assessment (SSA) be completed in accordance with NZTA guidelines on the concept, detailed, and for construction design layouts.</p>	

1.4 BELL ROAD DISCUSSION

The Updated Existing and Change in Use LCSS fall within the MEDIUM-HIGH / HIGH risk bands, with the Proposed Design and Future Score falling within the MEDIUM-LOW / MEDIUM risk bands depending on the Engineers' Score. As the overall scores of the Proposed Design and Future Score are lower than the Updated Existing, both scenarios achieve Criterion 2 while failing to achieve Criterion 1. for the majority of options and Engineers' Score,

A summary of the changes to the ALCAM risk band is presented below in Table 1-4.

Table 1-4: Summary of ALCAM changes at Bell Road level crossing

	ALCAM Risk Band	ALCAM Risk Score Change (%)	Fatal Return Period (years)
Updated Existing (2026)	HIGH	-	847
Change in Use (2035)	HIGH	84%	460
Do Min (2035)	MEDIUM-HIGH	-38%	1360
CS (2035)	MEDIUM-HIGH	-20%	1063
ST1 (2035)	MEDIUM-HIGH	-22%	1079
Do Min (2048)	MEDIUM-HIGH	-39%	1393
CS (2048)	MEDIUM-HIGH	-18%	1035
ST1 (2048)	MEDIUM-HIGH	-28%	1168
Option 10A (2048)	MEDIUM-HIGH	-17%	1020
CSS1 (2048)	MEDIUM-HIGH	-18%	1035
CSS2 (2048)	MEDIUM-HIGH	-19%	1041
Do Min (2063)	MEDIUM-HIGH	-35%	1305
CS (2063)	MEDIUM-HIGH	-10%	942
ST1 (2063)	MEDIUM-HIGH	-11%	947

	ALCAM Risk Band	ALCAM Risk Score Change (%)	Fatal Return Period (years)
CSS1 (2063)	MEDIUM-HIGH	-10%	942
CSS2 (2063)	MEDIUM-HIGH	-10%	942

The Updated Existing ALCAM risk band is HIGH and remains HIGH for the Change in Use, resulting in an 84% increase in ALCAM risk score and a reduced fatal return period. The Proposed Design reduces the ALCAM risk band to MEDIUM-HIGH, with the Future Score remaining within the MEDIUM-HIGH risk band, and the ALCAM risk score decreasing by approximately 38% to 10%. Compared to the existing scenario, the likelihood of a fatal crash decreases under both the Proposed Design and Future Score scenarios.

There were/no Red Flag issues raised at this level crossing for any of the assessment stages.

1.5 RECOMMENDED LEVEL CROSSING IMPROVEMENTS

As this is an existing facility upgrade (refer Section 3.2.2), the upgraded Bell Road level crossing is required to meet Criterion 2, with achievement of Criterion 1 desirable but not mandatory. The Proposed Design achieves Criterion 2, with the assessed scenarios generally falling within the MEDIUM to MEDIUM-LOW risk bands; however, sensitivity testing of the Engineers' Score indicates that Criterion 1 is not consistently achieved under higher Engineers' Score assumptions in future year scenarios.

To improve safety and ensure that risk is not increased, all elements of the Proposed Design are recommended for implementation to improve safety for all users and to reduce the likelihood and consequence of vehicle–train conflicts. As Criterion 1 is not achieved for all future scenarios when considering Engineers' Score sensitivity, it is recommended that the applicant progress to the SFAIRP Review process.

1.6 RECOMMENDED UPDATES IN ALCAM

To assist KiwiRail with improvements to the ALCAM database, the following data should be considered to be updated for the existing level crossing in ALCAM:

- Road volumes updated from 3,371 vpd with 5% HCV to 3500 vpd with 5.4% HCV.
- Road crossing left approach surface condition changed from 'good' to 'poor'.
- Road crossing right approach surface condition changed from 'good' to 'poor'.
- Condition of traffic control at crossing changed from 'complete and in good order' to 'some wear and tear but the message is understandable'.
- Crossing geometry changes from 'sealed/good condition' to 'sealed by breaking up/unsealed but firm'.

2 Glossary

AADT	Annual Average Daily Traffic
ALCAM	Australian Level Crossings Assessment Model
CAS	Crash Analysis System
DC	District Council
ECMT	East Coast Main Trunk
FLB	Flashing Lights and Bell
HAB	Half-Arm Barrier
HCV	Heavy Commercial Vehicle
km/h	Kilometres per Hour
LCRAG	Level Crossing Risk Assessment Guidance
LCSIA	Level Crossing Safety Impact Assessment
LCSS	Level Crossing Safety Score
LE	Locomotive Engineer
NZTA	NZ Transport Agency Waka Kotahi
ORA	Operating Reporting Architecture
ppd	Pedestrians per Day
RCA	Road Controlling Authority
SFAIRP	So Far as is Reasonably Practicable
SSSS	Site Specific Safety Score
TCD	Traffic Control Devices
tpd	Trains per Day
vpd	Vehicles Per Day

3 Introduction

3.1 LEVEL CROSSING SAFETY IMPACT ASSESSMENT

While there are a few crashes at level crossings compared with the rest of the road network, the consequences are often a serious injury or fatality. Thus, it is important that any level crossings be effectively investigated through a rigorous risk assessment process, the Level Crossing Safety Impact Assessment (LCSIA).

The LCSIA process was developed to assess the level of crash risk of existing and new / upgraded level crossing designs. Using a Level Crossing Safety Score (LCSS), the risk is scored out of 60, which takes into consideration the Australian Level Crossing Assessment Model (ALCAM) risk scores. This is broken down into the following sections:

- ALCAM score (30 points)
- Crash and Incident History score (10 points)
- Site Specific Safety Score (SSSS) (10 points)
- Engineers' Risk score (10 points).

As can be observed, the ALCAM score is responsible for half of the LCSS. ALCAM is a tool used to identify key potential risks at level crossings and to assist in the prioritisation of crossings for upgrades. It is used to help decide the effective level of treatment required for a crossing.

3.2 LCSIA CRITERIA

There are two criteria applicable to level crossings, which differ depending on whether the crossing is a new crossing facility or an upgrade to an existing facility.

- **C1** Criterion 1: the proposed design / upgrade of a crossing to achieve a "Low" or "Medium-Low" level of risk, as determined by the LCSS
- **C2** Criterion 2: the proposed design / upgrade of a level crossing to achieve a LCSS lower than the existing LCSS.

3.2.1 Proposed Facility

Where a new facility is proposed and no existing ALCAM assessment exists, the new crossing must meet Criterion 1. This will ensure that any new infrastructure constructed over / within the railway corridor is safe for all users and the risk of death or serious injury. Where user exposure is high, then it may not be possible to achieve a "Low" risk without grade separation.

3.2.2 Existing Facility Upgrade

If Criterion 1 cannot be met, the upgraded level crossing must achieve Criterion 2, to ensure the upgraded facility does not increase the level of risk for existing and new users. Achieving Criterion 1 is desirable but not mandatory for an upgrade project.

3.3 STRUCTURE OF THE REPORT

The structure of the report follows the structure as outlined in Level Crossing Risk Assessment Guidance (LCRAG) (version 5, 2022) as set out by KiwiRail.

4 Background

4.1 BRIEF PROJECT OUTLINE

Vitruvius Limited has been engaged to undertake a desktop LCSIA for the Bell Road level crossing, adjacent to Te Puke Highway. This engagement is to assist to inform the wider Traffic Impact Assessment around the future Wairakei South Development.

The LCSIA has been commissioned to support the Wairakei South Fast Track consent application, where the proposed development is expected to introduce a change to traffic demands crossing the railway over time. The Traffic Impact Assessment work identified that the scale and staging of the proposed development will pose a road safety risk to the existing crossing and likely trigger the need for an assessment in accordance with KiwiRail's LCrag, and that level crossing safety is likely to be raised during the consent process.

This LCSIA has been undertaken as a desktop assessment, commissioned solely for the purposes of informing the consent application and associated decision-making. KiwiRail and Western Bay of Plenty District Council have not been engaged or involved in the preparation of this assessment at this stage, noting that the proposed development is not expected to commence until 2029 at the earliest.

The purpose of this LCSIA is to evaluate the current and future safety risk at the Bell Road level crossing, identify the extent of any change in risk associated with the proposed development, and inform whether staged mitigation measures may be required to support the proposed traffic demands over time. Engagement with KiwiRail is intended to occur following the granting of consent and prior to detailed design and implementation.

This LCSIA assesses the following scenarios:

- **Do Min:** Do Minimum for Wairakei South For 2048 and 2063: TTSM 2023 DM network and without Pāpāmoa East Interchange (PEI) bypass ramp in East Bound direction and Bell Road Connection to Te Tumu. For model years 2035, 2048, and 2063.
- **Core Scenario (CS):** Core Scenario with staged Wairakei South development, redistribution of Growth Areas and with Te Tumu development. For model years 2035, 2048, and 2063.
- **Sensitivity Test 1 (ST1):** Sensitivity Test with staged Wairakei South development, redistribution of Growth Areas and without Te Tumu development. For model years 2035, 2048, and 2063.
- **Option 10A:** Sensitivity Test1 with full Wairakei South development, redistribution of Growth Areas and without Te Tumu development. For model year 2048.
- **Comprehensive Sensitivity Scenario 1 (CSS1):** Comprehensive Sensitivity Scenario with PEI; bypass ramp in East Bound direction to Te Tumu. For model years 2048, and 2063.
- **Comprehensive Sensitivity Scenario 2 (CSS2):** Comprehensive Sensitivity Scenario with PEI bypass ramp in East Bound direction and Bell Road Connection to Te Tumu. For model years 2048, and 2063.

Table 4-1 outlines the level crossing details, along with the ALCAM identification number.

Table 4-1: Location of level crossing(s) in this LCSIA report

Report	ALCAM Number	Crossing Name	Region
Bell Road Level Crossing Impact Assessment	1558	Bell Road	Tauranga

4.2 KEY ASSUMPTIONS

The following assumptions have been made:

- This LCSIA has been undertaken as a desktop assessment to inform the Wairakei South Fast Track consent application. At this stage, KiwiRail and WBoPDC have not been engaged or involved in the preparation of this assessment.
- Existing traffic volumes at the Bell Road level crossing have been based on information provided for the purposes of the consent application. No independent validation by KiwiRail, the Road Controlling Authority, or other third parties has been undertaken as part of this assessment.
- Future traffic volumes have been adopted from the modelled scenarios provided, including consideration of the Do Minimum (no Wairakei South development) and the Core Scenario (staged Wairakei South development) for the relevant future model years. No additional growth rates or forecasting assumptions have been applied beyond those supplied.
- Future traffic speeds of 80 km/h have been adopted from the Proposed Design.
- The Proposed Design will provide a minimum of 26m from the new limit line on Bell Road to the track.
- Train volumes are assumed to grow by 1% per annum.
- The Change in Use scenario is the Updated Existing ALCAM record with Future forecasted volumed. The key consideration of the LCSIA is to determine the current and future risk at each level crossing for both the existing infrastructure now and in the future and for any upgrades required to meet KiwiRail Risk Criteria
- The assessment considers the change in traffic demand over time resulting from the proposed development, with the key objective being to understand the current and future level crossing safety risk associated with these changes and to identify whether staged mitigation measures may be required.
- No site visits, night-time inspections, or field surveys have been undertaken as part of this assessment. The LCSIA has been completed using available desktop information, including aerial imagery, existing layout information, and data provided for the purposes of the consent application.

4.3 DOCUMENTS PROVIDED

The following documents and information were provided with regards to the LCSIA:

- Level Crossing Risk Assessment Guidance (LCRAG) 2022 Version 5, NZ Transport Agency Waka Kotahi (NZTA) and KiwiRail
- Signal and Interlocking Plan, 2026, KiwiRail
- Operating Reporting Architecture (ORA) data, 2026, KiwiRail
- Crash Analysis System (CAS) data, 2026, NZTA
- Traffic demand information and future modelled scenarios supplied in Appendix B, including existing traffic demand estimates and future year scenarios associated with the Do Minimum and Core Scenario development cases for the Wairakei South proposal.
- Conceptual layout information and sketches prepared by Boffa Miskell illustrating the proposed Bell Road / Te Puke Highway intersection arrangement and associated traffic management measures to support the proposed development.

4.4 SITE VISITS

No site visit was conducted as part of this desktop LCSIA. Site layout and surrounding area was reviewed using May 2025 Google Street View and based on local knowledge considered representative of the existing layout and condition.

4.5 LCSIA ASSESSOR INDEPENDENCE

The LCSIA assessor has had no prior involvement with the Change in Use project at the level crossing location assessed.

4.6 TOP-DOWN EVALUATION

The first step in the evaluation of a level crossing prior to the LCSIA is a top-down evaluation of options to close or grade separate the level crossing.

If the RCA agrees that the level crossing can be closed, a LCSIA is not required.

The LCSIA report has been commissioned to investigate crossing risks and options as the report is intended to ensure the safety case for continued operation or closure is fully and independently investigated. The RCA will be asked So Far as is Reasonably Practicable (SFAIRP), can the crossing be closed; can an alternative crossing on the same network be closed; or can the crossing be grade separated.

As WBoPDC could not be contacted, the top-down evaluation has been completed by the LCSIA assessor and should be validated by WBoPDC. The top-down evaluation for Bell Road level crossing was as noted in Table 4-2.

Table 4-2: Top-down evaluation of the Bell Road level crossing

1. Can the level crossing be closed? What are the reasons the road controlling authority (RCA) has for pursuing/not pursuing this option?	It is not reasonably practicable to close the crossing as the crossing provides an existing connection between Bell Road and Te Puke Highway and is required to support current and future traffic movements associated with the surrounding road network. The proposed Wairakei South development is expected to increase traffic demands over time, reinforcing the functional role of the crossing rather than reducing it.
2. Can an existing level crossing on the same network be closed? What are the reasons the RCA has for pursuing/not pursuing this option?	It is not reasonably practicable to close another level crossing as the crossing as the nearest level crossings on the same rail network are located more than 4 km to the north and south of the Bell Road level crossing. As such, there are no nearby level crossings that could reasonably be closed to offset or substitute for the continued operation of the Bell Road crossing. Given the distance to the nearest alternative crossings, closure of another level crossing would not provide a practical or effective mitigation for the safety risks associated with the Bell Road level crossing, nor would it maintain appropriate connectivity for the local and strategic road network. Accordingly, closure of an alternative

	level crossing is not considered a reasonably practicable option as part of this assessment.
3. Can the level crossing be grade separated? What are the reasons the RCA has for pursuing /not pursuing this option?	It is not reasonably practicable to grade separate the crossing as grade separation would represent a significant infrastructure intervention requiring detailed investigation, design development, land requirements, and engagement with KiwiRail and the WBoPDC. Such matters fall outside the scope and intent of this desktop assessment, which is focused on understanding safety risk changes over time and identifying whether staged mitigation measures may be required to support the proposed development.

It was not considered reasonably practicable to close or grade separate the level crossing; therefore, the LCSIA was completed.

5 Bell Road LCSIA

5.1 EXISTING CONDITIONS AT THE LEVEL CROSSING

Table 5-1 below provides a summary of the key attributes relating to the level crossing.

Table 5-1: Existing conditions at the Bell Road level crossing

Crossing Name	Bell Road
ALCAM Reference	1558
Type	Road
Crossing Description	Flashing lights
Environment	Rural
Road Geometry	Dip at level crossing to an elevated seagull-style T-intersection with Te Puke Highway, with approximately 25m of separation distance between the rail crossing and the intersection
Posted Speed (km/h)	100
AADT (vpd)	3,500
HCV (%)	5.4
Train Operating Speed (km/h)	70 (retrieved from ALCAM)
Train Volumes (tpd)	12 freight (retrieved from ALCAM)

The Bell Road level crossing is located adjacent to the Bell Road / Te Puke Highway intersection as shown in Figure 5-1. This assessment has been undertaken as a desktop exercise using information provided and a review of available aerial imagery. No site visits or ground-level photographs have been undertaken as part of this LCSIA.

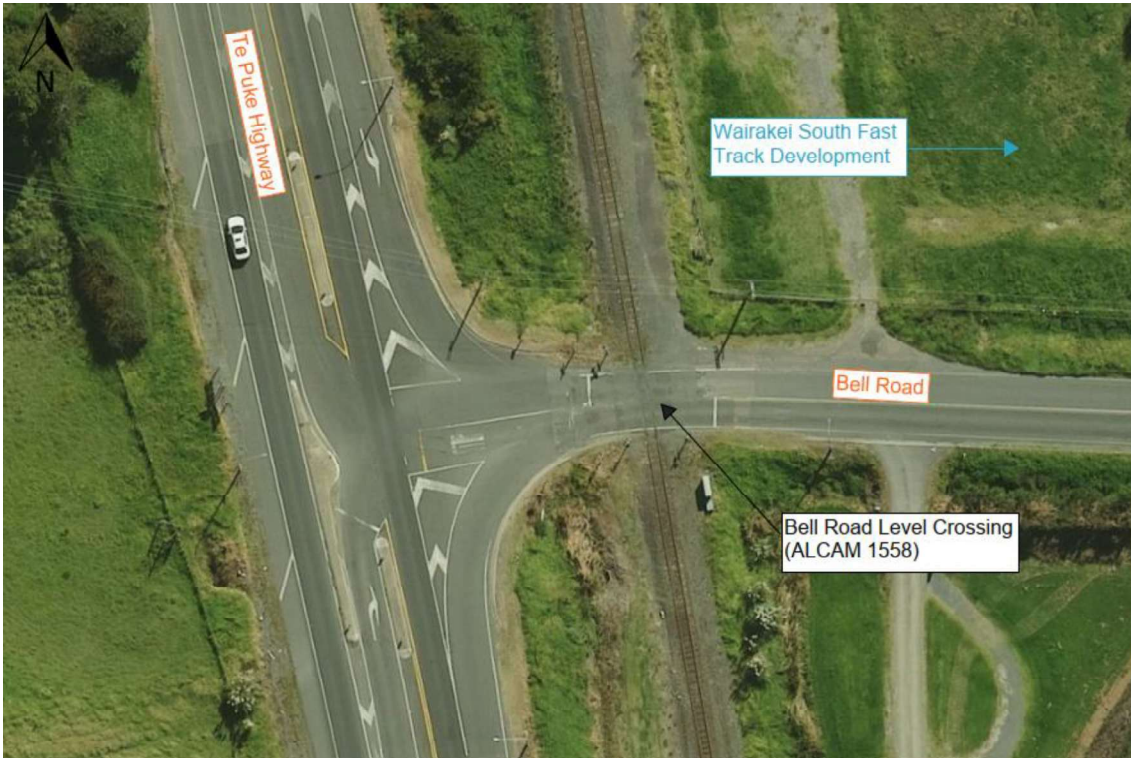

Figure 5-1: Bell Road level crossing (source: Western Bay of Plenty District Council)

The level crossing is in the Tauranga area, located on Bell Road, approximately 3.5km southwest of Papamoa, at a rail chainage of 113.05km on the East Coast Main Trunk (ECMT), as shown in Figure 5-2.

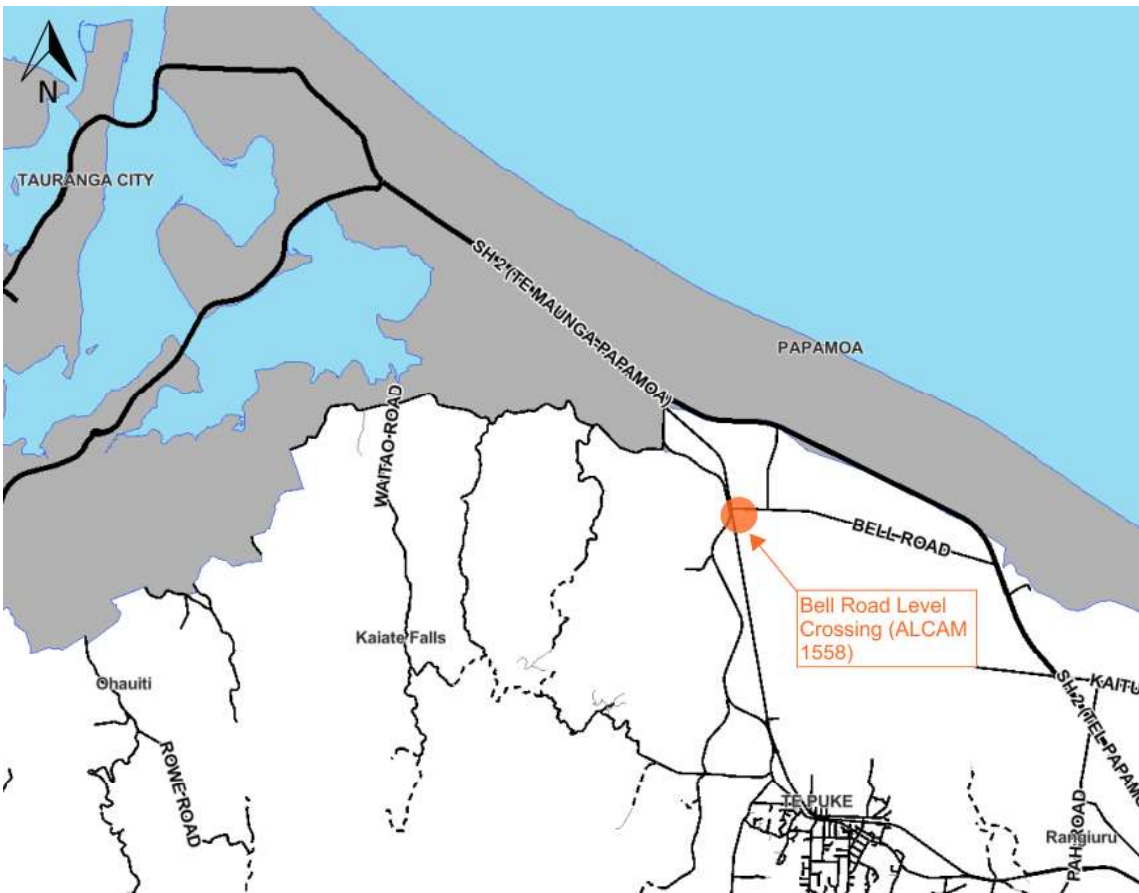

Figure 5-2: Surrounding context of the level crossing (source: Western Bay of Plenty District Council)

The level crossing currently serves traffic travelling between Bell Road and Te Puke Highway and forms part of the existing local and strategic road network. The crossing plays an important functional role in maintaining connectivity, and its location adjacent to the state highway intersection influences vehicle approach speeds, queuing behaviour, and turning movements in the vicinity of the rail corridor.

The proximity of the adjacent Bell Road / Te Puke Highway intersection results in an approximate 25 m separation between the rail track centreline and the nearest road limit line, which constrains vehicle storage between the intersection and the level crossing. This constraint limits the ability for vehicles to queue clear of the rail corridor, particularly during peak traffic conditions or when traffic is influenced by intersection control. These geometric limitations are a key consideration in the assessment of level crossing safety risk.

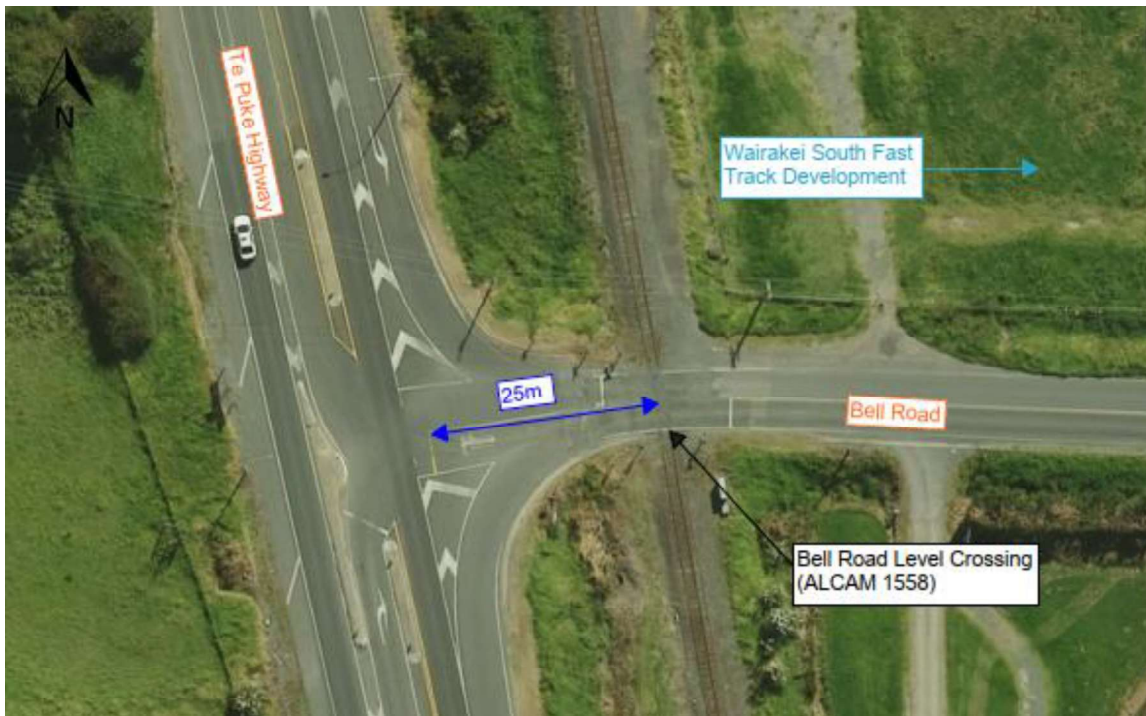

Figure 5-3: Level crossing separation distance to intersection (source: Western Bay of Plenty District Council)

Google Maps Street View was used to assess the level crossing surface and treatments based on the taken May 2025, at the time of the LCSIA.

The level crossing approach surface is in poor condition. There is evidence of cracking and rutting of the chipseal on both approaches to the level crossing as shown below. There is also mild gouging evidenced by grounding out due to the gradient of the level crossing to the Bell Road / Te Puke Highway intersection.



Figure 5-4: Eastern approach surface rutting (source: Google Maps)



Figure 5-5: Western approach surface rutting (source: Google Maps)

From the images available on Google Maps, it appears that the surface at the level crossing itself is also in poor condition. Flange gaps are prevalent as shown below. It appears as though minor patch fixing has occurred over this level crossing which has resulted in a bumpy surface finish,



Figure 5-6: Level crossing surface flange gaps (source: Google Maps)

The Bell Road level crossing is equipped with a duplicated set of flashing lights (FLs) on the western approach, and a single set of FLs on the eastern approaches. It should be noted that the LCSIA team could not assess whether the FLs are fitted with bells; however, for the purposes of this assessment, it has been assumed that these are not as referenced by the LXM base.



Figure 5-7: Eastern approach FLB (source: Google Maps)



Figure 5-8: Western approach FLBs (source: Google Maps)

Sightlines of the level crossing appear sufficient due to the straight and flat geometry of the ECMT. There is limited vegetation to interfere with the level crossing sightlines. Sightlines are noted as per the below photos.



Figure 5-9: Eastern approach sightlines to the north (source: Google Maps)



Figure 5-10: Eastern approach sightlines to the south (source: Google Maps)



Figure 5-11: Western approach sightlines to the north (source: Google Maps)



Figure 5-12: Western approach sightlines to the south (source: Google Maps)

The level crossing is notified by advanced WX1L signs on the western and eastern approach and an additional WX1R on the western approach; however, the WX1R sign on the western approach is orientated incorrectly and does not provide appropriate advanced warning to oncoming vehicles.



Figure 5-13: Eastern approach WX1L



Figure 5-14: Western approach WX1L and WX1R

Whilst not pertaining to the level crossing itself, sightlines of the adjacent intersection could not be assessed in this desktop study; however, the approach of Bell Road to Te Puke Highway is straight and flat. It is therefore assumed that adequate sightlines are achieved for a STOP controlled seagull intersection.

5.2 KEY EXISTING SAFETY ISSUES

The key existing safety issues at the crossing are summarised below

- Short stacking risk due to insufficient queue storage length. The level crossing is located approximately 25 m from the Bell Road / Te Puke Highway intersection, which is below the 26 m minimum queue length required under LCrag v5 to avoid short stacking. This creates a risk of vehicles being unable to queue clear of the rail corridor.
- Close proximity to a high-speed, complex intersection. The crossing is immediately adjacent to a seagull-style T-intersection on a 100 km/h rural road, increasing driver workload and the potential for decision-making errors in close proximity to the rail corridor.
- Risk of vehicles queuing across the level crossing. Limited separation between the intersection and the rail track restricts vehicle storage and increases the likelihood of vehicles stopping or queuing over the crossing during periods of congestion or limited traffic gaps.
- Heavy commercial vehicle exposure. A notable proportion of heavy vehicles use Bell Road, increasing short-stacking risk due to longer vehicle lengths and slower acceleration when entering Te Puke Highway traffic.
- Poor road approach and crossing surface condition. The approach pavement and crossing surface are in poor condition, with cracking, rutting, and uneven repairs that may affect vehicle control, braking performance, and driver confidence.
- Potential grounding risk from vertical geometry. The vertical alignment between the crossing and adjacent intersection presents a risk of grounding out for long or low-clearance vehicles, which could result in vehicles becoming immobilised near the rail corridor.
- Inadequate and incorrectly configured advance warning signage. The WX1R sign on the western approach is incorrectly orientated, advanced intersection with railway signs are absent on both approaches. These deficiencies reduce driver awareness and reaction time in a high-speed environment.

5.3 PROPOSED DESIGN

The proposed design is based on the key existing safety issues identified. This resulted in the following proposed upgrades:

- Half arm barrier (HAB) and FLBs installed on both approaches to the Bell Road level crossing to reduce the likelihood of vehicles entering or remaining on the level crossing during train movements.
- Re-orientation of the existing WX1R sign on the western approach to improve visibility and effectiveness.
- Installation of a modified WXL sign on the western approaches to account for the close proximity of the level crossing to the Bell Road / Te Puke Highway intersection.
- Installation of a WXB1 sign on the eastern approach to provide appropriate advance warning in the rural environment.
- Installation of 'RAIL X' pavement markings on the approaches to reinforce driver awareness of the level crossing and discourage queuing over the rail corridor.
- Resurfacing of the level crossing with rubber panels or a concrete slab to improve surface condition, reduce the risk of grounding out, and enhance ride quality for all vehicles, particularly heavy commercial vehicles.
- Install clear zone cross hatching over the level crossing to deter queuing over the level crossing.

- Reconfiguration of the Bell Road intersection layout to a standard signalised intersection with speed reduction on Bell Road and Te Puke Highway to 80 km/h, to better manage vehicle movements, reduce queuing within the rail corridor, and improve overall operational safety at the crossing. Refer to Figure 5-15 below. Possible escape zones and further signage may be investigated during the design stages.
- Coordinated road and rail signals. Signal phasing allows opposing phases to run concurrently and no short stacking to occur assuming compliance. As there are significant changes to the road corridor proposed that is not well reflected in ALCAM, it is recommended that a Safe System Assessment (SSA) be completed in accordance with NZTA guidelines on the concept, detailed, and for construction layout prior to implementation.
- Vitruvius understands that the proposed development has identified the potential for an alternative mitigation arrangement, including a left in left out at the Bell Road / Te Puke Highway intersection. Initial indications suggest this may address the existing short-stacking risk associated with the right turn bay movement; however, it is noted that the current coordinated signal arrangement already mitigates this issue. Should this option be progressed, it should be assessed through an LCSIA, but expect to present similar risk reduction benefits.



Figure 5-15: Proposed design signalised intersection (source: Boffa Miskell)

5.4 ALCAM UPDATES IN LXM

The following are updates required for LXM are based on the Updated Existing proposal:

- Road volumes updated from 3,371 vpd with 5% HCV to 3500 vpd with 5.4% HCV.
- Road crossing left approach surface condition changed from 'good' to 'poor'.
- Road crossing right approach surface condition changed from 'good' to 'poor'.

- Condition of traffic control at crossing changed from 'complete and in good order' to 'some wear and tear but the message is understandable'.
- Crossing geometry changes from 'sealed/good condition' to 'sealed by breaking up/unsealed but firm'.

5.5 TRAFFIC VOLUMES AND SPEED INPUTS

Table 5-2 identifies the volumes and speeds of vehicles and trains traversing over the level crossing. Refer to Appendix B for ADT plots.

Table 5-2: Risk assessment inputs

	AADT (vpd)	HCV (%)	Road Speed (km/h)	Train Volumes (tpd)	Rail Line Speed (km/h)	Comments
Updated Existing (2026)	3,500	5.4	100	12	70	Mobile Roads extraction provided by Appendix B
Change in Use (2035)	10,100	5.4	100	13	70	Highest volume of vehicles expected based on information provided in Appendix B
Do Min (2035)	6,000	5.4	80	13	70	As attached in Appendix B
CS (2035)	10,100	5.4	80	13	70	As attached in Appendix B
ST1 (2035)	9,800	5.4	80	13	70	As attached in Appendix B
Do Min (2048)	5,000	5.4	80	15	70	As attached in Appendix B
CS (2048)	9,400	5.4	80	15	70	As attached in Appendix B
ST1 (2048)	9,200	5.4	80	15	70	As attached in Appendix B
Option 10A (2048)	9,700	5.4	80	15	70	As attached in Appendix B
CSS1 (2048)	9,400	5.4	80	15	70	As attached in Appendix B
CSS2 (2048)	9,300	5.4	80	15	70	As attached in Appendix B
Do Min (2063)	5,200	5.4	80	17	70	As attached in Appendix B
CS (2063)	10,100	5.4	80	17	70	As attached in Appendix B
ST1 (2063)	10,000	5.4	80	17	70	As attached in Appendix B
CSS1 (2063)	10,100	5.4	80	17	70	As attached in Appendix B
CSS2 (2063)	10,100	5.4	80	17	70	As attached in Appendix B

Note: The typical Future Score timeframe does not exceed 10 years post implementation date. Therefore the 2063 scenarios represent a more conservative assessment.

5.6 ALCAM SCORE

It should be noted that the ALCAM scenarios assessed do not incorporate sighting distance or visibility considerations, as these factors have not been surveyed. Consequently, the proposed change in skew presents an opportunity to improve visibility of approaching locomotives for road users traversing the level crossing.

The ALCAM risk scores and summary for the Bell Road level crossing are shown below in Table 5-3.

Table 5-3: ALCAM risk score

Stage	LCSS Risk Score	Risk Change	Comments
Updated Existing (2026)	25/30	-	This score is based on the existing level crossing. The AADT is currently 3,500 vehicles per day, and train volumes are 12 trains per day. ALCAM risk score is 11.81 (0.001181) and the risk band is HIGH
Change in Use (2035)	28/30	+84%	This score is based on the existing level crossing. The AADT is currently 10,100 vehicles per day, and train volumes are 13 trains per day. ALCAM risk score is 21.76 (0.002176) and the risk band is HIGH
Do Min (2035)	20/30	-38%	This score is based on the proposed design of the level crossing. The AADT is currently 6,000 vehicles per day, and train volumes are 13 trains per day. ALCAM risk score is 7.35 (0.000735) and the risk band is MEDIUM-HIGH
CS (2035)	22/30	-20%	This score is based on the proposed design of the level crossing. The AADT is currently 10,100 vehicles per day, and train volumes are 13 trains per day. ALCAM risk score is 9.41 (0.000941) and the risk band is MEDIUM-HIGH
ST1 (2035)	22/30	-22%	This score is based on the proposed design of the level crossing. The AADT is currently 9,800 vehicles per day, and train volumes are 13 trains per day. ALCAM risk score is 9.27 (0.000927) and the risk band is MEDIUM-HIGH
Do Min (2048)	20/30	-39%	This score is based on the proposed design of the level crossing. The AADT is currently 5,000 vehicles per day, and train volumes are 15 trains per day. ALCAM risk score is 7.18 (0.000718) and the risk band is MEDIUM-HIGH

Stage	LCSS Risk Score	Risk Change	Comments
CS (2048)	23/30	-18%	This score is based on the proposed design of the level crossing. The AADT is currently 9,400 vehicles per day, and train volumes are 15 trains per day. ALCAM risk score is 9.66 (0.000966) and the risk band is MEDIUM-HIGH
ST1 (2048)	23/30	-19%	This score is based on the proposed design of the level crossing. The AADT is currently 9,200 vehicles per day, and train volumes are 15 trains per day. ALCAM risk score is 9.56 (0.000956) and the risk band is MEDIUM-HIGH
Option 10A (2048)	23/30	-17%	This score is based on the proposed design of the level crossing. The AADT is currently 9,700 vehicles per day, and train volumes are 15 trains per day. ALCAM risk score is 9.80 (0.000980) and the risk band is MEDIUM-HIGH
CSS1 (2048)	23/30	-18%	This score is based on the proposed design of the level crossing. The AADT is currently 9,400 vehicles per day, and train volumes are 15 trains per day. ALCAM risk score is 9.66 (0.000966) and the risk band is MEDIUM-HIGH
CSS2 (2048)	23/30	-19%	This score is based on the proposed design of the level crossing. The AADT is currently 9,300 vehicles per day, and train volumes are 15 trains per day. ALCAM risk score is 9.61 (0.000961) and the risk band is MEDIUM-HIGH
Do Min (2063)	21/30	-35%	This score is based on the proposed design of the level crossing. The AADT is currently 5,200 vehicles per day, and train volumes are 17 trains per day. ALCAM risk score is 7.66 (0.000766) and the risk band is MEDIUM-HIGH
CS (2063)	24/30	-10%	This score is based on the proposed design of the level crossing. The AADT is currently 10,100 vehicles per day, and train volumes are 17 trains per day. ALCAM risk score is 10.62 (0.001062) and the risk band is MEDIUM-HIGH
ST1 (2063)	24/30	-11%	This score is based on the proposed design of the level crossing. The AADT is

Stage	LCSS Risk Score	Risk Change	Comments
			currently 10,000 vehicles per day, and train volumes are 17 trains per day. ALCAM risk score is 10.56 (0.001056) and the risk band is MEDIUM-HIGH
CSS1 (2063)	24/30	-10%	This score is based on the proposed design of the level crossing. The AADT is currently 10,100 vehicles per day, and train volumes are 17 trains per day. ALCAM risk score is 10.62 (0.001062) and the risk band is MEDIUM-HIGH
CSS2 (2063)	24/30	-10%	This score is based on the proposed design of the level crossing. The AADT is currently 10,100 vehicles per day, and train volumes are 17 trains per day. ALCAM risk score is 10.62 (0.001062) and the risk band is MEDIUM-HIGH

5.7 CRASH AND INCIDENT HISTORY SCORE

The crash and incident history scores are based on the number of incidents reported in the KiwiRail ORA database and CAS database between 2015 to 2026. For the Bell Road crossing there were five incidents reported in ORA and one in CAS which is a duplicate of an ORA incident.

Table 5-4: 10-year crash data from 2015 – 2026

Database	Incident Number	Incident Date	Incident Type(s)	Description
ORA CAS	EVT2108790 2021204490	28/10/2021	Hit Vehicle	A car struck into the side of the Locomotive of service 381 at Bell Road. Track closed and emergency services required, track staff and maintainer. No Injuries to LE or driver of car.
ORA	EVT2215091	19/07/2022	Near Miss	Level Crossing near miss. Approaching bells road lights on crossing were going. Sounded horn, van sped up and then stopped. Another blast on the horn then the van decided to go and pulled out in front of train.
ORA	EVT2217568	11/08/2022	Near Miss	Near miss with a concrete mixer truck. Truck stopped on crossing. Blew horn, applied brakes. Truck moved off and left the area.
ORA	EVT2335098	26/11/2023	Near Miss	A Dark Grey Subaru Legacy stopped at the crossing and then decided to pull out in front of the approaching train.
ORA	EVT2518764	07/12/2025	Near Miss	Car drove in front of Train at Bell Road level crossing. Car headed towards Te Puke Highway turning right toward Mount Maunganui. Locomotive has dash-cam driving from cab one.

The crash and incident history score is shown in Table 5-5.

Table 5-5: Crash and incident history score

Incident Type	Rating	No. of Incidents	Score
Hit vehicle	4	1	4x1 = 4
Near miss	1	4	1x4 = 4
			8 / 10

The crash and incident history score summed to be 8 for this level crossing.

5.8 SITE SPECIFIC SAFETY SCORE

The SSSS aims to analyse elements of the level crossing layout in that they are either not well covered or missing from the ALCAM risk rating. To achieve a score out of 10, the SSSS is simply prorated down from a score out of 30 and then rounded to the nearest whole number.

If the level crossing triggers a red flag scenario, the SSSS is automatically scored as 24 / 30 (an overall 8 / 10). If the LCSIA assessor is not satisfied the calculated SSSS adequately portrays the risk of the level crossing (if it has over or understated the risk), they are able to provide a 'Modified' SSSS total score.

The SSSS for the Bell Road level crossing is shown in Table 5-6 below.

Table 5-6: SSSS for the Bell Road level crossing

Stage	Crossing Control	Side Road Proximity	Horizontal and Vertical Alignment	Short Stacking and Grounding Out	Road Surface Condition	Total	Red Flag Scenarios	Comments
Updated Existing (2026)	3/5	1/5	1/5	10/10	3/5	18/30	-	Existing LX not fitted with bells; however, scored a 3. Current vehicle volumes are low. The intersection of Bell Road / Te Puke Highway is a seagull formation that a slip lane for left-turn traffic and a dedicated lane for right-turners that could cause infrequent queues. The approach of the existing level crossing results in adequate sightlines of a straight, flat section of track. A score of 4 is given for short stacking due to 5.4% HCVs with inadequate. +6 is awarded for high AADT volumes of 14,000 vpd on Te Puke Highway. +5 is awarded due to evidence of scrape marks on the road surface but there is no known history of grounding out. Existing road condition in average condition. Score of 3 awarded as maintenance is required.
Change in Use (2035)	3/5	3/5	1/5	10/10	5/5	22/30	-	Existing LX not fitted with bells; however, scored a 3. An increase in vehicle volumes could result in queues forming back to the level crossing due to right-turners from Bell Road onto Te Puke Highway. The approach of the existing level crossing results in adequate sightlines of a straight, flat section of track. A score of 4 is given for short stacking due to 5.4% HCVs with inadequate. +6 is awarded for high AADT volumes of 14,000 vpd on Te Puke Highway. +5 is awarded due to evidence of scrape marks on the road surface but there is no known history of grounding out. Increases in traffic volumes will result in further

Stage	Crossing Control	Side Road Proximity	Horizontal and Vertical Alignment	Short Stacking and Grounding Out	Road Surface Condition	Total	Red Flag Scenarios	Comments
Do Min (2035)	2/5	2/5	1/5	0/10	1/5	6/30	-	<p>damage to the pavement. As such, a score of 5 has been awarded.</p> <p>Proposed design to incorporate HABs and FLBs. There is inadequate space to fit a central island to reduce the score to a 1.</p> <p>A slight increase in vehicle volumes could result in occasional queues forming back to the level crossing. Signalising the Bell Road / Te Puke Highway intersection could result in a regraded crossing that maintains perpendicular alignment.</p> <p>A score of 2 is awarded for signals acting as a mitigating factor. With the regrading for the signalisation of the intersection, it is assumed that grounding out will not occur.</p> <p>As the signalisation of the intersection is due to occur between 2029 and 2035, it is assumed the pavement will be in near new condition. Therefore, a score of 1 has been awarded.</p>
CS (2035)	2/5	3/5	1/5	0/10	2/5	8/30	-	<p>Proposed design to incorporate HABs and FLBs. There is inadequate space to fit a central island to reduce the score to a 1.</p> <p>An increase in vehicle volumes could result in queues forming back to the level crossing.</p> <p>Signalising the Bell Road / Te Puke Highway intersection could result in a regraded crossing that maintains perpendicular alignment.</p> <p>As the signalisation of the intersection is due to occur between 2029 and 2035; however, with high traffic volumes, it is assumed the pavement will have minor issues. Therefore, a score of 2 has been awarded.</p>

Stage	Crossing Control	Side Road Proximity	Horizontal and Vertical Alignment	Short Stacking and Grounding Out	Road Surface Condition	Total	Red Flag Scenarios	Comments
ST1 (2035)	2/5	3/5	1/5	0/10	1/5	7/30	-	<p>Proposed design to incorporate HABs and FLBs. There is inadequate space to fit a central island to reduce the score to a 1.</p> <p>An increase in vehicle volumes could result in queues forming back to the level crossing.</p> <p>Signalising the Bell Road / Te Puke Highway intersection could result in a regraded crossing that maintains perpendicular alignment.</p> <p>A score of 2 is awarded for signals acting as a mitigating factor. With the regrading for the signalisation of the intersection, it is assumed that grounding out and short stacking will not occur.</p> <p>As the signalisation of the intersection is due to occur between 2029 and 2035, it is assumed the pavement will be in near new condition. Therefore, a score of 1 has been awarded.</p>
Do Min (2048)	2/5	2/5	1/5	0/10	2/5	7/30	-	<p>Proposed design to incorporate HABs and FLBs. There is inadequate space to fit a central island to reduce the score to a 1.</p> <p>A slight increase in vehicle volumes could result in occasional queues forming back to the level crossing.</p> <p>Signalising the Bell Road / Te Puke Highway intersection could result in a regraded crossing that maintains perpendicular alignment.</p> <p>A score of 2 is awarded for signals acting as a mitigating factor. With the regrading for the signalisation of the intersection, it is assumed that grounding out and short stacking will not occur.</p> <p>As the signalisation of the intersection is due to occur between 2029 and 2035; however, with high traffic</p>

Stage	Crossing Control	Side Road Proximity	Horizontal and Vertical Alignment	Short Stacking and Grounding Out	Road Surface Condition	Total	Red Flag Scenarios	Comments
								volumes, it is assumed the pavement will have minor issues. Therefore, a score of 2 has been awarded.
CS (2048)	2/5	3/5	1/5	0/10	2/5	8/30	-	<p>Proposed design to incorporate HABs and FLBs. There is inadequate space to fit a central island to reduce the score to a 1.</p> <p>An increase in vehicle volumes could result in queues forming back to the level crossing.</p> <p>Signalising the Bell Road / Te Puke Highway intersection could result in a regraded crossing that maintains perpendicular alignment.</p> <p>A score of 2 is awarded for signals acting as a mitigating factor. With the regrading for the signalisation of the intersection, it is assumed that grounding out will not occur.</p> <p>As the signalisation of the intersection is due to occur between 2029 and 2035; however, with high traffic volumes, it is assumed the pavement will have minor issues. Therefore, a score of 2 has been awarded.</p>
ST1 (2048)	2/5	3/5	1/5	0/10	2/5	8/30	-	<p>Proposed design to incorporate HABs and FLBs. There is inadequate space to fit a central island to reduce the score to a 1.</p> <p>An increase in vehicle volumes could result in queues forming back to the level crossing.</p> <p>Signalising the Bell Road / Te Puke Highway intersection could result in a regraded crossing that maintains perpendicular alignment.</p> <p>A score of 2 is awarded for signals acting as a mitigating factor. With the regrading for the signalisation of the intersection, it is assumed that grounding out will not occur.</p>

Stage	Crossing Control	Side Road Proximity	Horizontal and Vertical Alignment	Short Stacking and Grounding Out	Road Surface Condition	Total	Red Flag Scenarios	Comments
Option 10A (2048)	2/5	3/5	1/5	0/10	2/5	8/30	-	<p>As the signalisation of the intersection is due to occur between 2029 and 2035; however, with high traffic volumes, it is assumed the pavement will have minor issues. Therefore, a score of 2 has been awarded.</p> <p>Proposed design to incorporate HABs and FLBs. There is inadequate space to fit a central island to reduce the score to a 1.</p> <p>An increase in vehicle volumes could result in queues forming back to the level crossing.</p> <p>Signalising the Bell Road / Te Puke Highway intersection could result in a regraded crossing that maintains perpendicular alignment.</p> <p>A score of 2 is awarded for signals acting as a mitigating factor. With the regrading for the signalisation of the intersection, it is assumed that grounding out will not occur.</p> <p>As the signalisation of the intersection is due to occur between 2029 and 2035; however, with high traffic volumes, it is assumed the pavement will have minor issues. Therefore, a score of 2 has been awarded.</p>
CSS1 (2048)	2/5	3/5	1/5	0/10	2/5	8/30	-	<p>Proposed design to incorporate HABs and FLBs. There is inadequate space to fit a central island to reduce the score to a 1.</p> <p>An increase in vehicle volumes could result in queues forming back to the level crossing.</p> <p>Signalising the Bell Road / Te Puke Highway intersection could result in a regraded crossing that maintains perpendicular alignment.</p> <p>A score of 2 is awarded for signals acting as a mitigating factor. With the regrading for the</p>

Stage	Crossing Control	Side Road Proximity	Horizontal and Vertical Alignment	Short Stacking and Grounding Out	Road Surface Condition	Total	Red Flag Scenarios	Comments
								signalisation of the intersection, it is assumed that grounding out will not occur. As the signalisation of the intersection is due to occur between 2029 and 2035; however, with high traffic volumes, it is assumed the pavement will have minor issues. Therefore, a score of 2 has been awarded.
CSS2 (2048)	2/5	3/5	1/5	0/10	2/5	8/30	-	Proposed design to incorporate HABs and FLBs. There is inadequate space to fit a central island to reduce the score to a 1. Signalising the Bell Road / Te Puke Highway intersection could result in a regraded crossing that maintains perpendicular alignment. An increase in vehicle volumes could result in queues forming back to the level crossing. A score of 2 is awarded for signals acting as a mitigating factor. With the regrading for the signalisation of the intersection, it is assumed that grounding out will not occur. As the signalisation of the intersection is due to occur between 2029 and 2035; however, with high traffic volumes, it is assumed the pavement will have minor issues. Therefore, a score of 2 has been awarded.
Do Min (2063)	2/5	2/5	1/5	0/10	1/5	6/30	-	Proposed design to incorporate HABs and FLBs. There is inadequate space to fit a central island to reduce the score to a 1. A slight increase in vehicle volumes could result in occasional queues forming back to the level crossing. Signalising the Bell Road / Te Puke Highway intersection could result in a regraded crossing that maintains perpendicular alignment.

Stage	Crossing Control	Side Road Proximity	Horizontal and Vertical Alignment	Short Stacking and Grounding Out	Road Surface Condition	Total	Red Flag Scenarios	Comments
CS (2063)	2/5	3/5	1/5	0/10	2/5	8/30	-	<p>A score of 2 is awarded for signals acting as a mitigating factor. With the regrading for the signalisation of the intersection, it is assumed that grounding out will not occur.</p> <p>As the signalisation of the intersection is due to occur between 2029 and 2035, it is assumed the pavement will be in near new condition. Therefore, a score of 1 has been awarded.</p> <p>Proposed design to incorporate HABs and FLBs. There is inadequate space to fit a central island to reduce the score to a 1.</p> <p>An increase in vehicle volumes could result in queues forming back to the level crossing.</p> <p>Signalising the Bell Road / Te Puke Highway intersection could result in a regraded crossing that maintains perpendicular alignment.</p> <p>As the signalisation of the intersection is due to occur between 2029 and 2035; however, with high traffic volumes, it is assumed the pavement will have minor issues. Therefore, a score of 2 has been awarded.</p>
ST1 (2063)	2/5	3/5	1/5	0/10	2/5	8/30	-	<p>Proposed design to incorporate HABs and FLBs. There is inadequate space to fit a central island to reduce the score to a 1.</p> <p>An increase in vehicle volumes could result in queues forming back to the level crossing.</p> <p>Signalising the Bell Road / Te Puke Highway intersection could result in a regraded crossing that maintains perpendicular alignment.</p> <p>A score of 2 is awarded for signals acting as a mitigating factor. With the regrading for the</p>

Stage	Crossing Control	Side Road Proximity	Horizontal and Vertical Alignment	Short Stacking and Grounding Out	Road Surface Condition	Total	Red Flag Scenarios	Comments
								signalisation of the intersection, it is assumed that grounding out will not occur. As the signalisation of the intersection is due to occur between 2029 and 2035; however, with high traffic volumes, it is assumed the pavement will have minor issues. Therefore, a score of 2 has been awarded.
CSS1 (2063)	2/5	3/5	1/5	0/10	2/5	8/30	-	Proposed design to incorporate HABs and FLBs. There is inadequate space to fit a central island to reduce the score to a 1. An increase in vehicle volumes could result in queues forming back to the level crossing. Signalising the Bell Road / Te Puke Highway intersection could result in a regraded crossing that maintains perpendicular alignment. As the signalisation of the intersection is due to occur between 2029 and 2035; however, with high traffic volumes, it is assumed the pavement will have minor issues. Therefore, a score of 2 has been awarded.
CSS2 (2063)	2/5	3/5	1/5	0/10	2/5	8/30	-	Proposed design to incorporate HABs and FLBs. There is inadequate space to fit a central island to reduce the score to a 1. An increase in vehicle volumes could result in queues forming back to the level crossing. Signalising the Bell Road / Te Puke Highway intersection could result in a regraded crossing that maintains perpendicular alignment. As the signalisation of the intersection is due to occur between 2029 and 2035; however, with high traffic volumes, it is assumed the pavement will have minor issues. Therefore, a score of 2 has been awarded.

5.9 ENGINEERS' SCORE

The engineers' risk score is a combination of the locomotive engineer (LE) and RCA engineers' opinions of the crash risk at the level crossing, with a weighting of 2:1 in favour of the LE. Opinions for this level crossing site were provided by the people mentioned in Section 4.4.

As KiwiRail and Western Bay of Plenty District Council have not been engaged or involved in the preparation of this assessment at this stage, a sensitivity test has been undertaken for the engineers' risk score. Each scenario will be tested against the following scores:

- Low risk – 1/10
- Medium risk – 5/10
- High risk – 10/10

5.10 LEVEL CROSSING SAFETY SCORE

Table 5-7 summarises the resultant LCSS based on the above scores for the Bell Road level crossing.

Table 5-7: LCSS for the Bell Road level crossing

	ALCAM Score	Crash and Incident History Score	Site Specific Safety Score	Engineers' Score	LCSS Score	LCSS Risk Band	Criterion Met	Form of Control	Comments
Updated Existing (2026)	25/30	8 /10	6/10	1/10	40/60	MEDIUM-HIGH	-	FLs	Flashing lights only present.
				5/10	44/60	MEDIUM-HIGH	-		
				10/10	49/60	MEDIUM-HIGH	-		
Change in Use (2035)	28/30	10/10	7/10	1/10	46/60	MEDIUM-HIGH	None	FLs	Assumes an increase in Crash and Incident History Score by two near misses due to increased traffic and train volumes.
				5/10	50/60	HIGH	None		
				10/10	55/60	HIGH	None		
Do Min (2035)	20/30	2/10	2/10	1/10	25/60	MEDIUM-LOW	C1 & C2	HABs, FLBs & coordinated signals	Assumes signalisation and mitigation of short stacking risk. Crash and Incident History Score decreases to two due with HABs and FLBs. C1 is achieved for the 'low' and 'medium' Engineers' Score.
				5/10	29/60	MEDIUM-LOW	C1 & C2		
				10/10	34/60	MEDIUM	C2		

	ALCAM Score	Crash and Incident History Score	Site Specific Safety Score	Engineers' Score	LCSS Score	LCSS Risk Band	Criterion Met	Form of Control	Comments
CS (2035)	22/30	2/10	3/10	1/10	28/60	MEDIUM-LOW	C1 & C2	HABs, FLBs & coordinated signals	Assumes signalisation and mitigation of short stacking risk. Crash and Incident History Score decreases to two due with HABs and FLBs. 2048 traffic volumes are in general, higher than 2035 scenarios; and achieves C2 for all Engineers' Scores. C1 is only achieved for the 'low' Engineers' Score.
				5/10	32/60	MEDIUM	C2		
				10/10	37/60	MEDIUM	C2		
ST1 (2035)	22/30	2/10	2/10	1/10	27/60	MEDIUM-LOW	C1 & C2	HABs, FLBs & coordinated signals	Assumes signalisation and mitigation of short stacking risk. Crash and Incident History Score decreases to two due with HABs and FLBs. C1 is achieved for the 'low' and 'medium' Engineers' Score.
				5/10	31/60	MEDIUM	C2		
				10/10	36/60	MEDIUM	C2		
Do Min (2048)	20/30	2/10	2/10	1/10	25/60	MEDIUM-LOW	C1 & C2	HABs, FLBs & coordinated signals	Assumes signalisation and mitigation of short stacking risk. Crash and Incident History Score decreases to two due with HABs and FLBs. C1 is achieved for the 'low' and 'medium' Engineers' Score.
				5/10	29/60	MEDIUM-LOW	C1 & C2		
				10/10	34/60	MEDIUM	C2		
CS (2048)	23/30	2/10	3/10	1/10	29/60	MEDIUM	C2	HABs, FLBs & coordinated signals	Assumes signalisation and mitigation of short stacking risk. Crash and Incident History Score decreases to two due with HABs and FLBs.
				5/10	33/60	MEDIUM	C2		

	ALCAM Score	Crash and Incident History Score	Site Specific Safety Score	Engineers' Score	LCSS Score	LCSS Risk Band	Criterion Met	Form of Control	Comments
ST1 (2048)	23/30	2/10	3/10	10/10	38/60	MEDIUM	C2		Only C2 is achieved due for all sensitivity tests.
				1/10	29/60	MEDIUM-LOW	C1 & C2	HABs, FLBs & coordinated signals	
				5/10	33/60	MEDIUM	C2		
Option 10A (2048)	23/30	2/10	3/10	10/10	38/60	MEDIUM	C2		Assumes signalisation and mitigation of short stacking risk. Crash and Incident History Score decreases to two due with HABs and FLBs. 2048 traffic volumes are in general, higher than 2035 scenarios; and achieves C2 for all Engineers' Scores. C1 is only achieved for the 'low' Engineers' Score.
				1/10	29/60	MEDIUM-LOW	C1 & C2	HABs, FLBs & coordinated signals	
				5/10	33/60	MEDIUM	C2		
CSS1 (2048)	23/30	2/10	3/10	10/10	38/60	MEDIUM	C2		
				1/10	29/60	MEDIUM-LOW	C1 & C2	HABs, FLBs & coordinated signals	
				5/10	33/60	MEDIUM	C2		
CSS2 (2048)	23/30	2/10	3/10	1/10	29/60	MEDIUM-LOW	C1 & C2	HABs, FLBs & coordinated signals	
				5/10	33/60	MEDIUM	C2		
				10/10	38/60	MEDIUM	C2		

	ALCAM Score	Crash and Incident History Score	Site Specific Safety Score	Engineers' Score	LCSS Score	LCSS Risk Band	Criterion Met	Form of Control	Comments
Do Min (2063)	21/30	2/10	2/10	10/10	38/60	MEDIUM	C2		
				1/10	26/60	MEDIUM-LOW	C1 & C2	HABs, FLBs & coordinated signals	
				5/10	30/60	MEDIUM	C2		
				10/10	35/60	MEDIUM	C2		
CS (2063)	24/30	2/10	3/10	1/10	30/60	MEDIUM	C2	HABs, FLBs & coordinated signals	Assumes signalisation and mitigation of short stacking risk. Crash and Incident History Score decreases to two due with HABs and FLBs. Only C2 is achieved due for all sensitivity tests.
				5/10	34/60	MEDIUM	C2		
				10/10	39/60	MEDIUM	C2		
ST1 (2063)	24/30	2/10	3/10	1/10	30/60	MEDIUM	C2	HABs, FLBs & coordinated signals	
				5/10	34/60	MEDIUM	C2		
				10/10	39/60	MEDIUM	C2		
CSS1 (2063)	24/30	2/10	3/10	1/10	30/60	MEDIUM	C2		
				10/10	39/60	MEDIUM	C2		

	ALCAM Score	Crash and Incident History Score	Site Specific Safety Score	Engineers' Score	LCSS Score	LCSS Risk Band	Criterion Met	Form of Control	Comments
CSS2 (2063)				5/10	34/60	MEDIUM	C2	HABs, FLBs & coordinated signals	
				10/10	39/60	MEDIUM	C2		
				1/10	30/60	MEDIUM	C2	HABs, FLBs & coordinated signals	
			3/10	5/10	34/60	MEDIUM	C2		
		24/30	2/10	10/10	39/60	MEDIUM	C2		

5.11 RECOMMENDATIONS

A summary of the recommendations is shown below in Table 5-8.

Table 5-8: Bell Road level crossing key recommendation

No.	Recommendation	Category
1.	Half arm barrier (HAB) and FLBs installed on both approaches to the Bell Road level crossing to reduce the likelihood of vehicles entering or remaining on the level crossing during train movements.	C1 & C2
2.	Re-orientation of the existing WX1R sign on the western approach to improve visibility and effectiveness.	Maintenance
3.	Installation of a modified WXL sign on the western approaches to account for the close proximity of the level crossing to the Bell Road / Te Puke Highway intersection.	TCD Pt 9
4.	Installation of a WXB1 sign on the eastern approach to provide appropriate advance warning in the rural 100 km/h environment.	TCD Pt 9
5.	Installation of 'RAIL X' pavement markings on the approaches to reinforce driver awareness of the level crossing and discourage queuing over the rail corridor.	TCD Pt 9
6.	Resurfacing of the level crossing with rubber panels or a concrete slab to improve surface condition, reduce the risk of grounding out, and enhance ride quality for all vehicles, particularly heavy commercial vehicles.	C1 & C2
7.	Install clear zone cross hatching over the level crossing to deter queuing over the level crossing.	TCD Pt 9
8.	Reconfiguration of the Bell Road intersection layout to signalise it, to better manage vehicle movements, reduce queuing within the rail corridor, and improve overall operational safety at the crossing. Coordinated road and rail signals. Signal phasing allows opposing phases to run concurrently and no short stacking to occur assuming compliance. As there are significant changes to the road corridor proposed that is not well reflected in ALCAM, it is recommended that a Safe System Assessment (SSA) be completed in accordance with NZTA guidelines on the concept, detailed, and for construction design layouts.	Signals Standards & Investigation

5.12 DISCUSSION

This assessment has been prepared for information purposes only and is not considered a formal LCSIA. The analysis and scores presented are based on desktop assessment and preliminary assumptions. Further collaboration with KiwiRail's locomotive engineer and the WBoPDC's transport engineer is required to confirm operational considerations, validate assumptions, and finalise ALCAM and LCSS inputs prior to any formal LCSIA submission or progression through the SFAIRP process.

The Bell Road level crossing currently operates with FLs only and is located approximately 25 m from the Bell Road / Te Puke Highway intersection in a 100 km/h rural environment. This separation distance is below the 26 m minimum queue length specified in LCRAAG v5 to avoid short stacking, creating a risk of vehicles being unable to queue clear of the rail corridor. The proximity of the crossing to a high-speed, seagull-style T-intersection further increases driver workload and the potential for decision-making errors in close proximity to the rail corridor.

The limited storage between the intersection and the crossing increases the likelihood of vehicles stopping or queuing across the level crossing, particularly during periods of congestion or limited gaps in Te Puke Highway traffic. This risk is exacerbated by the presence of heavy commercial vehicles, which require longer storage lengths and longer acceleration times when entering the state highway. Poor approach pavement and crossing surface condition, together with adverse vertical geometry, further increase the risk of vehicle grounding or immobilisation on or near the rail corridor.

Advance warning treatments at the crossing are also sub-optimal. The WX1R sign on the western approach is incorrectly orientated, and advanced intersection with railway warning signs are absent on both approaches, reducing driver awareness and reaction time in a high-speed environment.

The Updated Existing (2026) assessment places the crossing within the MEDIUM-HIGH LCSS risk band, with sensitivity testing demonstrating elevated risk across all Engineers' Scores. Under the Change In Use scenario (2035), the LCSS increases further, reaching the HIGH risk band, reflecting forecast growth in road traffic and rail movements and an assumed increase in near-miss events. Under these scenarios, the crossing does not meet C1 or C2.

The Proposed Design directly addresses the identified safety issues. The installation of HABs and FLBs on both approaches, together with signalisation of the Bell Road / Te Puke Highway intersection and coordinated road and rail signals, mitigates the short-stacking condition by preventing vehicles from queuing within the rail corridor, assuming compliance. Improvements to advance warning signage, including a modified WXL on the western approaches and a WXB1 on the eastern approach, along with 'RAIL X' pavement markings and clear zone cross-hatching, improve driver awareness and reinforce the requirement to keep the crossing clear. Possible escape zones and further signage may be investigated during the design stages.

Vitruvius understands that the proposed development has identified the potential for an alternative mitigation arrangement, including a left in left out at the Bell Road / Te Puke Highway intersection. Initial indications suggest this may address the existing short-stacking risk associated with the right turn bay movement; however, it is noted that the current coordinated signal arrangement already mitigates this issue. Should this option be progressed, it should be assessed through an LCSIA.

Resurfacing the level crossing with rubber panels or a concrete slab addresses the poor surface condition and reduces the risk of grounding out, improving safety and operational reliability, particularly for heavy commercial vehicles.

As there are significant changes to the road corridor proposed that is not well reflected in ALCAM, it is recommended that a SSA be completed in accordance with NZTA guidelines on the concept, detailed, and for construction design layouts.

Sensitivity testing of the Engineers' Score indicates that, with the proposed upgrades in place, the risk outcomes are robust across low, medium, and high assumptions. The Do Minimum (2035) scenario achieves an LCSS of MEDIUM-LOW, meeting C1 and C2 for low and medium Engineers' Scores and C2

under higher sensitivity testing. Future Scores assessed for 2048 and 2063, including cumulative and sensitivity tests, consistently achieve C2, with C1 not achieved only under higher Engineers' Score assumptions, reflecting conservative treatment of future traffic growth and behavioural uncertainty.

It should be noted that the typical Future Score timeframe does not exceed 10 years post implementation date. Therefore the 2063 scenarios represent a more conservative assessment.

Overall, the proposed upgrades represent a proportionate and effective response to the existing and future safety risks at the Bell Road level crossing and achieve the required safety performance in accordance with LCRAG v5.

5.13 RECOMMENDED IMPROVEMENTS

As this is an existing facility upgrade (refer Section 3.2.2), the upgraded Bell Road level crossing is required to meet Criterion 2, with achievement of Criterion 1 desirable but not mandatory. The Proposed Design achieves Criterion 2, with the assessed scenarios generally falling within the MEDIUM to MEDIUM-LOW risk bands; however, sensitivity testing of the Engineers' Score indicates that Criterion 1 is not consistently achieved under higher Engineers' Score assumptions in future year scenarios.

To improve safety and ensure that risk is not increased, all elements of the Proposed Design are recommended for implementation to improve safety for all users and to reduce the likelihood and consequence of vehicle–train conflicts. As Criterion 1 is not achieved for all future scenarios when considering Engineers' Score sensitivity, it is recommended that the applicant progress to the SFAIRP Review process.



Signal and Interlocking Plan

S & I Diagrams - North of the North Island EAST COAST MAIN TRUNK LINE

WELLINGTON
17/05/05



TE PUKE

S & I DIAGRAM No. 2842
SHEET No. 1 OF 1
DATE IN SERVICE
BULLETIN No.

SIGNALLING & INTERLOCKING ARRANGEMENTS

THESE ARRANGEMENTS WILL BE BROUGHT INTO USE AT A TIME AND DATE TO BE ADVISED BY SEMI-PERMANENT BULLETIN.
THIS CANCELS SKI No. 2813
THESE TO BE COMPLETED BY THE RECEIPT OF THE S & I DIAGRAM

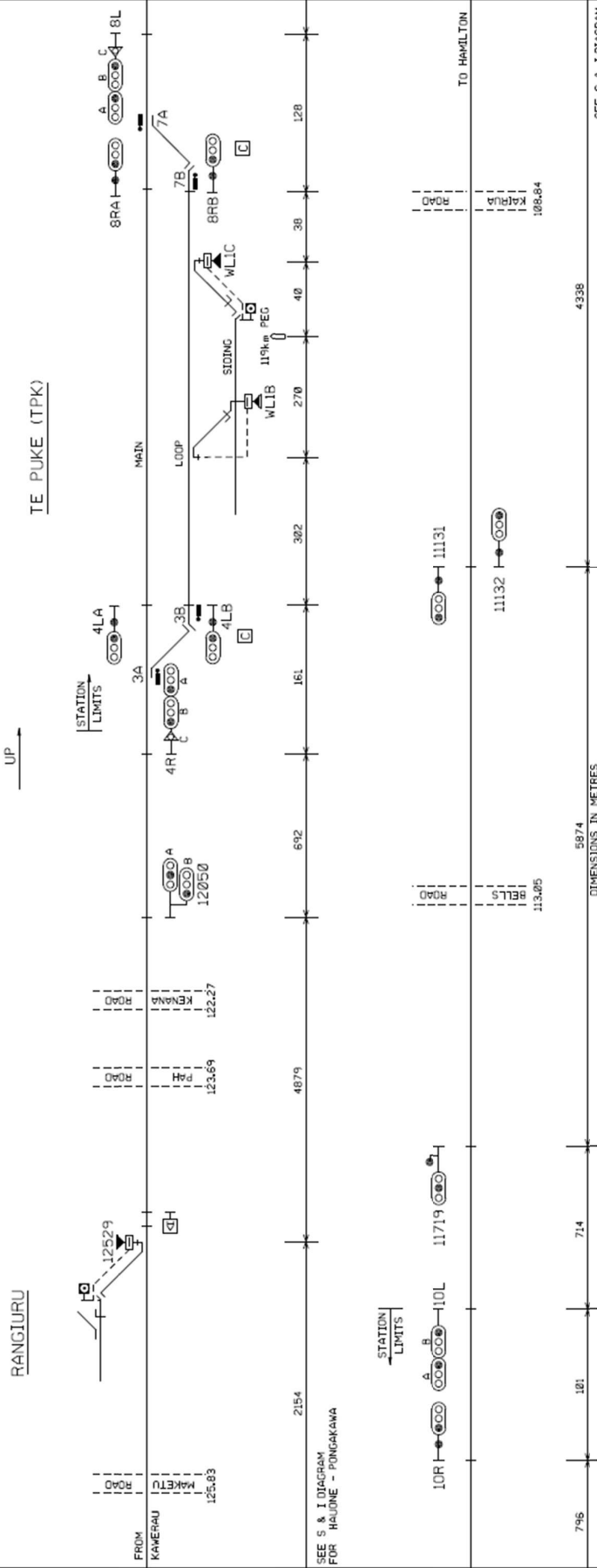

- CONTROLLED NETWORK
— OPERATOR CONTROLLED TERRITORY
- 4RABC UP HOME**
NORMAL SPEED TO MAIN
MEDIUM SPEED TO LOOP
LOW SPEED TO ALL ROADS
- 4LA**
DOWN DEPARTURE FROM MAIN
- 4LB**
DOWN DEPARTURE FROM LOOP
- 8RB**
UP STARTING FROM MAIN
- 8LB**
UP STARTING FROM LOOP
- 8LBC**
DOWN HOME
- 10R**
UP DEPARTURE
- 10LAB**
DOWN OUTER HOME
- DESCRIPTION OF SIGNALS**
NORMAL SPEED TO MAIN
MEDIUM SPEED TO LOOP
LOW SPEED TO ALL ROADS
- 11132**
NORMAL SPEED TO MAIN
MEDIUM SPEED TO LOOP
LOW SPEED TO ALL ROADS

A.E.C. NEILSON
CHIEF SIGNALS & ELECTRICAL ENGINEER

B

Boffa Miskell Limited ADT Plots

Average Daily Traffic (ADT) Vehicles_Y2035_Do Minimum Scenario

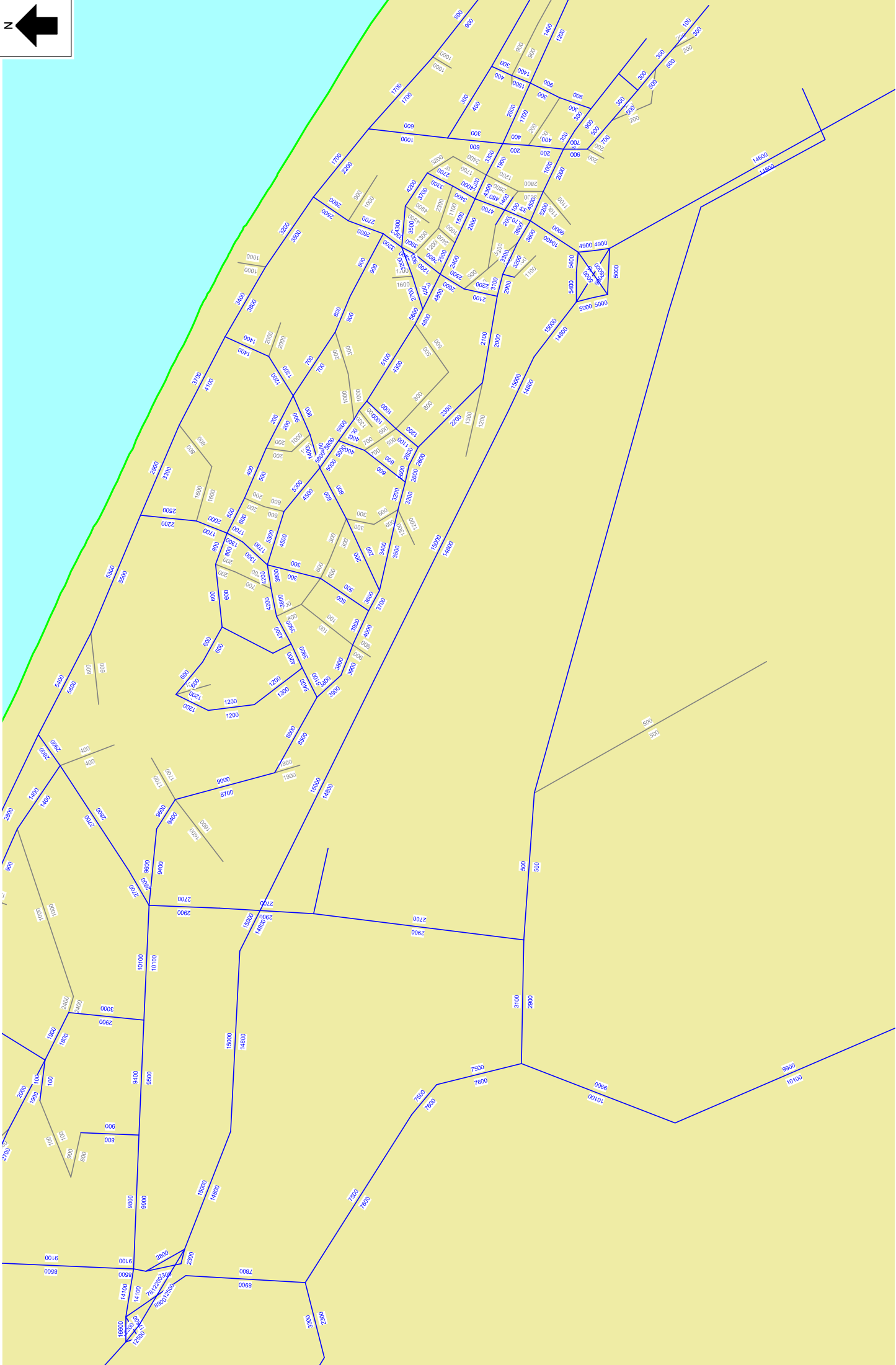

Average Daily Traffic (ADT) Vehicles_Y2035_Core Scenario

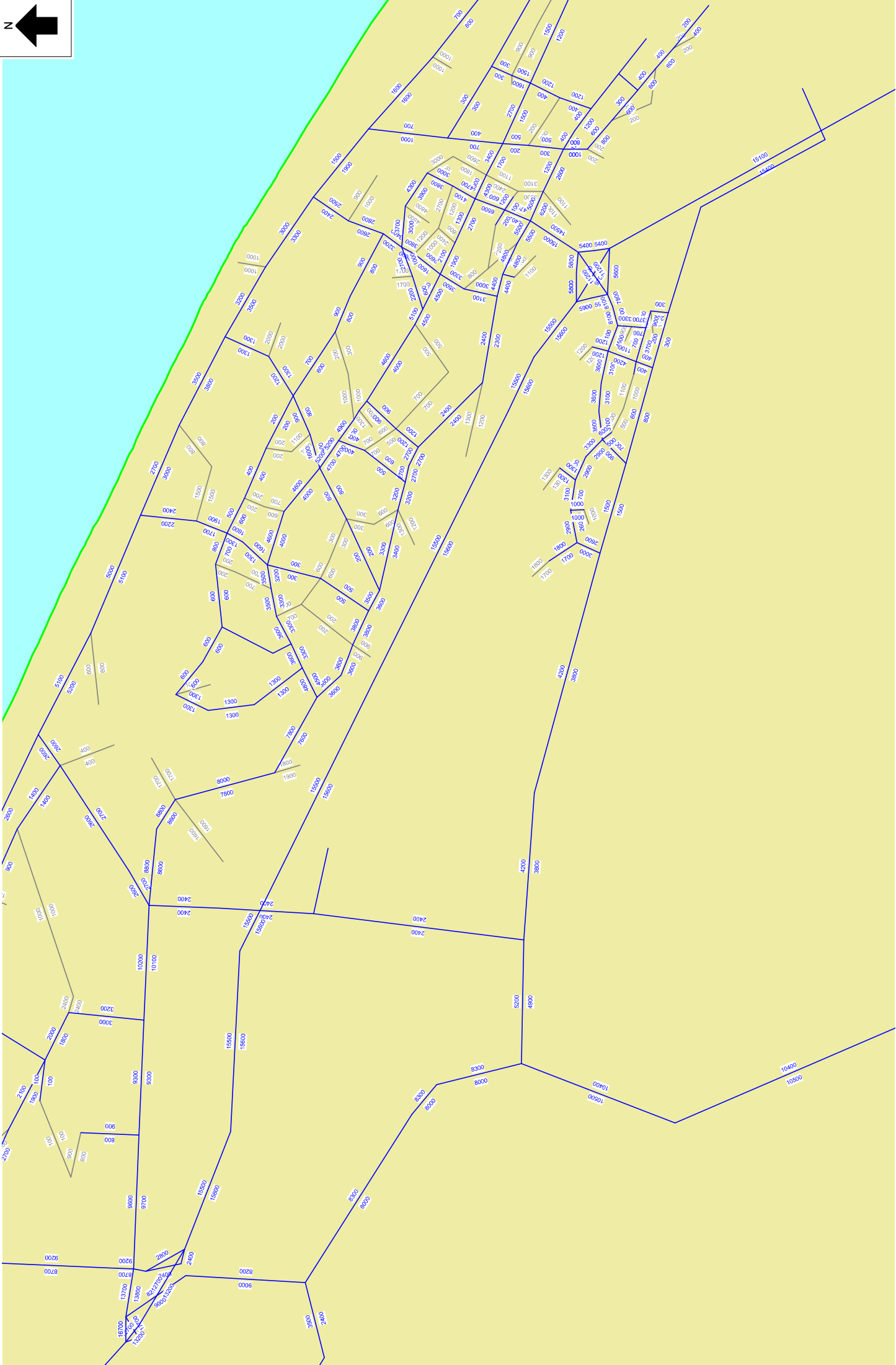

Average Daily Traffic (ADT) Vehicles_Y2035_Sensitivity Test 1 Scenario

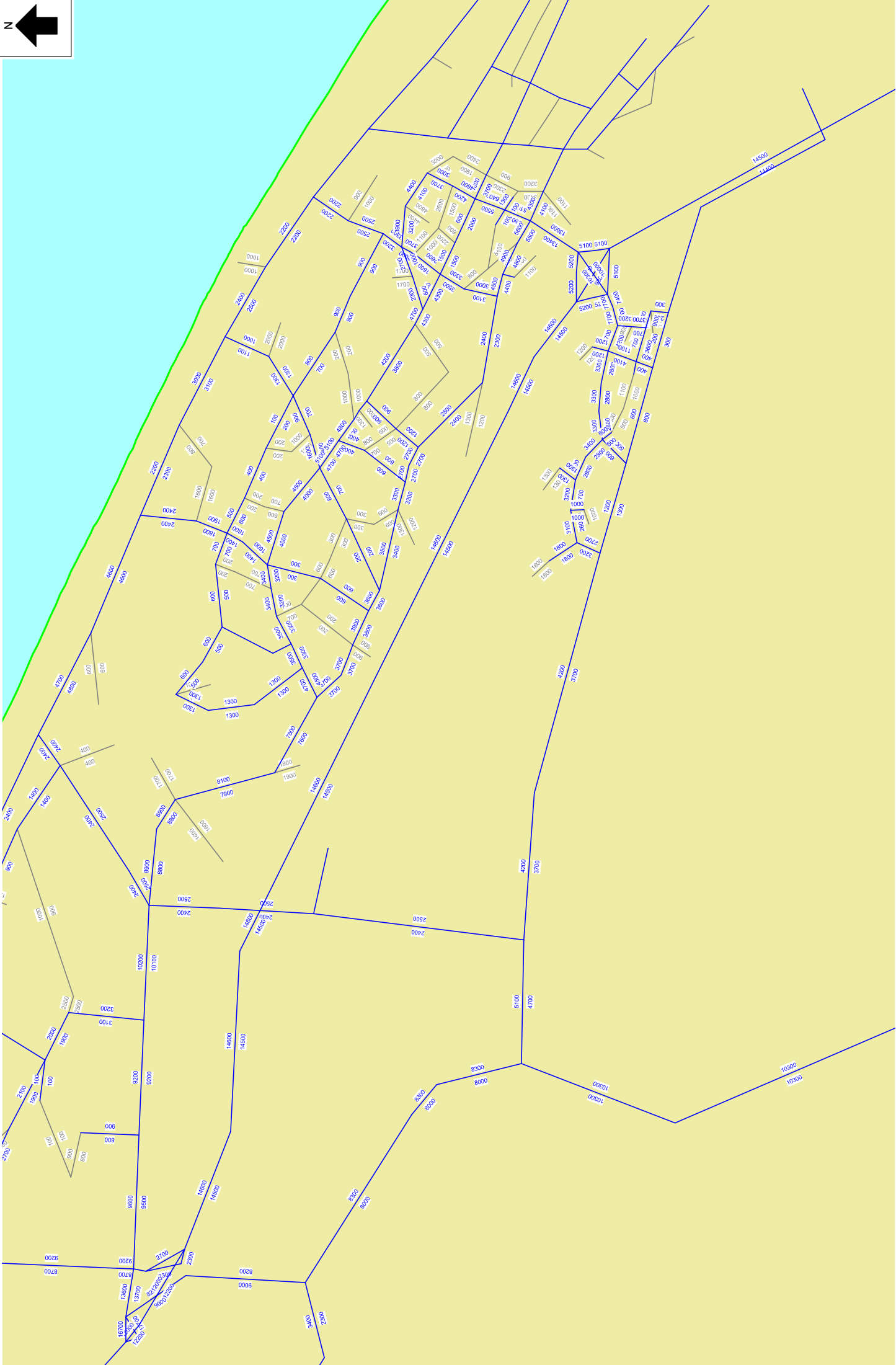

Average Daily Traffic (ADT) Vehicles_Y2048_Do Minimum Scenario

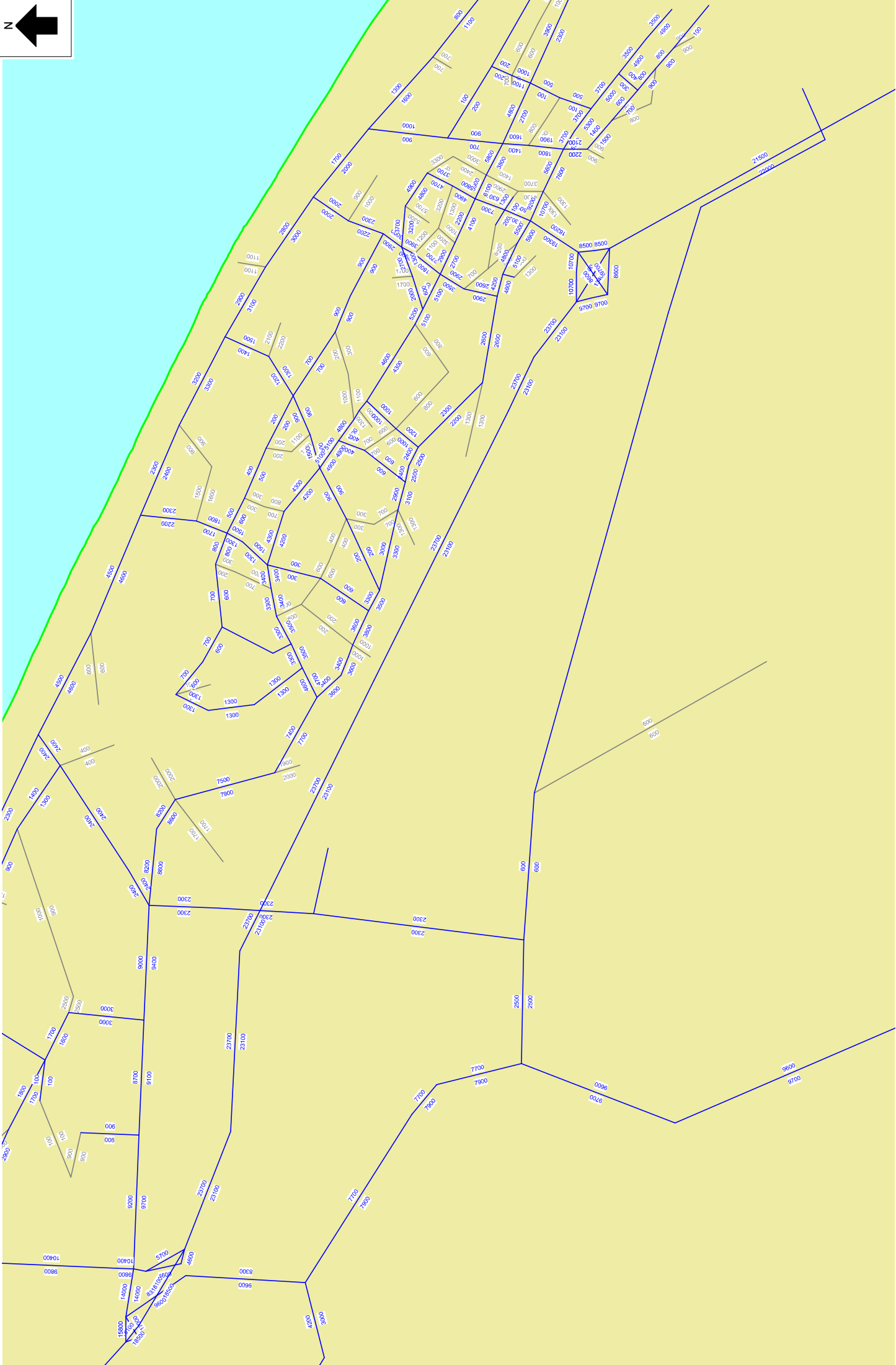

Average Daily Traffic (ADT) Vehicles_Y2048_Core Scenario

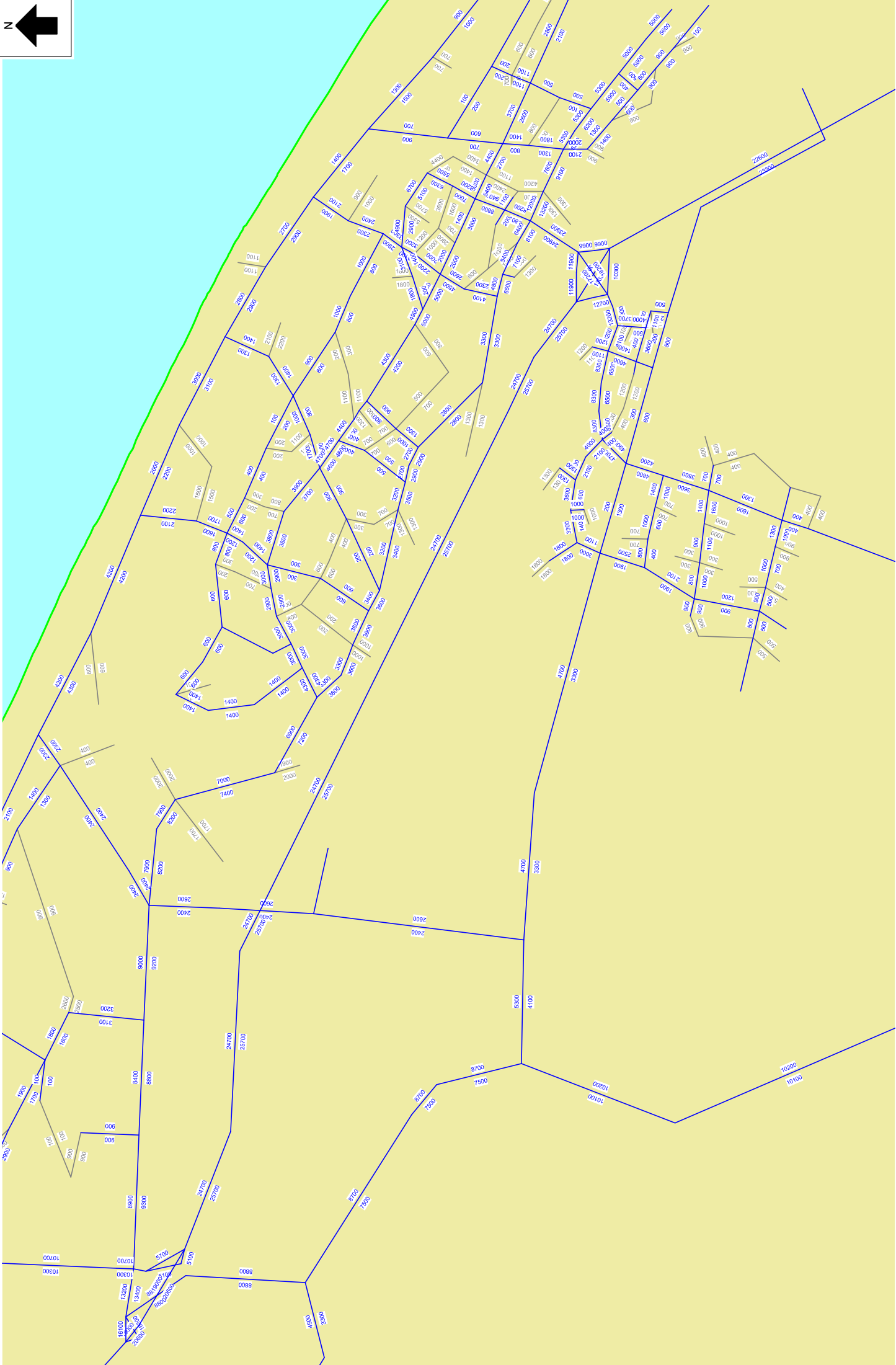

Average Daily Traffic (ADT) Vehicles_Y2048_Sensitivity Test 1 Scenario

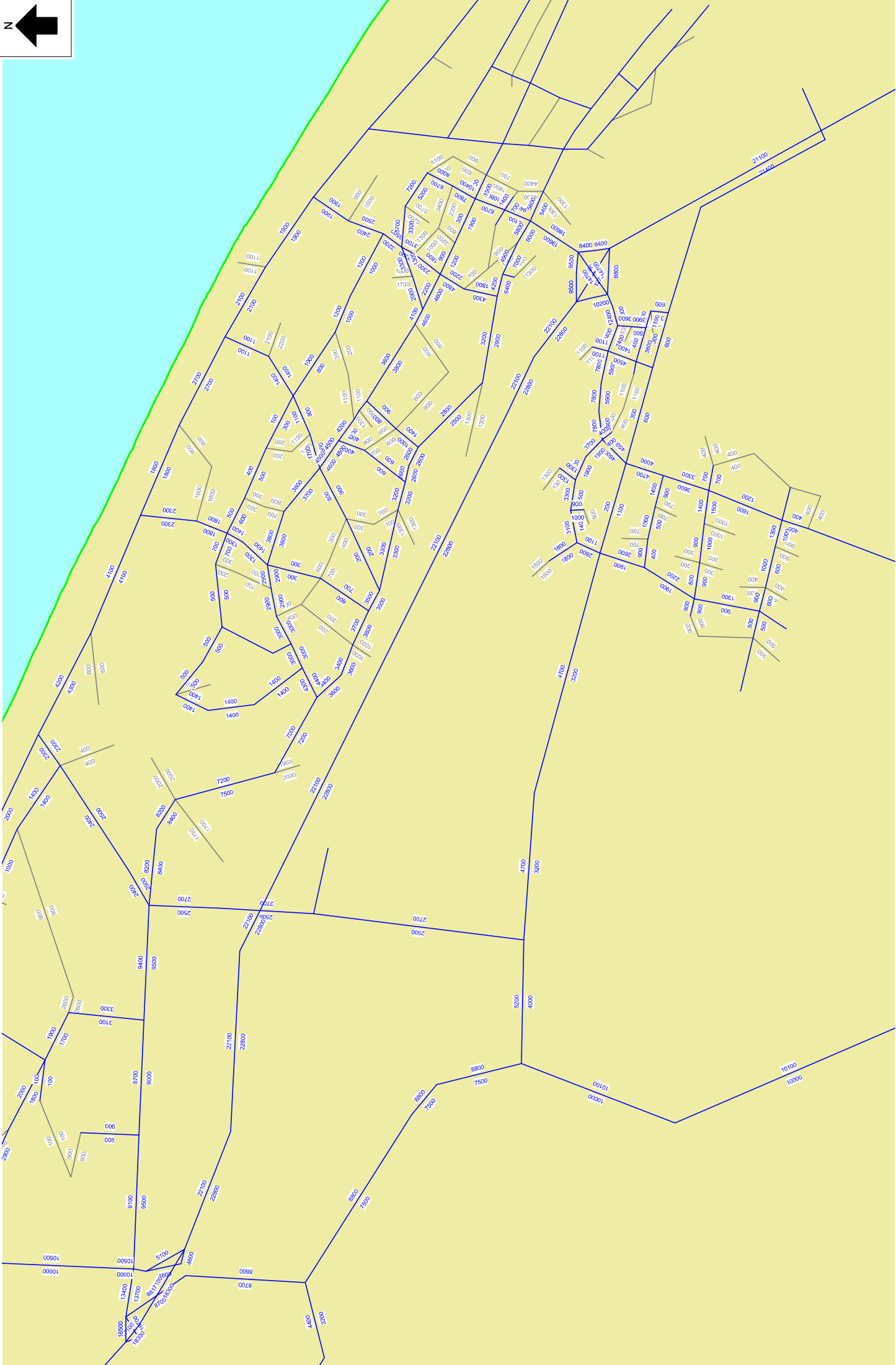

Average Daily Traffic (ADT) Vehicles_Y2048_Option 10A Scenario

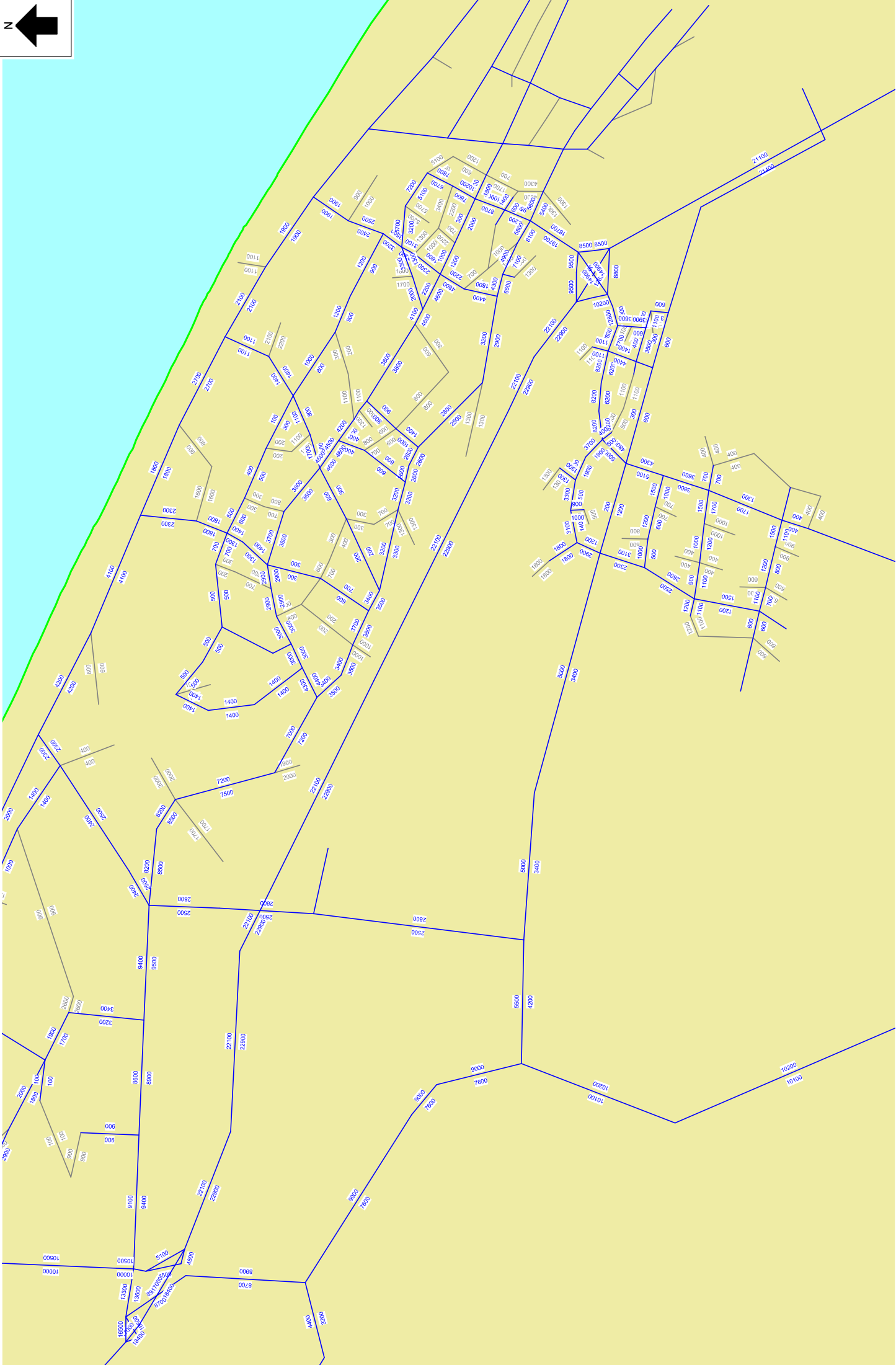

Average Daily Traffic (ADT) Vehicles_Y2048_Comprehensive Sensitivity Scenario 1

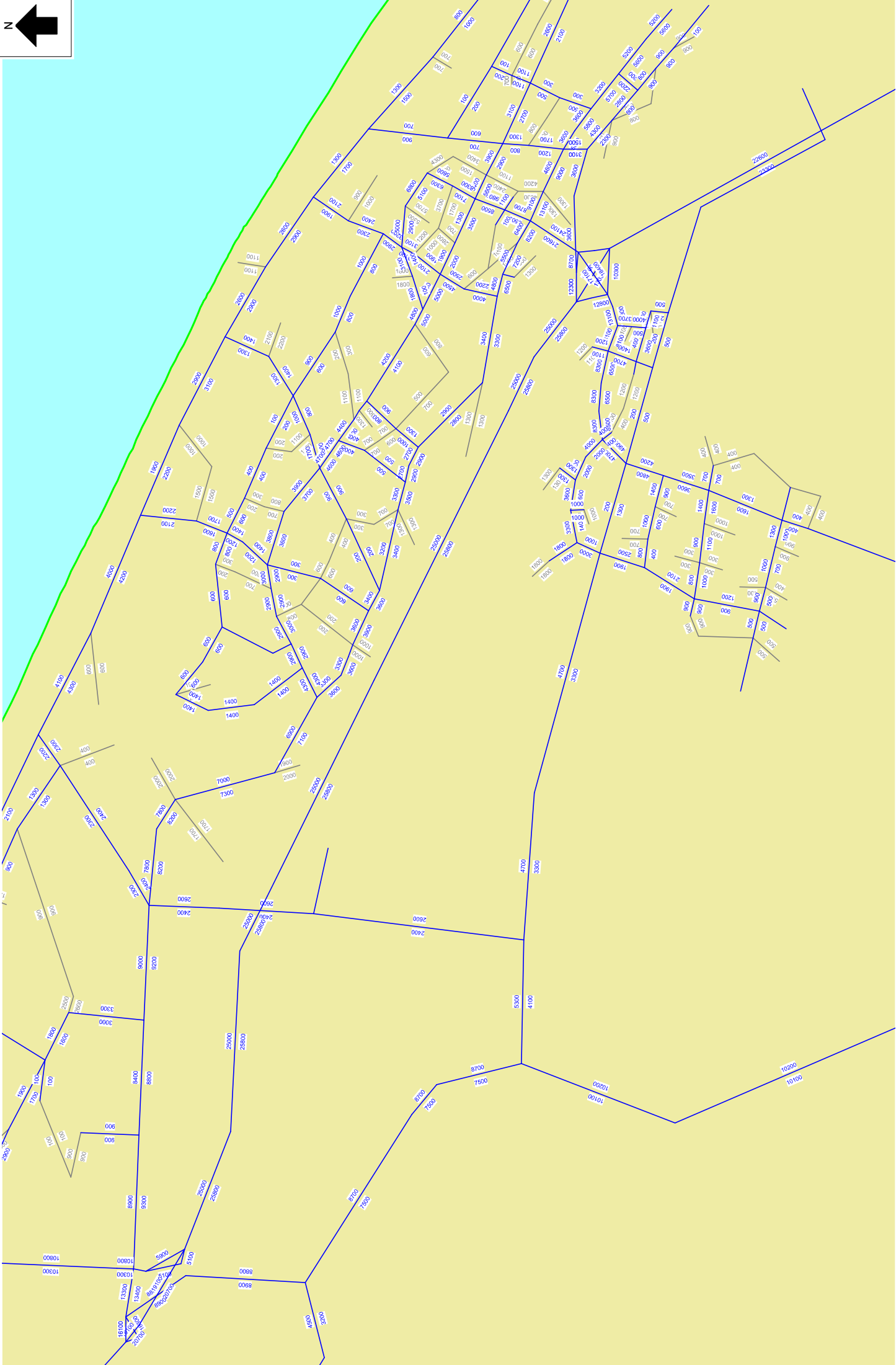
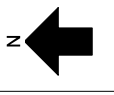

Average Daily Traffic (ADT) Vehicles_Y2048_Comprehensive Sensitivity Scenario 2

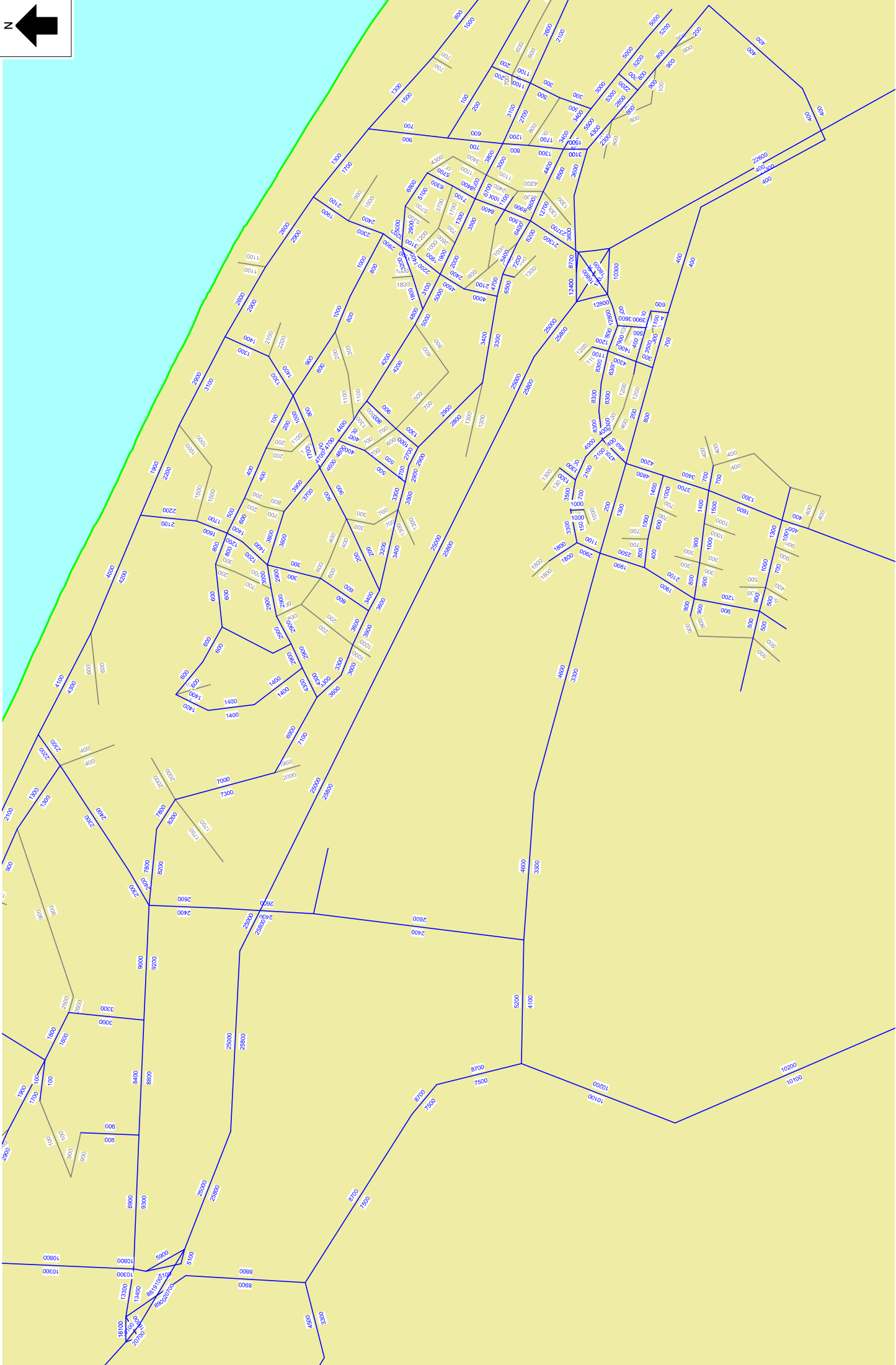
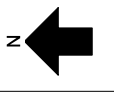

Average Daily Traffic (ADT) Vehicles_Y2063_Do Minimum Scenario

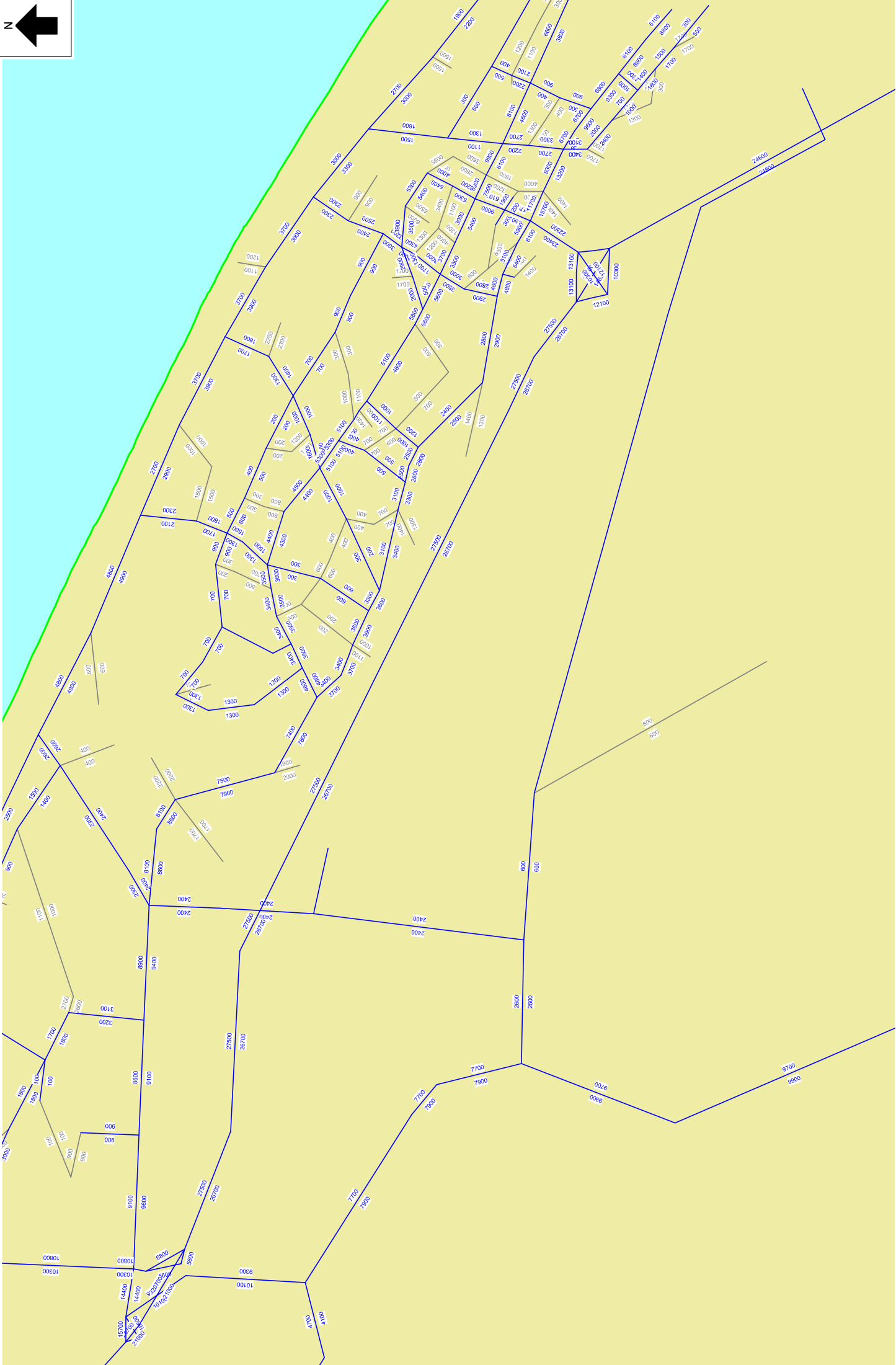

Average Daily Traffic (ADT) Vehicles_Y2063_Sensitivity Test 1 Scenario

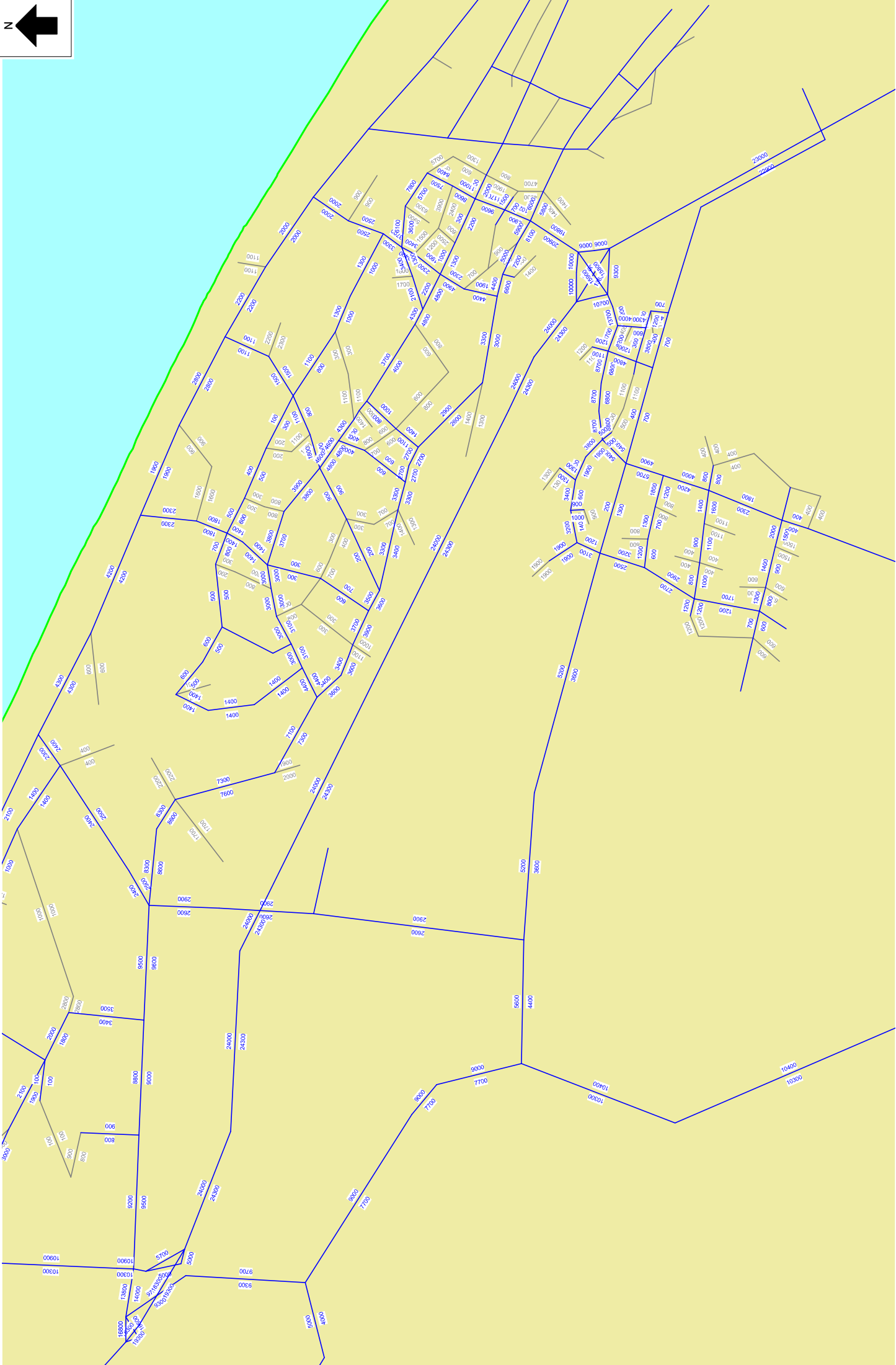

Average Daily Traffic (ADT) Vehicles_Y2063_Comprehensive Sensitivity Scenario 1

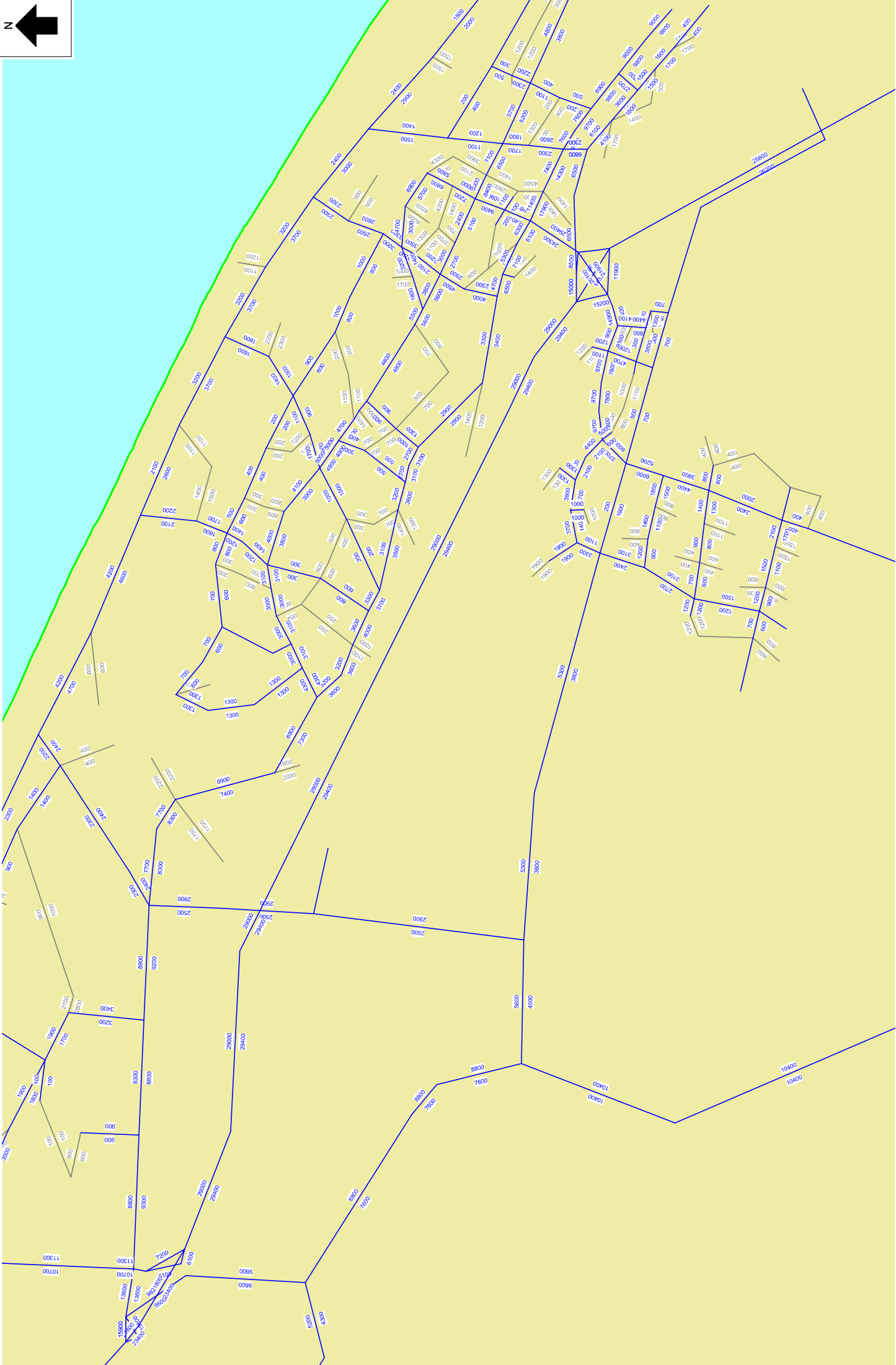

Average Daily Traffic (ADT) Vehicles_Y2063_Comprehensive Sensitivity Scenario 2

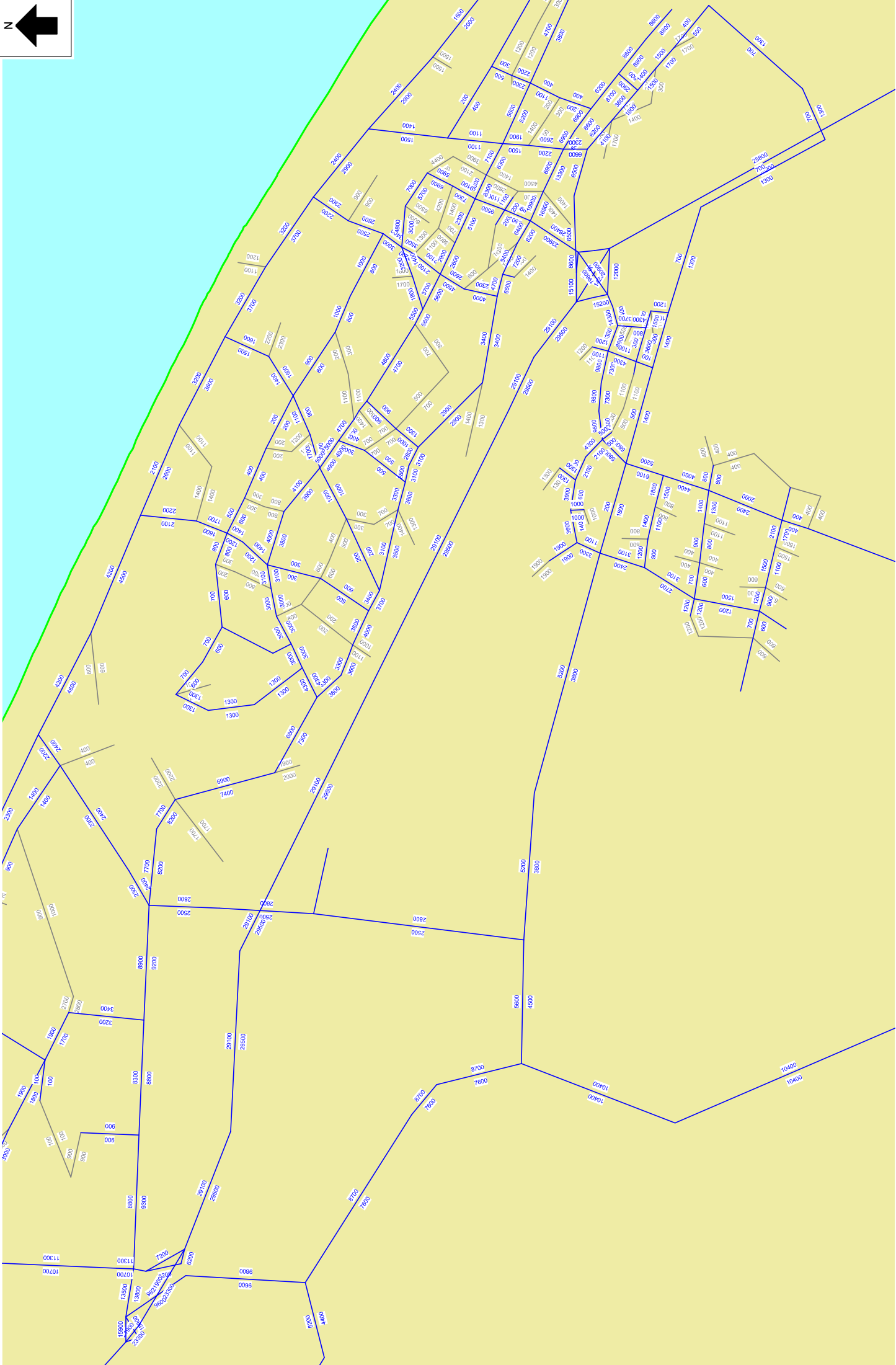

Appendix 13: Bell Road Rural Carriageway Assessment

Current Carriageway Widths Support:

Road Corridor Section	Current Carriageway Section Traffic Volume (two-way total)	Current Carriageway Width (m)	Current Carriageway Supports up to X vpd	Dwellings equivalent 7 trips/hh/day	Industrial ha Equivalent 200 trips/ha/day
Wairakei South western boundary to Panton Road	350	8	1750	250	8.75
Panton Road to Te Puke Highway	3500	8.2	2050		

Road Corridor Section	Carriageway Section Traffic Volume (two-way total) - Up to (vpd)	IDC Carriageway Width (m)	Dwellings equivalent 7 trips/hh/day	Industrial ha Equivalent 200 trips/ha/day
Wairakei South western boundary to Te Puke Highway	100	5.5	14	0.5
	200	5.5	29	1
	500	6.5	71	2.5
	1000	7.5	143	5
	2500	8.5	357	12.5
>2500 - Auoroads		Specific Design		

Auoroads Design Guidelines Part 3: Geometric Design

2.6 Rural Road Widths

Table 4.6: Single carriageway rural road widths (m)

Element	Design AADT			
	1-150	150-500	500-1000	1000-3000
Traffic lanes ⁽¹⁾	3.7 (1 x 3.7)	6.2 (2 x 3.1)	6.2-7.0 (2 x 3.1/3.5)	7.0 (2 x 3.5)
Total shoulder	2.5	1.5	1.5	2.0
Minimum shoulder seal Sub-AADT	0	0.5	0.5	1.0
Total carriageway	8.7	9.2	9.2-10.0	11.0
				12.0

- Traffic lane widths include centralines but are exclusive of edge-lines
- Where significant numbers of cyclists use the roadway, consideration should be given to fully sealing the shoulders. Suggested use of a maximum size 10mm seal within a 20km radius of towns.
- Wider shoulder seals may be appropriate depending on requirements for maintenance costs, soil and climatic conditions or to accommodate the tapered width requirements for Large Combination Vehicles.
- Short lengths of water shoulder seal or fly-bys to be provided at suitable locations to provide for discretionary stops.
- Where appropriate, fly-bys should be provided at suitable locations to provide for discretionary stops.
- A minimum 7.0m seal should be provided on designated heavy vehicle routes (or where the AADT contains more than 15% heavy vehicles).

Transport Model Staged Demands

Road Section	Horizon Year	Dwellings Assumed	Industrial (ha) Assumed	ADT- 2-way Total	Required Carriageway Lane Width (m)	Required Minimum Sealed Shoulder (m)	Required Total Shoulder (m)	Unsealed Shoulder (m)	Comment
Bell Road - Western boundary to Panton Road	2025-2029	-	-	350	7.0	0	2.5	2.5	
	2035	1734	8	8122	7.0	1.5	2.5	1	
	2048	2500	55	7991	7.0	1.5	2.5	1	Reduced demand due to toll removal on TEL
Bell Road O Panton Road to Te Puke Highway	2063	2750	55	8997	7.0	1.5	2.5	1	
	2025-2029	-	-	3500	7.0	1.5	2.5	1	
	2035	1734	8	10072	7.0	1.5	2.5	1	
2048	2500	55	9323	7.0	1.5	2.5	1		Reduced demand due to toll removal on TEL
	2063	2750	55	10092	7.0	1.5	2.5	1	

Table 2: Rural Roads

The table sets out the requirements for carriageway and road reserve widths for all classifications of 'Rural' roads (all Rural 1, 2, 3 and Rural Residential zones in Western Bay of Plenty District Council District).

Maintenance Group Category	Traffic Volume (PCE)	Road Reserve (m)	Carriageway width (m) Excl kerb and channel	Maximum Length	Maximum Gradient, %
7, 8	< 100	20	5	< 20m	12.5
7, 6	< 100	20	5.5	> 20m	12.5
5	100 - 200	20	5.5		12.5
4	201 - 500	20	6.5		12.5
3	501 - 1000	20	7.5		12.5
3	1001 - 2500	20	8.5		12.5
3	> 2500	20	Specific Design		
Cycle Lane within carriageway	Additional carriageway width as shown in Clause 4.2.3				
Resealed Public Road Reserve width sealed with kerb and channel	4-10 lds	10	5.5	50m	20
Private Way, sealed or unsealed, without kerb and channel	1-3 lds	6.0	3.0		
Private Way, sealed or unsealed, without kerb and channel	4-6 lds	12	5.0	Lots up to 1ha sealed surface - 20m; Any other 1ha - 50m	Permanent hard sealed surface - 20%; Any other unsealed surface - 16.7%
Private Way, sealed, with kerb and channel	4-6 lds	8.0	5.0		

Rural roads with a volume count in excess of 2,500 pce shall be designed in accordance with the current State Highway Geometric Design Manual and shall be specifically approved by the Authorised Officer.

Appendix 14: District Plan Assessment

Appendix 14: District Plan Transport Provisions Assessment

Rule	Requirement	Compliance Assessment
Chapter 4B – Transportation, Access and Parking		
4B.4.2	<p>Access to Strategic Roads¹</p> <p>No crossing place shall be permitted to serve any proposed new activity that requires resource consent and/or increases the traffic movements to the site unless:</p> <ol style="list-style-type: none"> i. It is impractical for the activity to have alternative legal access to some other road; and ii. An assessment of the effects of such access on the road including written consent from Waka Kotahi NZ Transport Agency or Council (where relevant) is submitted with the application. The assessment shall address traffic safety, the traffic efficiency of the road, the impracticality of achieving alternative access, the potential for adverse effects on adjacent land owners and adverse effects on the <i>transportation network</i>. <p>Explanatory Note:</p> <p>Where any new crossing is proposed onto a State Highway, approval for that crossing needs to be obtained from Waka Kotahi NZ Transport Agency pursuant to the Government Rooding Powers Act 1989.</p> <p>Waka Kotahi NZ Transport Agency retains control over the design and construction standards of crossing places and road intersections with State Highways.</p> <ol style="list-style-type: none"> b. All properties with legal access to a strategic road shall provide all parking and manoeuvring on site. 	<p>Strategic roads are defined in the District Plan 4B.4.1) as Motorways, Expressways, Primary Arterials (SH2, SH29, SH33 and SH36) and Secondary Arterials (Te Puke Highway, Jellicoe Street, Waahi Beach Road, Athenree/Steele/Emerton Roads, Omokoroa Road (SH2 to Tralee Street), Welcome Bay Road, Te Matai Road, Maketu Road and Tara Road.</p> <p>None of the lots created by the Wairakei South development are proposed to create crossing places on any of these roads.</p> <p>The Wairakei South road network proposes to create a new Secondary Arterial Road which is highlighted blue on the diagram below.</p>  <p>Some employment development lots south of the Bell Road corridor are planned to take access from this new road. A Vehicular Access</p>

¹ The Strategic Road Network includes secondary arterials, primary arterials, expressways and motorways

Rule	Requirement	Compliance Assessment
		<p>Restriction Frontage is shown on the MasterPlan drawing set, Figure 5.11 for all of the Secondary Arterial Corridor north of Bell Road. The road corridor and cross section has been designed to perform a Secondary Arterial function within the future network. No individual residential lots are established with access to it.</p> <p>The road layout and cross-sections have been developed having regard to this function, including the need to accommodate through traffic while also enabling appropriate local access. In this context, a limited number of direct accesses have been anticipated as part of the subdivision design.</p> <p>The effects of these accesses will be appropriately managed through the proposed conditions and the application of relevant District Plan and Development Code requirements. This includes controls on the location and spacing of vehicle crossings, provision for safe sight distances, and requirements for on-site parking and manoeuvring to ensure that vehicles can enter and exit sites safely and without adverse effects on the operation of the road.</p> <p>These provisions appropriately minimise access to the new secondary arterial road and where crossing places are provided, ensure they are appropriately designed and located.</p>
4B.4.3	<p>Access to Rural Roads (Rural, Lifestyle and Future Urban Zones) other than Strategic Roads</p>	<p>N/A</p> <p>This rule applies to vehicle access in Rural, Lifestyle and Future Urban Zones. The Wairakei South development is proposed as an urban subdivision, with access provided via an internal road network connecting to the surrounding urban transport network.</p> <p>No access is proposed to rural roads, and accordingly this rule does not apply.</p>
4B.4.4	<p>Access to Urban Roads (Residential, Medium Density Residential, Rural-Residential, Natural Open Space, Commercial and Industrial Zones) other than Strategic Roads</p> <p>a. Subdividers shall normally be required to provide only those crossings where the location is fixed at the time of subdivision, such as <i>Privateways</i>. In all other cases, the crossings shall be constructed at the time of building.</p>	<p>a. Complies. Some vehicle crossings will be constructed at the time of subdivision where locations are fixed (e.g. privateways or constrained sites), while others will be formed at the time of building. This approach is consistent with the intent of the rule.</p> <p>b. Compliance expected. Lot layout and road design provide adequate opportunity for vehicle crossings to achieve the</p>

Rule	Requirement	Compliance Assessment
4B.4.5	<p>b. Distance from Road Intersections - No vehicular access shall be located nearer than 8m in a Residential, Medium Density Residential, Rural-Residential or Natural Open Space Zone or nearer than 25m in a Commercial or Industrial Zone from the road intersection, measured from the intersection of the legal road boundaries or any part of a road on which the Council has resolved that no vehicle may stop in accordance with the provisions of the Transport Act and any regulations pursuant to that Act.</p> <p>c. The maximum gradient for a private access (vehicle crossing and driveway) serving one lot shall be 1 in 4.5 (22.2%) as per Council's Development Code Standard Drawing W436.</p> <p>Loading Path and Space Dimensions Activities requiring loading facilities or servicing from heavy vehicles shall comply with the 90 percentile design two axled truck swept path and minimum loading space dimensions or a greater dimension of design where articulated vehicles or trucks and trailers are anticipated.</p>	<p>required separation from intersections. Compliance will be confirmed at detailed design and building stage.</p> <p>c. Compliance expected. Vehicle crossing gradients are to be designed in accordance with Development Code requirements at detailed design stage.</p> <p>Compliance expected.</p> <p>The internal road network and intersection layouts have been designed to accommodate appropriate design vehicles, as informed by transport modelling and supporting civil design. This ensures that loading and servicing requirements associated with future activities can be appropriately provided for.</p> <p>Compliance with loading path and space dimension requirements for individual lots will be confirmed at the time of land use and building development, when the nature and scale of activities are known.</p>
4B.4.6	<p>On-site Manoeuvring All activities shall provide manoeuvring space onsite so that all vehicles can enter and exit without reversing on to or off the road. Such manoeuvring shall be able to be executed in no more than a three-point turn. <u>Except that:</u> <i>Dwellings</i> in the Residential and Medium Density Residential Zone with direct access off a District Road are not required to provide for onsite manoeuvring.</p>	<p>Compliance expected.</p> <p>Where on-site manoeuvring is required by the District Plan, the subdivision layout and road design provide appropriate access and space to enable compliance.</p> <p>Detailed manoeuvring requirements for individual lots will be addressed at the time of land use and building development, when the nature and scale of activities are known. The proposed conditions framework ensures that access and internal layouts are designed to accommodate safe vehicle movements without adverse effects on the road network.</p>
4B.4.7	<p>Parking and Loading Requirements</p>	<p>Compliance expected.</p>

Rule	Requirement	Compliance Assessment
4B.4.8	<p style="text-align: center;">Alternative means of Provision of Parking and Loading</p>	<p>Parking provision will be assessed as part of future development, with any requirements to be addressed through detailed design and, where appropriate, the proposed conditions framework. The lot arrangements as proposed are of an adequate size and shape to enable compliance.</p> <p>Compliance expected.</p> <p>No alternative parking or loading arrangements are proposed as part of the subdivision. Compliance with parking and loading requirements will be addressed at the time of land use and building development.</p>
4B.4.9	<p>Location of Parking and Loading areas</p> <p>The provision for parking and loading in respect of any site shall not be on:</p> <ol style="list-style-type: none"> a. Part of any manoeuvring area or access lane, or road. b. Any screening required by the District Plan. c. Any solid waste storage area required by the District Plan. <p><u>Provided that:</u></p> <p>In Commercial and Industrial Zones manoeuvring may be on service lanes where land for service lane is given by the applicant.</p> <ol style="list-style-type: none"> d. Parking spaces shall not occupy loading spaces nor loading spaces occupy parking spaces. e. Parking and loading spaces are to be either visible from the public road or clearly signposted at the road frontage. 	<p>Compliance expected</p> <p>Parking and loading areas on individual lots are to be provided in accordance with District Plan requirements at the time of land use and building development.</p>
4B.4.10	<p>Formation of Parking and Loading areas</p> <p>Parking and loading areas shall be sealed in Residential, Commercial and Industrial zones and metalled as a minimum in Rural-Residential, Future Urban, Rural, Lifestyle and Natural Open Space Zones so as not to create a dust nuisance to adjoining properties, except in respect of the 3m of any carpark immediately adjoining Strategic Roads that shall be paved in all zones.</p>	<p>Compliance expected</p> <p>Parking and loading areas on individual lots are to be formed in accordance with District Plan requirements at the time of land use and building development, with details to be confirmed at detailed design stage.</p>
4B.4.11	<p>Stack Parking</p>	<p>Compliance expected.</p>

Rule	Requirement	Compliance Assessment
	Council shall accept stacked parking only in the case of dwellings provided that the stacking area is exclusive of all those matters listed in 4B.4.9 above.	Stacked parking may be provided where permitted. This will be confirmed at the time of building development on residential lots.
4B.4.12	<p>Service Lanes</p> <p>All new activities shall provide Council with the land for a service lane at the rear or at the side of the site as required in accordance with the Planning Maps.</p> <p>The service lane widths and dimensions required from each site shall be in accordance with dimensions as stated in the relevant designation.</p>	<p>N/A</p> <p>No service lanes are identified or required for the site under the District Plan. The proposed road network provides appropriate access and servicing arrangements for the development, and no service lanes are necessary to support the intended land use.</p>
<p>Chapter 12 – Subdivision and Development</p> <p>12.4.4 Transportation and Property Access</p>		
12.4.4.1	<p>General</p> <p>a. Council will exercise control over:</p> <p>i. The function and design of new roading in relation to the needs of the subdivision, the existing roading pattern and the likely future roading needs of other potentially subdividable land in the vicinity;</p> <p>ii. The upgrading of any existing roading necessary to serve the subdivision;</p> <p>iii. The potential impact of the subdivision on the function of strategic roads as identified within the <i>roading hierarchy</i> and proposed mitigation measures.</p> <p>b. Where a subdivision or <i>development</i> includes the vesting of a new road or has access to a Council road or State Highway it shall be designed to ensure safe and efficient movement of traffic (including heavy vehicles), while providing for pedestrian and cycleways, public transport, landscaping and tree planting.</p>	<p>a.</p> <p>i. The proposed road network has been designed to respond to the needs of the subdivision and integrate with the existing and planned roading pattern, including provision for future development of adjoining land.</p> <p>ii. Upgrading of the surrounding network is identified where required and is addressed through the staged mitigation framework set out in this ITA.</p> <p>iii. The effects on the wider transport network, including strategic routes, have been assessed through transport modelling, with mitigation measures identified where appropriate.</p> <p>b. The proposed road network, including new roads to be vested, has been designed to provide for safe and efficient movement of all users. This includes provision for vehicles (including heavy vehicles), as well as walking, cycling and future public transport, consistent with the intended function of the network. A safety audit provision is included within the WBOPDC Development Code and has been further specified in the proposed conditions framework in the ITA report.</p>

Rule	Requirement	Compliance Assessment
12.4.4.2	<p>Proposed Roads</p> <p>Road reserve and pavement widths shall be as set out below. The measurements are minimums and may need to be widened to accommodate matters such as cycleways and geometry.</p> <p>Table 1: Urban Roads (Residential, Medium Density Residential, Rural-Residential, Commercial and Industrial Zones) (see below)</p>	<p>The proposed road network has been designed in accordance with the District Plan and Development Code and further, specific subdivision cross-section standards are included in the conditions framework.</p>
12.4.4.3	<p>Streetscape Landscaping</p> <p>Where a subdivision proposes to include a road to be vested in Council, any streetscape landscaping to be provided to enhance the amenity of the area shall be designed to ensure continued traffic and pedestrian safety.</p>	<p>This is addressed in other parts of the Application.</p>
12.4.4.4(a)	<p>a. Lots to be served by formed legal roads</p> <p>Land comprising each proposed lot shall be served by a new road constructed by the subdivider in accordance with the foregoing</p> <p>Rules 12.4.4.1.a. and b. and 12.4.4.2 or shall at the time subdivision consent is applied for, be served by a road network comprising legal public roads each of which are formed, metalled or sealed, and currently maintained by Council.</p> <p><u>Provided that:</u></p> <ol style="list-style-type: none"> i. This rule shall not apply in the case of boundary adjustments pursuant to 12.3.3 or subdivisions not creating additional lots to be served by a road network which fails to meet the foregoing criteria. ii. Notwithstanding anything to the contrary in this District Plan, where any land being subdivided abuts a section of road which fails to meet the standard set out in clause a. above subdivision of that land shall be a Discretionary Activity in respect of access. <p>In addition to the objectives and policies of the District Plan and other matters to be considered pursuant to Section 104 of the RMA, an application shall be assessed in terms of the extent to which provision for access to any proposed lot is considered to have been designed so as to negate the need to upgrade a section of substandard road.</p>	<p>Compliance expected</p> <p>All proposed lots will be served by formed legal roads constructed as part of the subdivision in accordance with the relevant District Plan and Development Code requirements.</p>

Rule	Requirement	Compliance Assessment
	In any such case <i>Council</i> may decline consent to the subdivision or may impose consent conditions to avoid the potential for de facto access to any <u>lot</u> being from the section of substandard road concerned.	
12.4.4.4(b)	Access to Strategic Roads Refer to 4B.4.2.	See assessment against 4B.4.2 above.
12.4.4.4(c)	Access on to Ōmokoroa Road, Prole Road, Francis Road, Athenree Road (between State Highway 2 and Koutunui Road), Steele Road, Emerton Road (excluding the first 500m from Seaforth Road) and Waihi Beach Road (between Wilson Road and Fergus Road).	N/A
12.4.4.4(d)	Access to District roads other than b. and c. above Refer to 4B.4.3 and 4B.4.4.	See assessment against 4B.4.3 and 4B.4.4 above.
12.4.4.4(e)	<p><i>Privateways</i></p> <ul style="list-style-type: none"> i. Maximum number of <i>lots</i> served - no more than six <i>lots</i> shall be dependant on a <i>privateway</i> for legal vehicle access, provided that <i>Council</i> may allow other <i>lots</i>, up to a maximum of two, with alternative legal vehicle access to a public road but where that access is unable to comply with <i>Council's</i> minimum standards, to also have rights over a <i>privateway</i> subject to the following: <ul style="list-style-type: none"> a. Alternative legal vehicle access must be proved to be either (a) non-complying or (b) impractical to construct due to topography or other constraints or (c) would be within 30m of the <i>privateway</i> entrance boundaries using <i>Council's</i> Development Code standard drawings as a guide. 	<p>A departure is proposed to enable development density.</p> <p>The proposed subdivision is primarily served by a network of formed public roads. Where privateways are required, they have been designed to be in accordance with the District Plan, the Development Code and the further specific provisions described in the ITA report and proposed as conditions. These provisions include limits on the number of lots served and appropriate design standards. The proposal introduces additional road corridor cross sections to those described in the District Plan and Development Code to address and enable the density of development proposed. These include specified limits on lot numbers able to be served.</p>

Rule	Requirement	Compliance Assessment
	<p>b. Any such latter <i>lots</i> shall be excluded from the calculation of maximum number of <i>lots</i> served.</p> <p>iii. <i>Privateways</i> of convenience - convenience rights over an existing or proposed <i>privateway</i>, whether those rights increase the number of users above any threshold as in the rules above or not, will only be considered subject to the following:</p> <ol style="list-style-type: none"> a. It must be demonstrated that the proposed right is for occasional access only; b. If the area of land being accessed contains a <i>dwelling</i> or a <i>structure</i> supporting a commercial enterprise, then that <i>dwelling</i> or <i>structure</i> must have a separate principal, formed, complying and legal access to a public road. <p>Explanatory Note: In this instance 'principal' means that this access is the main access used most of the time.</p> <ul style="list-style-type: none"> • The occasional access right must be reflected in the wording of the easement document. • The wording of the easement document is to be agreed by <i>Council</i>. <p>iii. Public access over <i>privateways</i></p> <ol style="list-style-type: none"> a. Where proposed <i>privateways</i> will enable direct access to a public reserve, waterway, esplanade or other feature of significance and that access is not practical to construct elsewhere due to topography or other constraints, then <i>Council</i> may require public or <i>Council</i> access rights over all or part of the <i>privateway</i>. Access shall be for pedestrians only. b. This rule does not apply to existing <i>privateways</i>. c. Compensation shall be payable. <p>iv. Construction</p> <ol style="list-style-type: none"> a. Any existing or proposed <i>privateway</i> serving or over the land being subdivided shall be formed, metalled and sealed in accordance with the standards specified in <i>Council's</i> Development Code subject to the 	

Rule	Requirement	Compliance Assessment
	<p>following exceptions applying in the Rural and Lifestyle Zones.</p> <p>b. Where written statements are received from all landowners adjoining a <i>privately</i> and all those parties having an interest in the <i>privately</i> confirm that they do not require the <i>privately</i> to be constructed with a sealed surface in which case a standard metalled surface will be acceptable;</p> <p>or</p> <p>c. Where written statements are received as described above from adjacent/affected landowners and the <i>privately</i> will serve only one <i>lot</i>, or if written statements are received as described above and it is a <i>privately</i> for convenience only, then no <i>construction</i> or upgrading will be required;</p> <p>or</p> <p>d. Where the subdivision or <i>development</i> will not lead to increased usage of the <i>privately</i> in which case no upgrading will be required.</p> <p>v. In the Rural, Lifestyle, Rural-Residential, Commercial, Industrial, Residential, Medium Density Residential and Future Urban Zones the following width exceptions apply:</p> <p>a. The reserve and pavement widths required in the Development Code tables can be reduced at the point where the number of <i>lots</i> dependant on access defaults to the next (lower) standard in the tables.</p> <p>b. In the case of this occurring, the easements must be set up in such a way that the <i>lot</i> dependency is in accordance with the above.</p> <p>vi. In the Rural and Lifestyle Zones where land being subdivided fails to meet the <i>privately</i> standards in <i>Council's</i> Development Code recognition may be given to the ability of existing <i>privately</i> and accessways to extend their use to a maximum of six <i>lots</i> with a minimum 6m <i>privately</i> reserve width subject to an application for a Discretionary Activity which addresses the following criteria:</p> <p>a. Proof that the <i>privately</i> or accessway existed as at 15 June 2007;</p> <p>b. Provision of written approvals from affected parties; and</p>	

Rule	Requirement	Compliance Assessment
	<p>c. A description of the topography of the site and how this affects compliance with 12.4.4.2.</p> <p>d. The additional two lot allowance as in Rule 12.4.4.4.e.i. above shall not apply.</p> <p>vii. No <i>privateway</i> shall be created where any proposed <i>lots</i> bound an unformed road such that it negates the need to construct the unformed road to provide access to land beyond the boundaries of an existing road formed and maintained by <i>Council</i>.</p> <p>viii. Where the subdivision of an existing <i>lot</i> served by an existing <i>privateway</i> will negate or reduce the subdivision potential of any other existing <i>lot</i> served by the same <i>privateway</i> because of the resultant increase in the number of <i>lots</i> that will be dependent on the <i>privateway</i> for access, then the written approvals of the owners of any such other existing <i>lots</i> to the subdivision applied for shall be submitted with the application to <i>Council</i>. Where the foregoing circumstances apply and any necessary written approvals are not submitted, the application shall undergo limited notification.</p> <p>ix. In the Rural and Lifestyle Zones any subdivision or <i>development</i> shall have no more than one <i>privateway/road</i> as access to the subdivision/site.</p> <p>Access points should be combined into one larger standard road/<i>privateway</i> to reduce multiple conflict points and increase road safety.</p> <p>This includes proposed <i>lots</i> that would otherwise have access to a legal formed <i>Council</i> road from an existing or proposed <i>privateway</i>, unless it can be proved that it would be physically impractical to provide access to these properties from the proposed road/<i>privateway</i>.</p> <p>x. In the Rural and Lifestyle Zones for any staged <i>development</i> the access shall be formed, in accordance with Table 2, to service the final total number of proposed <i>lots</i> of all stages.</p> <p>xi. In the Rural and Lifestyle Zones where an unsealed <i>privateway</i> joins any sealed public road, or any unsealed road programmed for sealing within 10 years, the entranceway shall be formed and sealed to a point a minimum of 10m back from the edge of the road carriageway.</p>	

Classification		Minimum width – m		Max grade - %		Road function
	Road Reserve	Carriageway (includes parking bays)				
Privateway serving up to 2 units	2.7	2.5	20		Private access: max length 35m	
Privateway serving 3-6 units	5.0	3.5	12.5		Private access: max length 100m with provision for mid point passing if greater than 70m	
Roads serving up to 30 household units (with dispensation) *	12.0	6.0	12.5		Local access, connects with local roads	
Roads serving up to 30 household units	15.0	6.0	12.5		Local access, connects with local roads	
Roads serving 30 – 100 household units (with dispensation) *	15.0	8.0	12.5		Local access, connects with local roads	
Roads serving 30 – 100 household units	17.0	8.0	12.5		Local access, connects with local roads	
Roads serving 101 - 200 Household Units (with dispensation) *	17.0	8.0	10		Local access, connects with Through Road	
Roads serving 101 - 200 Household Units	20.0	8.0	10		Local access, connects with Through Road	
Road serving 201 – 300 Household units	20.0	11.0	8		Local Access. Some Through function.	
Roads serving > 300 Household units	Specific	Specific	specific		Local Access to & Through function.	
Local road in Industrial or Commercial Zone <1000 pce **	20	11	5		Local and cul-de-sac	
Industrial and commercial roads or >1000 pce **	26.0	13.0	5		Access through industrial and commercial areas	
Service lane	7.0	6.0	5		Loading of goods – no frontage	

Appendix 15: Recommended Transport Conditions Framework

Appendix 15: Recommended Transport Conditions Framework

Outline Transport Conditions Framework (subject to integration with the consolidated proposed consent conditions described in the AEE).

Note: The AEE Appendix AD: Proposed Conditions should be referred to in relation to the conditions proposed to be attached to this Fast-Track application.

GENERAL ROADING AND TRANSPORT ENGINEERING

Roading Authority Authorisation Prior to Construction

1. Provision for relevant authority authorisation to detailed engineering design plans prior to commencement of the associated work, including within the WBoPDC, NZTA, KiwiRail, and TCC authority areas.

Roading Construction

2. *THAT all roading must be constructed in accordance with the relevant Authority's Development Code.*
3. Provision for safety audit at detailed engineering and post construction engineering stage for transport infrastructure on arterial and collector road network unless otherwise agreed with the relevant local authority

Road Safety Audit (for new intersections)

4. *THAT a road safety audit must be undertaken at detailed engineering design stage for transport infrastructure on the arterial and collector road network unless otherwise agreed with the relevant local authority and must comply with Waka Kotahi's guidelines. The audit and any design adjustments (with reasons supplied) must be submitted for review at the engineering design approval process of the development.*

Street Trees/Gardens

5. *THAT street trees must be:*
 - a. *Of a genus listed in the Council's "Urban Street Tree and Planting Guide" dated November 2021 and approved by the Council, in conjunction with the other engineering plans for this application*
 - b. *Planted as per the aforementioned engineering design.*

Streetlights

6. *THAT street lighting must be provided as per AS/NZS 1158 2005 Road Lighting, as modified by NZTA specification M30 (LED luminaires) and Auckland Transport's approved Streetlight List. The design must be certified to comply with the above requirements by a Chartered Professional Engineer. Confirmation is also required from the power supply authority that the streetlights are operational.*

New Vehicle Entrance

7. *THAT a vehicle entrance to serve any proposed Lot/private way / proposed dwelling be constructed to comply with the Council's Development Code.*

Upgrade Existing Vehicle Entrance

8. *THAT any existing vehicle entrance serving a proposed Lot/private way / proposed dwelling be upgraded to comply with the Council's Development Code.*

Remove Redundant Vehicle Entrance

9. *THAT any redundant vehicle entrance(s) must be removed, and the berm features reinstated.*

Line of Sight Maintenance

10. *THAT all vegetation located within the road reserve must be trimmed to provide and maintain complying sight distance(s) from vehicle entrance(s) to comply with the Council's Development Code at the consent holder's expense.*

New Private Way

11. *THAT any proposed private way be constructed to comply with the Council's Development Code.*

Upgrade Existing Private Way

12. *THAT the existing private way be upgraded as required to comply with the Council's Development Code.*

Vehicle Crossing Application (for simple subdivision development)

13. *THAT before any works commence on a site / Lot requiring a vehicle crossing, a vehicle crossing application must be submitted to the council for review and approval. This application must be required for any new vehicle crossings to the roading network or upgrade of an existing vehicle crossing. Click [here](#) for more information on the service connection process and to download the application form(s).*

Privateway Maintenance

14. *THAT a consent notice must be registered on the Record of Title for Lot(s) serviced by a privateway, such that in accordance with the easement arrangements, the property owners' maintenance obligation extends to the entire formation of the portion of the private way they have an interest in including, but not limited to; original ground built upon, earthworks, cuts and fills, pavement, sealed surface, culverts, drainage structures, plantings and any other structures or features serving the private way. The costs must be shared evenly with any other property owners having an interest in that portion of the private way. Under no circumstances must Council take any responsibility for the maintenance and upkeep of the private way formation.*

Fencing Costs

15. *THAT a consent notice pursuant to section 221 of the Resource Management Act 1991, must be issued against the Titles of any Lots that share a common boundary with any of the following local purpose reserves.
 - a. Accessway
 - b. Stormwater
 - c. Wastewater
 - d. Recreation*

The consent notice must advise the owners and subsequent owners thereof, of the requirements to meet the full cost of any fencing along the common boundary between the lot and adjoining land that is intended to be vested to Council as a local purpose reserve.

Note: Upon application for the s223 certificate for the subdivision, the consent holder must confirm in writing to Council which lots require a fencing consent notice to be registered on its title.

EASEMENTS

Easements Over Public Mains

16. *THAT easements (in gross) must be created over any public infrastructure within private lots, private ways, or reserve land in favour of the Council as a dominant tenement, and this is shown on the survey plan.*

Private Drainage/ROW Easements

17. *THAT all easements required for services and rights of way serving the allotments within the subdivision area must be duly granted or reserved. Easements relating to wastewater, stormwater, and water must be endorsed on the lodged survey plan in a Memorandum of Easement pursuant to Section 223 of the Resource Management Act 1991.*

VESTING

Road Vesting

18. *THAT any proposed Lots to be vested as road shall be engaged with the relevant Road Controlling Authority(s), agreed in advance and vested.*

Vesting Local Purpose Reserves

19. *THAT any proposed Lot(s) to be vested as local purpose reserve (Drainage/Accessway/Recreation) shall be engaged with the relevant Authority(s), agreed in advance and vested.*

AS-BUILT INFORMATION

Benchmarks

20. *THAT benchmarks are installed, and the locations/levels fixed by survey in accordance with Council's Development Code and as-built data requirements. Numbered bronze markers can be obtained without charge from Council's Land Development Engineering Team.*

As-Built

21. *THAT as-built information and drawings must be provided (in NZVD16 Datum) for all vested assets, service connections, and earthworks (extent of cut and fill) in accordance with the Council's Development Code.*

Final Contour Plan

22. *THAT a final contour plan in NZVD16 Datum must be provided in accordance with Council's Development Code.*

CERTIFICATION

Quality Assurance

23. *THAT the consent holder's representative must submit to the Chief Executive Officer or duly Authorised Officer, all quality assurance and testing records that are required in accordance with Council's Development Code, including sealing records.*

MAINTENANCE BOND

Maintenance Bond

24. THAT a 5 percent maintenance bond (or [REDACTED] whichever is greater) calculated from the approved asset schedule (Cert 1c) must be paid in respect to the additional Council assets created by this subdivision, in accordance with the requirements of the Council's Development Code, or as otherwise agreed between the parties.

Maintenance Period

25. THAT at the end of the maintenance period (defined as a maximum of 12 months or as otherwise agreed between the parties), all maintenance items are required to be certified as complete including that the berms have been mown, carriageways and footpath swept and catch-pits cleaned by the subdivider's representative.

ADVICE NOTES

CAR & WON

26. The consent holder is advised that an approved "Corridor Access Request" is required to construct a vehicle crossing and utilities connections. The application can be made through Council's online service submitica.
27. The consent holder is advised that an approved "Working on Utilities Notice" is required to connect to Council's live utilities assets. The application form may be obtained from Council's Customer Service Department.

RAPID Numbers

28. You are reminded of the requirements of rural delivery, comms and power utility, and emergency service providers for clear identification of rural properties. The Council website contains more information, and an Application Form should you wish to apply for a RAPID number plate.

Road / Privateway Naming

29. Road naming (including privateways with six or more lots) – the consent holder is advised to apply for these at Engineering Design Approval stage or, at least three months prior to lodging 224 application as the road naming process can take time to complete the approval process. Council's road naming policy sets out the approach and process for the application and can be found by clicking the following hyperlink – [Road Naming Policies](#). Please submit your application via the online portal (Post-decision

application – Road or Street naming) and email the Consents Administration team

30. *[Roads to Vest - Community Board recommendation and Final decision from Western Bay of Plenty Delegated Authority. Private Ways – Final decision is made by Delegated Authority at Western Bay of Plenty].*

TRANSPORT INFRASTRUCTURE DESIGN AND STAGING

Confirmation of Extent of the Works

31. Prior to commencement of any stage of development that triggers a requirement for transport mitigation under these conditions, the Consent Holder shall engage with the relevant Road Controlling Authority (or Authorities) to confirm the nature, scope, extent or alternate transport mitigation works required to satisfy these conditions, unless otherwise agreed in writing by the relevant authority.

Alternate Design Solutions

32. Alternative design solutions, transport layouts, construction methodologies and/or staging approaches may be proposed by the Consent Holder provided that they achieve the same or better transport outcomes, are supported by appropriate technical assessments, and are approved in writing by the relevant Road Controlling Authority prior to implementation.

Road Corridor Future-Proofing

33. All identified secondary arterial road corridors within the Wairakei South area shall be established to a minimum corridor width of at least 36.0 meters, unless otherwise agreed in writing by the relevant Road Controlling Authority.
34. The internal road network shall be designed, formed and staged so as to maintain the ability to extend the secondary arterial road network to the southern boundary of the site to enable a future potential connection to Seddon Street (or an alternative connection) to the Te Puke Township, including the future Te Puke Spatial Plan area.

Safe Intersection and Driveway Sight Distance

35. Safe sight distances at intersections, accessways and vehicle crossings shall be established in accordance with Austroads Guide to Road Design Part 4A: Unsignalised

and Signalised Intersections, 3. Sight Distance unless otherwise approved by the relevant Road Controlling Authority.

36. Where a departure from the Austroads sight distance criteria is proposed the Consent Holder shall prepare a site-specific safety assessment, subject to written approval by the relevant authority prior to construction that:
- a. identifies the nature and justification for the departure;
 - b. assesses the operational and safety effects; and
 - c. proposes localised mitigation measures to ensure safe operation.

On-street Visitor Parking

37. On-street parking within the residential zoned local street network shall be provided at a rate of at least 1 visitor parking space for every 7 residential dwellings.

Bus Priority Measures

38. Where traffic signal infrastructure is constructed or upgraded as part of the approved development, provision shall be made for the incorporation of bus priority measures within the signal system, unless otherwise specified or required by Bay of Plenty Regional Council or the applicable Road Controlling Authority at the time of implementation.

Transport Network Capacity Assurance and Growth Accountability

39. The internal Wairakei South transport network shall be staged to align with integrated land use outcomes and external transport network capacity, as defined by the staged infrastructure thresholds set out in Condition 48;
40. At each staging threshold identified in Conditions 48 (or as otherwise agreed), the Consent Holder shall prepare and submit a **Transport Network Accountability Report** subject to the relevant Consent Authority authorisation, that includes the following:
- a. A **Development Staging Plan** showing the total number of dwellings, the net development area of Industrial (ha), the trips allocated to those areas and the cumulative trip total for the:
 - i. Existing formed activities; and
 - ii. Committed, consented but not yet developed activity; and
 - iii. Proposed development activity the subject of the application, and

- b. An assessment correlating the level of development with the transport mitigation required by these conditions;
 - c. Confirmation of the compatibility of development rates with land-use assumptions adopted in the transport modelling for The Sands Town Centre, Te Tumu and Wairakei South;
 - d. Five-day average daily traffic volumes (both directions) on the Tauranga Eastern Link between the Papamoa East Interchange on- and off-ramps;
 - e. An assessment of any exceedance of modelling assumptions or infrastructure capacity attributable to the development; and
 - f. Where an exceedance is identified, recommended remedies, timing, and responsibilities.
41. Where an exceedance is identified and wholly attributable to the Wairakei South development, the Consent Holder shall, within 30 working days of lodgement of the **Transport Network Accountability Report**, engage with the Consent Authority and relevant Road Controlling Authority to agree the nature and timing of remedial works.;

Advice Note:

*The purpose of the **Development Staging Plan** is to demonstrate compliance with the staged infrastructure threshold conditions and to monitor the rate of development and the potential effects of that development on the transport network in terms of the transport modelling assumptions for growth and total staged demand adopted in the transport modelling assessments.*

Traffic counting on the TEL at the PEI as described will inform the extent to which other external region-wide traffic growth is occurring and potentially impacting the modelling assumptions.

Private Developer Agreement

42. Where transport infrastructure required by these conditions is to be delivered by way of a Private Developer Agreement (PDA), the Consent Holder shall enter into a PDA with the relevant authority prior to construction, setting out funding, delivery responsibilities, timing, standards and other such matters as agreed between the parties

Construction Traffic Management Plan

43. Prior to the commencement of any construction works, the Consent Holder shall submit a **Construction Traffic Management Plan** (CTMP) to the relevant Road Controlling Authority for certification.

44. The **CTMP** shall include the following:
- a. identify construction access locations and access layouts;
 - b. site office, amenities and on-site parking areas;
 - c. confirm haul routes, including any restrictions on routes, times or vehicle types;
 - d. manage the timing and frequency of heavy vehicle movements;
 - e. provide for appropriate temporary traffic management measures in accordance with the New Zealand Guide to Temporary Traffic Management (NZGTTM);
 - f. provisions for the avoidance of detritus tracking on public roads and measures to respond and address this in the event it occurs;
 - g. address the safety of all road users, including pedestrians and cyclists where relevant;
 - h. ensure continued access for adjacent landowners, businesses and emergency services;
 - i. include communication, stakeholder liaison and complaints management procedures;
 - j. include provisions for transport of over-size vehicles and associated permits; and
 - k. Where construction activities interact directly with the public road network, site-specific TMPs may be prepared and implemented in accordance with the approved CTMP and submitted to the relevant RCA for certification prior to works commencing.

45. Where heavy commercial vehicle movements using the Bell Road corridor are proposed, a **Pavement Impact Assessment** (PIA) shall be prepared by a suitably qualified pavement engineer.

46. The **PIA** shall include the following:
- a. The purpose of the assessment;
 - b. Methodology and scope;
 - c. Current and forecast traffic load calculations;
 - d. Council held RAMM Database information including:
 - i. Traffic counts;
 - ii. Carriageway pavement and surfacing type and age;
 - iii. Condition survey data;
 - iv. Pavement testing data;
 - v. Surface testing data;
 - e. Further pavement testing undertaken;

- f. Pavement modelling and impact assessment due to the proposal; and
- g. Pavement improvement design and timing recommendations.

Subdivision Roding Cross Sections

47. Road carriageway cross sections to be in general accordance with the following cross-sectional form:

Classification	Road Reserve Width (m)	Carriageway Width including Parking (m)	Public / Private	Max Grade (%)	Units Served (Inclusive)	Indicative Speed Limit (km/h)	Principal Function
Secondary Arterial	36	23.4	Public	10	Any	Up to 60	Through movement, limited access
Collector Road (Industrial)	25	16	Public	10	Any	Up to 50	Connectivity between local and secondary arterial and property access
Collector Road (Residential)	25	14.5	Public	10	Any	Up to 50	
Collector Road - Bell Road West (Mid-block)	25	10	Public	10	Any	Up to 60	Rural cross section transport network distribution, no direct access
Collector Road - Bell Road Central (Mid-block)	25	11.5	Public	10	Any	Up to 60	
Collector Road - Bell Road East (Mid-block)	25	12	Public	10	Any	Up to 60	
Industrial Reserve Edge	20	15.5	Public	10	Any	40	Local transport network distribution and accessibility
Primary Residential	20	12	Public	10	Any	40	Local access, some minor through function
Secondary Residential	18	10.1	Public	10	<300	40	Primary residential access
Local Residential	12	7.7	Public	12	<50	40	Local access
Access Lane	9	5.5	Private	20	<20	10	Shared street, multi-modal

48. Road carriageway cross section variations may be considered by way of a departure application and subject to authorisation by the relevant Authority

Staging Off-Site Transport Infrastructure

49. Up to 2,750 dwellings and 55ha net developable site are of Industrial shall be enabled, subject to:

- a. In relation to off-site transport infrastructure where access is solely reliant on the Bell Road corridor for access, up to **500** dwellings shall be enabled subject to the following mitigation prior to occupancy of any dwelling
 - i. Preparation of a **Transport Network Accountability Report** in accordance with **Condition 39**
 - ii. Bell Road / Parton Road intersection upgrade and right turn bay on Bell Road

- b. In relation to off-site transport infrastructure where access is solely reliant on the Papamoa East Interchange (PEI) for access, up to **1,127** dwellings and **5ha** net developable site area of Industrial shall be enabled subject to the following mitigation prior to occupancy of any dwelling:
 - i. Preparation of a **Transport Network Accountability Report** in accordance with **Condition 39**

- ii. Resolution of land parcel ownership and access across the Tauranga Eastern Link (TEL) spine strip to enable access between Wairakei South and the PEI interchange prior to transport movement across it
 - iii. A westbound off-ramp left turn lane to Wairakei South prior to enabling development within the site, reliant on access via the PEI
 - iv. An eastbound off-ramp right turn lane length extension to Wairakei South prior to enabling development within the site, reliant on access via the PEI
 - v. Establishment of a signalised intersection at the PEI southern intersection incorporating the westbound off-ramp, westbound on-ramp and a new signalised link accessing Wairakei South to the south
- c. In relation to off-site transport infrastructure where access is enabled via both the PEI and Bell Road corridors, up to **1,400** dwellings and **8ha** net developable site area of Industrial shall be enabled subject to the following mitigation prior to occupancy of any dwelling:
- i. In addition to the works described in **Condition a, and b**, the following:
 - ii. Preparation of a **Transport Network Accountability Report** in accordance with **Condition 40**
 - iii. A Bell Road corridor/carrageway widening in accordance with the Plans (Maven) Circa a 12m road cross section comprising 2 by 3.5m wide traffic lanes, 1.5m wide sealed road shoulders each side, 1.0m wide unsealed shoulder edges and road safety guard railing where identified as necessary against the adjacent drainage channels and electrical infrastructure
 - iv. Bell Road / Te Puke Highway speed zone reduction and intersection traffic signalised intersection, or alternative by agreement with the relevant authority where the speed zone is not able to be authorised
 - v. Bell Road Rail Crossing safety and capacity improvement works as follows:
 1. Prior to commencement of detailed engineering design, engagement with KiwiRail and WBoPDC on the form of mitigation, design development and authorisation processes
 2. Development of detailed engineering design for construction subject to authorisation by KiwiRail and WBoPDC
 3. Design development to be in accordance with the NZ Transport Agency Traffic Control, Devices Manual Part 9: Level Crossings:

- a. Figure A8 Multilane road with FLB and HAB active control;
 - b. Figure A9.2: Intersection close to level crossing – distance (D) 10-30m; and
 - c. Figure A13: Emergency escape zone
 4. Design to be in accordance with the Vitruvius prepared Bell Road Level Crossing Safety Impact Assessment (February 2026), subject to detailed engineering design authorisation
- d. In relation to off-site transport infrastructure mitigation supporting up to the cumulative total of **1,734** dwellings and **8ha** net developable industrial land (2035 modelled land use assumptions), where access is enabled via both the PEI and Bell Road corridors:
- i. In addition to the works described in **Conditions a, b and c**, the following:
 - ii. Preparation of a **Transport Network Accountability Report** in accordance with **Condition 40**
- e. In relation to off-site transport infrastructure mitigation supporting up to the cumulative total of **2,500** dwellings and **49ha** net developable industrial land (2048 modelled land use assumptions)
- i. In addition to the works described in **Conditions a, b, c, and d**, the following:
 - ii. Preparation of a **Transport Network Accountability Report** in accordance with **Condition 40**
 - iii. Domain Road interchange, northbound TEL on-ramp capacity improvements, extend the on-ramp merge length by 50m subsequent to exceedance of the 2035 modelled land use assumptions
 - iv. An additional southbound lane on Sands Ave between Te Okuroa Drive and the southern side of the PEI interchange including the pedestrian / cycle bridge
 - v. An additional northbound right turn lane on Sands Ave for the full length of the corridor between Te Okuroa Drive and the northern PEI intersection

- f. In relation to off-site transport infrastructure mitigation supporting up to the cumulative total of **2,750** dwellings and **55ha** net developable industrial land (2063 modelled land use assumptions)
- i. In addition to the works described in **Conditions a, b, c, d and e**, the following:
 - ii. Preparation of a **Transport Network Accountability Report** in accordance with **Condition 40**
 - iii. An eastbound PEI bypass lane between the eastbound off-ramp and Te Tumu employment area or formation of the Bell Road Link east to the Te Tumu employment area, including resolution of any lwi or other third-party access corridor
 - iv. Upgrading of the Te Okuroa Drive / Sands Ave signalised intersection phasing software to enable a double diamond phasing arrangement to support intersection phasing optimisation
 - v. Connection of Latham Drive between Sands Ave / Bill Miller Drive intersection and the Te Tumu western boundary Collector Road (or other alternate and equivalent transport distribution corridor) that enables traffic distribution to/from Te Okuroa Drive and The Boulevard. Where this necessitates formation of the Te Tumu western boundary Collector Road between either or both of Te Okuroa Drive and The Boulevard, this work shall be undertaken subject to lwi or other third-party access resolution
 - vi. An additional 60m southbound lane on the northern approach to the Te Okuroa Drive intersection
 - vii. Formation of free left turn lanes on the Sands Ave southern approach to The Boulevard and on The Boulevard eastern approach to Sands Ave